

QA
95
L16

B.3.8

**NON
CIRCULATING**

a

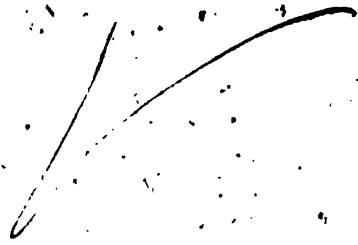



Pleasure with Profit:

Consisting of

RECREATIONS

OF

DIVERS KINDS,

VIZ.

<i>Numerical,</i>	<i>Astronomical,</i>	<i>Automatical,</i>
<i>Geometrical,</i>	<i>Horometrical,</i>	<i>Chymical,</i>
<i>Mechanical,</i>	<i>Cryptographical,</i>	and
<i>Statical,</i>	<i>Magnetical,</i>	<i>Historical.</i>

Published to Recreate Ingenious Spirits; and to induce them to make farther scrutiny into these (and the like) **SUBLIME SCIENCES.**

AND

To divert them from following such Vices, to which Youth (in this Age) are so much Inclind.

By **WILLIAM LEYBOURN**, Philomathes.

To this Work is also Annex,

A TREATISE OF ALGEBRA,

According to the late Improvements, applied to *Numerical Questions* and *Geometry*; with a **NEW SERIES** for the speedy *Extraction of Roots*; as also a **CONVERGING SERIES** for all manner of *adfected Equations*.

By **R. SAULT**, Master of the *Mathematick School* in *Adam's Court*, in *Broadstreet*, near the *Royal Exchange*, **LONDON.**

LONDON:

Printed for **Richard Baldwin**, and **John Dunton**; near the *Oxford-Arms* in *Warwick-Lane*: And at the *Raven* in the *Poultry*. 1694.



Handwritten notes:
A list of
names
17-1-34
29283

I

To the **INGENIOUS** **READERS:**

And principally

To such as are **MATHEMATICALLY** Inclined.



RECREATION, (saith a late Learned Divine) is a second **CREATION**, when *Weariness* hath almost annihilated our *Spirits*: It is the *breathing* of the *Soul*, which would otherwise be *stified* with continual *Business*.

And this Interval of *Rest* or *Recreation* produceth the same *Effect*, as well in *Sensitives* and *Vegitives*, as it doth in *Man*: According to that of the *Scholias*t.

Ager Veritanus, &c.

A *Field* left *Fallow* some few years, will yield
The *Richer Crop*, when it again is *Till'd*:

A *River* stopped by a *Sluice* a space,
Runs after *rougher*, and a *swifter pace*:

A *Bow* a-while *unbent*, will after cast
Its *Sbafts* the *farther*; and them *fix* more *fast*:

A *Soldier* that a season still hath lain,
Comes with more *fury* to the *Field* again.

Even so *Man's Body*, while to gather *Breath*,
From *Rest*, to *Pain* again, it sojourneth;
It re-collects its *Poars*, and with *Cheer*
Falls fresh again into its first *Carreer*.

In the Choice of our *Recreations*, we ought to be well satisfied, (1.) In the *Lawfulness* of them. (2.) That they be *Ingenious*: And (3.) That they bear proportion with the *Age*, *Sex* and *Constitution* of *Body* of the *Party* using them: For,

9-12-34. H.A.

As *Recreations* and *Exercises* (whether of *Body* or *Mind*) are *various*: So one *Dish* of *Meat* may as well please all *Palates*; as one *Recreation* suit all *Dispositions*: And (as I have said elsewhere upon the like occasion), That, although some *Corporeal Exercises* may to some *Bodies* tend more to *Health*, and some *Mental Labours* more to *Wealth*; yet none affords the *Mind* more pleasure with less repentance, than those of the *Mathematicks* do.

For instance in a few *Corporeal Exercises*; with Reflections upon some of them.

Ringing,] It oft-times makes good *musick* on the *Bells*; but (being a violent and boisterous *Exercise*) puts Mens *Bodies* out of *tune*: So that by over-heating of themselves, they have rung their own *Passing-bell*.

Fishing with the *Angle*,] (an *Exercise* with which *Dr. Whitaker* was much delighted) is a *Recreation* relishing best with some; but to other *Dispositions* most *distasteful*; and rather a *torture* than a *pleasure*; to stand an whole hour, or more, as *mute* as the *Fish* they hope to take.

Hunting] is an *Exercise* most *delightful*, and much in request both with the *Nobility* and *Gentry* of this *Land*; yet *William Cecill*, sometime *Lord Treasurer* of *England*, took no pleasure in it: For, when some *Noble-men* had gotten him to ride with them a *Hunting*, and the *Sport* began to be *cold*; What call you this, says *My Lord*? Oh! Now, said they, *The Dogs are at a fault*. Yea, quoth the *Treasurer*, take me again in such a *Fault*, and I'll give you leave to punish me for't.

Cornelius Agrippa terms it a most detestable *Recreation*, and vain *Exercise*; a *Pastime* cruel, and totally *Tragical*: And from the beginning (says he) was the *Exercise* of the worst of men; for *Cain*, *Lamech*, *Nimrod*, *Ishmael* and *Esau*, were mighty *Hunters*: But in the *New Testament* we read not of any one that was given thereunto: Yet *Nicholaus* the *Third*, a *Roman*, and *Pope* of *Rome*, was so extremely delighted in *Hunting*, that he inclosed a *Warren* of *Hares* on purpose for his *Holiness's Recreation*.

Fowling,] *Ulysses* is said to be the first *Inventer* thereof; who after the taking of *Troy*, was the first that brought into *Greece* *Birds* of *Prey* manur'd for *Game*; to comfort with *New Recreations* those that had lost their *Parents* and *Acquaintance* in the

the

the *Trojan War*: And yet he commanded his Son not to make any use thereof. Notwithstanding this and the foregoing *Exercises* (tho mean and servile in themselves) are now come to be so far esteemed, that the Nobility and Gentry, forsaking other Liberal and Noble Sciences, make these their chief Learning. Mr. *Barton* in his *Melancholy*, tells a Merry Story out of *Poggius the Florentine*, condemning the folly of those *Fowlers*; which is this. "A *Physician* of *Millain* (saith he) that "cured *Madmen* and *Idiots*, had a *Pit* of *Water* in his *House*, "in which he kept his *Patients*; some up to the *Knees*, some "to the *Girdle*, and some to the *Chin*, *pro modo insanie*, as they "were more or less affected. One of his *Patients*, which was "pretty well recovered, standing at the *Physicians Gate*, and "seeing a *Gallant* ride by with a *Hawk* on his *Fist*, with his "Spaniels after him, would needs know to what use all this "preparation served? the *Gallant* made answer, To kill *Partridges* and other *Fowl*. The *Patient* demanded again, What "his *Fowl* might be worth which he killed in a year; he "reply'd, *Five or Ten Crowns*: And when he urged him further, What his *Hawk*, *Horse* and *Dogs* stood him in? he "told him *Four hundred Crowns*: With that, The *Patient* bad "him be gone, as he tendred his *Life* and *Safety*: For (said "he) if our *Master* should come and hear you say so, he "would put you into his *Pit* up to the very *Chin*.

Shooting with the Long Bow] is a *Noble Recreation*, and an half *Liberal Art*: There is hardly any comparable to it, for stirring every part of the *Body*: It openeth the *Breast* and *Pipes*; exerciseth the *Arms* and *Feet* with less violence than *Running*, *Leaping*, and the like. And herein was *Domitian* the *Emperor* so cunning, that it is reported of him, That let a *Boy* a good distance off hold up his *Hand* against a *Wall*, and stretch his *Fingers* abroad, he would shoot through the *spaces* without touching the *Boys Hand*, or any *Finger* of it. And it is reported of *Domitian* the *Emperor*, That at two shoots he should fix his *Shafts* in the *Front* of *Wild Beasts* like a *Pair* of *Horns*. King *Edward* the *Sixth* of *England*, with the *Long Bow* (though he drew no *Strong* one) shot very well: And once, when *John Dudley*, *Duke* of *Northumberland*, commended him for hitting the *Mark*: You shot better (quoth the *King*) when you shot off my *Good Uncle Protector's Head*.

Running, *Leaping*, *Dancing* and *Walking*,] are all *Excellent Recreations*, used in the *Morning*; as we read *Alexander* and

Epimanondas did. King *Henry* the Fifth of *England* was so swift in running, that he, with two of his Nobles (without Bow, or other Engine) would take a *Wild Buck* or *Doe* in a large *Park*. Also *Harold*, the Son of *Canutus* the Second, was surnamed *Harefoot* for his swift running. And *Ethus*, King of *Scotland*, was of that swiftness, that he almost reached that of *Stags* or *Grayhounds*; and was therefore called *Alipes*, or *Wing'd-foot*. *Philippides* an *Athenian*, in the space of two days, did run 150 *Roman Miles*. And one *Euclides*, another of the same Countrey, went and returned in one day 125 of the like *Miles*.

But those are the best Exercises, which (besides the refreshing of the Body) enable men to some other good Ends: As

Bowling,] It teaches Mens Hands and Eyes *Mathematical Proportion*: — And (for a Home-Diversion) the Play at the *Billiard Table* hath not its Peer: It exercises the whole Body moderately; the strength of the Arm judiciously: It directs the Hand Geometrically, and the Eye Optically: For the attaining to be an Exquisite Proficient in playing at it, depends wholly upon putting in practice that *Axiome* of *Euclid* in his *Catoptignes*; which demonstrates, that, *The Angles of Incidence and Reflection are ever more equal*.

Swimming] hath saved many a man's Life, when himself hath been both the *Ship* and the *Cargozoon*. And single Persons, by their dexterity in this Art, have not saved their own Lives only, but their Countrey also. For (as *Livie* relates) One *Horatius Cocles*, That, after a long time, he alone, had defended the Bridge over *Tyber* against the *Hetruscans*, the *Romans* brake it down behind him; wherewith, in his *Armour*, he cast himself into the *River*, and (notwithstanding a shower of *Darts* and *Arrows* were sent after him) swam with safety into the *City*; which rewarded him with a *Statue* erected in the *Market-place*, and as much *Land* as he could encompass with a *Plough* in one day. — And as resolute an Attempt was that of *Gerrard* and *Harvey*, two Gentlemen of our own Nation, who in the Fight at Sea in 1588. swam in the Night-time, and pierced with *Augres*, or such like Instruments, the sides of the *Spanish Gallions*, and returned back safe to the *English Fleet*. And *Vincent* in his Travails reports, That at *Barlavento*, *Calo* and *Hispaniola*, he hath seen men stay under water the space of three quarters of an Hour; and hath heard of those that would continue an whole Hour.

The forementioned Exercises are such as are generally used,
and

To the READER.

V

and do tend to the health of Mens Bodies ; and for the prevention of several *Maladies* to which by Nature they are inclin'd. But there are other *Corporeal Exercises* which are more *Heroical*, and fit only for the *Recreation* of *Princes*, and such *Noble Heroes*, whose principal Ambitions tend to the defence of their *King* and *Countrey* : And such are, *Horsemanship*, *Tilting*, *Tournamenting*, *Throwing the Bar*, *Wrestling*, &c. Of which instances might be given of many *Emperors*, *Kings* and *Generals*, who have performed great *Exploits* thereby. But leaving those of the *Body*, I shall proceed to such *Recreations* as adorn the *Mind* ; of which those of the *Mathematicks* are inferior to none.

Now the *Excellency* of any *Science* (says the *Philosopher*) may be judged of, (1.) By the *Excellency* of the *Object* : And (2.) by the *Certainty* of its *Demonstrations*:

First, For the *Object* ; It is no less than the *whole World* : Not only of the *Terrestrial*, but the *Cæstial* part thereof also. So that in this respect it far exceeds all those empty and barren *Speculations* about *Materia Prima*, or *Universale* : In the Study of which so many do mispend their *Younger Years*.

Secondly, For the *Demonstrations* of these *Sciences*, they are as infallible as *Truth* it self : And for this reason also doth it exceed all other *Knowledge* which depend upon *Conjectures* and *Uncertainty*. Since therefore in these respects, it is one of the most *Excellent Sciences* in *Nature*, it may best become the *Industry* of *Man*, who is one of the best *Works* of *Nature*. And for that end was he made with an *Elevated Aspect*, with *Head* and *Eyes* exalted : And for what reason, the *Poet* tells you,

*Os Homini sublime dedit, Celumque tueri
Jussit, & erectos ad Sydera tollere vultus.*

God gave to Man an upright Face, that He
Might view the Stars, and learn *Astronomy*.

And thus the *Kingly Prophet David*, *Psal.* 8. v. 3, 4. falls out into this *Admiration*, *When I consider the Heavens, the Works of thy Fingers ; the Moon and the Stars which thou hast created ; What is Man, that thou art mindful of him, and the Son of Man that thou visitest him !* Upon which Text, *Sandys* thus excellently *Paraphrases*.

When I pure Heaven, thy *Fabrick* see ;
The Moon and Stars, create by Thee

O !

O! what is Man, and his frail Race;
That Thou should'st such a shadow grace!

Now these *Sciences* being so excellent in themselves, and of such benefit to us, we cannot spend our leisure hours better, than in these Sublime *Sciences*. It was so with *Julius Caesar*, who amongst the Broils and Tumults of the Camp, made choice of this for his *Recreation*: As *Lucan* says of him, *Lib. 10.*

——— *Media inter prelia semper
Stellarum, Cœlique plagis, superisque vacavit.*

He always leisure found amidst his Wars,
To mark the course of Heaven, and learn the Stars.

And for this reason likewise did *Seneca*, amidst the continual Noise and Bustle of the *Court*, betake himself to this *Recreation*.

O quam juvabat, &c.

O what a Pleasure was it to Survey
Natures Chief Work, the *Heavens*! Where we may
View the alternate *Courses* of the *Sun*,
The Sacred *Chariots*, how the *World* does run:
The *Moon's* bright *Orb*, when she's attended by
Those scattered *Stars*, whose *Light* adorns the *Sky*.

And thus let what I have already said concerning the *Excellency*, *Utility* and *Benefit* of these *Mathematical Arts* suffice. It may be expected I should say something concerning those which I have selected in the following *Treatises*: But for that I refer you only to the *Table of Contents* following: And for the *using* of them, make them as *Ballast* to a *Ship*; to *fix* it, not to *stall* it; so as to juggle out its other *Cargo* of *less weight*, though of *greater importance* to *Mundane subsistence*. But I will deter thee (*Reader*) no longer in the *Porch*, but invite thee into the *Inner Rooms*; into which *Ingrede ut Proficias*: And so, for this time,

Farewell.

The

The TABLE of CONTENTS, and Order of the Whole BOOK.

TRACT. I. Numerical Recreations.		<i>Cochlea: Of the Wheel.</i>	5
		<i>Vectis: Of the Leaver.</i>	7
O F Digit, Article, Mixt, Square and Cube Numbers, and some Observa- tions upon them. Pag. 1		<i>Of Archimedes his Water-Screw.</i>	9
<i>Of Comparative Arithmetick, or of the Relation of Numbers in Quantity.</i>	12	<i>From whence a Perpetual Motion attempted.</i>	10
<i>Of Arithmetical, Geometrical and Musical Pro- portions.</i>	14	<i>A Mechanical Paradox.</i>	12
<i>Numerical Theorems.</i>	17	<i>Of other Engines for the moving of Heavy Bodies; and other for Violent Motions.</i>	14
<i>Concerning the Golden Rule, both Simple and Compound.</i>	21	<i>Of Engines of War.</i>	15
<i>Of the Increase of Swine, Corn, Sheep, &c.</i>	23	<i>Of Automata: Or Self-Movers.</i>	16
<i>Of Changes in Bells, Musical Instruments, Voices, &c.</i>	29	<i>Of divers Magnificent Works of the Ancients.</i>	20
<i>Of Numerical Verifying.</i>	32	<i>The height of several Obelisks, Steeples, Pyramids and Pillars in the World, according to our Eng- lish Measure.</i>	23
<i>Of Numbers thought upon.</i>	41	<i>Of some such admirable Pieces of Work of several kinds, as have been made by Artists both Ancient and Modern.</i>	24
<i>Numerical Enigmatical Problems.</i>	33	TRACT. IV. Statical Recreations.	
<i>Of Extracting the Square Root of any Number, without Multiplication or Division.</i>	46	O F the Art Statical. Pag. 1	
<i>A most Compendious way of Multiplication.</i>	50	<i>Concerning the Ballance.</i>	ibid.
<i>Of the Rule of Ceres and Virginum.</i>	51	<i>Statical Theorems.</i>	3
<i>Numerical Devices.</i>	55	<i>Of the Ballance of Signeur Galileo Galilei.</i>	5
TRACT. II. Geometrical Recreations.		<i>Six Statical Theorems of Archimedes, taken from his Treatise, De Incidentibus Aqua.</i>	8
O F Geometrical Definitions, and Practical Problems. Pag. 1		<i>The Comparison of several Metals in Quantity and Weight.</i>	10
<i>How (without Compasses) having only a common Fork, and a Plain Rule, to perform many plea- sant Geometrical Conclusions.</i>	16	<i>Of the Roman and English Foot.</i>	11
<i>Geometrical Arithmetick in all its Rules.</i>	28	<i>The Ancient Roman Weights, and our English, compared.</i>	12
<i>Mechanical ways of measuring of Heights, Depths and Distances.</i>	39	<i>The weight of Spheres of several Metals compared.</i>	13
<i>Of Altimetria; or of the Mensuration of Heights Accessible or Inaccessible.</i>	39	<i>Of the worth, weight, magnitude, &c. of several Metals and Liquors.</i>	14
<i>Of Longimetria: Or of the Mensuration of Di- stances, Accessible or Inaccessible.</i>	41	<i>Of the weight of Water and other things, in weight and magnitude compared.</i>	15
<i>Of Planometria: Or of the measuring of Land Mechanically.</i>	44	<i>A Comparative Table of the weight of Metals, Grains, Liquors, &c.</i>	17
<i>How to lay down, or make a Plot of any piece of Ground measured as aforesaid; and to find the Quantity thereof in Acres, Roods and Perches.</i>	51	<i>Foreign Weights and Measures compared with the English.</i>	18
<i>Of the taking of Heights, Depths and Distances, accessible or inaccessible; As also of the Survey- ing of Land more artificially by Graduated In- struments.</i>	52	<i>Statical Experiments.</i>	20
<i>To make a Plot, and to cast up the content thereof.</i>	66	<i>A Postscript.</i>	23
TRACT. III. Mechanical Recreations.		TRACT. V. Astronomical Recreations.	
O F Engines, by help of which very Great Weights may be raised with small strength. Pag. 1		A Brief View of Astronomy. Pag. 1.	
<i>Proclea: Of the Pulley.</i>	2	<i>Of a Material Sphere, the Circles thereof, and the Use and Offices of them.</i>	2
<i>Of the Inclining Plain.</i>	3	<i>Of the Two Principal Systems of the World, Pto- lomean and Copernican.</i>	6
<i>Cuneus: Of the Wedge.</i>	4	<i>The Ptolomean System argued for, and maintained, and the Copernican Arguments against it an- swered.</i>	8
<i>Of the Crane, Capstern, or Wheel.</i>	ibid.	<i>The Strongest Arguments (by way of Objection) the Maintainers of the Ptolomean System bring against the Copernican System: With the An- swers the Copernicans give unto them.</i>	21
		<i>Of the Eclipses of the Sun and Moon, the Causes of them; and how, and when they happen.</i>	26

The CONTENTS.

Types of the Sun and Moon's Eclipse according to Ptolomy. 28	That Magnetical Virtue may be infused into Iron, without the help of the Load-stone. 4	
A Type of the Sun and Moon's Eclipse according to Copernicus. 29	Of the Attractive virtue of the Load-stone. <i>ibid.</i>	
Of the Passions of the Planets. 30	Of the Sympathy and Antipathy thereof. 5	
The Rudiments of Astronomy, in plain Rhyme. 32	Of the Cutting or Dividing of Load-stones. 6	
Of the Constellation of the Fixed Stars; giving an Account of the English, Greek, Hebrew, Latin, Arabick, Caldée, Syriack, Turkish, &c. Names; and of the most Eminent Stars in each of them: With the Poetical Fables; declaring how these Asterisms came to be placed in the Heavens; and also of the Galaxia. 35	To find the Poles of a Load-stone. <i>ibid.</i>	
TRACT. VI. Horometrical Recreations.		
T O make an Horizontal Dial in any Latitude. <i>Pag. n</i>	Of several Attempts that have been made to contrive a Perpetual motion by Magnetical Virtue. 7	
Of North and South Dials. 2	Of Magnetical Inclination, and thereby to find the Latitude at Sea, or on the Land. 9	
Of East, West and Polar Dials. 3	TRACT. IX. Chymical Recreations.	
Of Declining Dials. 5	O F Artificial Representations. <i>Pag. 1</i>	
Of Dialling Mechanical. 8	Of the Fire of Vestals. 2	
Of Projective Dials. 10	Of the Philosophet's Tree: To make it. <i>ibid.</i>	
Of Reflected Dials. 12	Of the Re-animation of Simples. <i>ibid.</i>	
Mechanically, to inscribe the Equinoctial Tropicks, and other Parallels of Declination, upon all sorts of Sun-Dials: And also the Azimths, Almican- ters, &c. 13	Of the representation of the Great World. 3	
Of several Night Dials, how to make and use them. 18	Of a famous Perpetual motion, invented by Cornelius Dreble; and made for K. James the First of England. 4	
Horometrical Tables of the Sun and Stars. 21	Of the making of Gold. <i>ibid.</i>	
Another Mechanical way to make Reflective Dials. 28	Of the Nature of Gold. 6	
TRACT. VII. Cryptographical Recreations.		
O F some Ancient ways of Secret Conveyance. <i>Pag. 1</i>	Of Incumbustible Flax: Or a Substance which will not be consumed by Fire. <i>ibid.</i>	
By the 24 Letters of the Common Alphabet variously disposed. 2	Of Subterraneous Lamps. 8	
By Transposition of the Alphabet. 7	TRACT. X. Automatical Recreations.	
By Astronomical Characters. 9	O F the Nature, and of the making of Clocks, Watches, and other Movements. <i>Pag. 1</i>	
By Knots tied upon a String. <i>ibid.</i>	Concerning Pendulums. 2	
By a New Character; easy to Learn, difficult to decipher; and yet Legible by the Motion of the Fingers. 11	Of finding out fit Numbers for Wheels and Pin- nions. 5	
Other ways of Secret Writing. 13	Of giving particular motion to any Movement. 8	
TRACT. VIII. Magnetical Recreations.		
O F the Magnet, its Name, &c. <i>Pag. 1</i>	To Regulate a true-made Pendulum Clock or Watch. <i>ibid.</i>	
That the whole Globe of the Earth hath true Magnetical Virtue. 3	A Table for the same. 10	
	Its Use. 11	
	TRACT. XI. Historical Recreations.	
	O F the Measures and Proportions of the several Members of Man's Body. <i>Pag. 1</i>	
	Of Men, or Giants of Prodigious Statures. 3	
	Of Dwarfs and Pigmies, &c. 4	
	Of Monsters, &c. 5	
	Of the Length of Age which Men lived in former Times, shortly after the Creation; and of others of later date. 10	
	Of the First Authors of divers famous Inventions. 13	

THE END.

ERRATA.

- In Numerical Recreations.
Page 41. line 20. read doubled.
- In Geometrical Recreations.
*Pag. 1. l. 20. read As the. p. 41. l. 29. r. points E and T. p. 15. l. 20. r. Marks H and L. p. 17. l. 14. r. 26 and 2d. p. 23. l. 27. r. one foot in V. p. 24. l. 5. r. (by Concl. IV.) p. 26. l. 20. r. (by Conclu. III.) p. 26. l. 33. r. a to e. p. 26. in the under Scheme M is wanting. p. 29. l. 16 r. erect a Perpendicular. p. 29. In the under Scheme P is wanting. p. 31. l. 43. r. points P. and S. p. 32. In the uppermost Scheme the Letters C and D are in each other's place. p. 37. l. 6, and 7. r. A, B, C and D. p. 38. The Letter M is wanting in the Scheme p. 39. l. ult. r. 297. 4 inches. p. 40. l. 24. r. distance C D p. 43. l. 32. r. as Figure X. p. 44. l. 13. the line ON. p. 44. l. 5. whereon. p. 45. l. 13. 75 Links. *Ibid.* in several places for 14 25625. r. 16. 25625.*
- p. 47. in the Scheme 8. 28 is wanting. p. 51. l. 6. r. *jud.*
 p. 59. l. 25. r. ABCDEFG.
- In Mechanical Recreations.
Pag. 14. l. pen. r. Wheels were augmented. p. 15. The Schemes belonging to Sect. 4. in that Page is omitted. p. 16. l. 22. r. Automata. p. 28. l. 13. r. The Figure of
- In Statical Recreations.
Page 3. line 26. r. Pendency.
- In Astronomical Recreations.
Page 35. line 22. read Galaxia.
- In Horometrical Recreations.
*Page 3. line 8. read (viz. 9, 10, 11 at Night, and 1, 2, 3 in the Morning.) p. 28. l. 14. r. Quadrant, or the like. p. *ibid.* l. 15. r. Day: And being.*
- In Magnetical Recreations.
Page 2. line 25. read Cynofura. p. 4. l. 29. r. it will there hold it. p. 9. l. ult. r. in this Table.

Arts and Sciences MATHEMATICAL

Professed and Taught by the AUTHOR.

- Arithmetick,** { In Whole Numbers, and Fractions.
 { In Decimals, and by Logarithms.
 { Instrumentally, by Decimal Scales, Napiers Bones: And to extract the Square and Cube-Roots by Inspection.
- Geometrie:** { The Principles thereof } Practice,
 { with the } and
 { } Demonstration.
 { Theoretical and Practical.
- Astronomie:** { The Description of the Circles of the Sphere.
 { The Use of the Globes, } Celestial, and
 { } Terrestrial.
 { To project the Sphere in *Plano* upon any Circle, } Right, of
 { } Oblique.

And upon these Foundations, the following Superstructures.

- The Use of Geometrical Instruments, in the Practice of**
- { *Longimetria*, or the Menfuration of { Heights, } as of { Trees, Towers, &c.
 { Depths, } { Mines, Wells, Descents, &c.
 { Distances, } { Churches, Towers, &c.
 - { *Planometria*, or the Menfuration of { Board, } Or any other Superficies.
 { Glafs, } { Pavement, }
 { Tiling, &c.
 - { *Stereometria*, or the Menfuration of { Timber, growing or squared.
 { Stone, regular or irregular.
 { Cask, commonly called Gaging.
 - { *Geodesia*, or the Measuring of Land divers ways, and by several Instruments; to draw the Plot of a whole Mannor or Lordship; to cast up the Content thereof; and to beautify the same with all necessary Ornaments thereunto belonging.
- Trigonometria:** { Or, the Menfuration of Triangles, both } Plain, and
 { } Spherical.
 { } Geometry.
 { } Astronomy.
 { The Application thereof, in the solution of Problems in } Geography.
 { } Navigation.
 { } Fortification.
 { } Dialling, &c.
- Navigation:** { The Principles thereof, and the manner of Sailing by } The Plain Sea-Chart.
 { } Mercator's Chart.
 { } The Arch of a great Circle.
- Diaſtigmographia,** { Arithmetically, by the Tables of } Sines.
 { } Tangents.
 { } Logarithms.
 { Or }
Dialling: { Geometrically, by } Scale, and
 { } Compasses.
 { Instrumentally, by the Sector, Quadrants, Scales, and other Instruments accommodated with Lines for that purpose.

BOOKS of this Author's already Extant.

HIS ARITHMETICK, in Four Parts, viz. *Vulgar, Decimal, Instrumental and Algebraical.* 8vo.

The Use of the *Line of Proportion*, made Easy, and by it to measure *Timber, Stone, Board, Glass, Pavement, Hangings, Wainscote, &c.* 12o.

His **COMPLETE SURVEYOR**: Teaching the Whole Art of *Surveying of Land*, by the *Plain Table, Theodolite, Circumferentor*, and other *Instruments.* In Five Books. Folio.

His *Arithmetical Recreations.* 12o.

His *Geometrical EXERCISES* for young Sea-men. 4to.

His *Geometrical Dialling.* 4to.

His *Platform for Purchasers, Guide for Builders, and Mate for Measurers.* 8vo.

His **PANORGANON**: Being the Description of a *Universal Quadrant*, and the Uses of it in *Geometry, Astronomy, Dialling, &c.* 4to.

His Use of the **GLOBES** in *Astronomy and Geography.* 8vo.

His **ASTROSCOPIUM**: Being the Description and Use of two *Hemispheres*, Projected upon the *Poles of the World.* 8vo.

His **DIALLING**, *Plain, Concave, Convex, Projective, Reflective and Refractive.* Folio.

His Second Part of the *Rule of Proportion.* 12o.

His **CURSUS MATHEMATICUS**:

Or, the *Mathematical Sciences*: so methodically disposed, as they ought to be *Read and Practised* by such as would attain to a competent proficiency in them by their own *Industry.* Folio.

His **RECREATIONS**, *Numerical, Geometrical, Mechanical, Statical, Astronomical, Horometrical, Cryptographical, Magnetical, Automastical, Chymical, Historical.* Folio.

His **PANARITHMOLOGIA**: A Book of *Accounts* ready cast up: Being a *Mirror for Merchants, a Breviate for Bankers, a Treasure for Tradesmen, a Platform for Purchasers or Mortgagees, &c.*

He hath now Preparing, and almost ready for the *Press*, These *Pieces* following, viz.

TRIGONOMETRIE, *Plain and Spherical*; all Geometrically demonstrated.

A Treatise **GEOMETRICAL**, of *Astronomie and Geography*, wholly designed for *Navigation*; wherein that Art will be rendered far more easy than hitherto it hath been usually *Taught or Practised.*

URANIA PRACTICA Rediviva.

ADVERTISEMENT.

THE Place of the *Author's* Residence is about Ten miles from *London* Westward, at a Place called *Southal*, in the Road between *Acton* and *Uxbridge*, and Three miles from *Brainford*: Where he intends to *Read the Mathematicks*, and Instruct young Gentlemen, and others: And to Board upon reasonable Terms, all such as shall be pleased to make a more close Application to those Studies: Where such Boarders, and others, (during their time of Residence with him) shall have the Use of all *Books, Maps, Globes*, and other *Mathematical Instruments*, as are necessary for their *Instruction*, till they provide themselves of such as they shall have occasion for afterwards.

You may hear of him, and have an Account of his Terms, and manner of Proceedings: By

Mr. Robert Morden, at the Sign of the *Atlas* in *Cornhill*, near the *Royal Exchange, Globe-maker.*

Mr. Henry Wyn, at the *Sugar-loaf* in *Chancery-Lane*, over against the *Rolls, Mathematical Instrument maker.*

Mr. John Thornton, near *Goodman's Yard* in the *Minories; Hydrographer.*

Mr. Henshaw, near the *Hermitage-Bridge* in *St. Katherine's.*

Numerical RECREATIONS.

CHAP. I.

Of *Digit, Article, Mixt, Square and Cube Numbers*; and some *Observations* upon them.

TO pass by the Common *Species and Rules of Arithmetick*, both *Vulgar and Decimal*, in *Whole Numbers and Fractions*; as also the *Extraction of the Square and Cube Roots*; supposing my Reader to be already acquainted with them; I shall proceed to treat of some other *Numerical Practices*, wherein the *Properties and Privileges* which some particular *Numbers* have over others; as also in the resolving of several *Enigmatical Questions*, to recreate the Spirits of the Ingenious Student in the *Art of Numbers*: And I shall begin with the *Nine Digits*, viz. 1, 2, 3, 4, 5, 6, 7, 8, 9.

I. Of the Digit 1.

The Digit 1 hath a Property which no other Number hath besides it self; for it neither Multiplieth nor Divideth, but leaveth the Number to be so Multiplied or Divided still the same: As if it were required to Multiply 365 by 1, it will still be but 365: Also if you were to Divide 365 by 1, the Quotient will be the same; for 1 may be had 365 times in 365; and 365 Unites that is multiplied by 1, maketh it no more than 365: And from hence it also followeth, that if any Number be divided by 1, there will nothing remain, whereas Numbers divided by any other Digit are liable to.

II. Of the Digit 2.

If you would multiply readily any number by the Digit 2, it is but doubling of that number; so 365 being doubled makes 730, which is equal to the Product of 365 multiplied by 2. — Also, if you would divide any number by 2, it is but taking the half of that number; so if 730 were to be divided by 2, the Quotient will be 365, for the half of 730 is 365. — But this Digit number 2 hath another Property or Privilege above any other Digit, Article, or Mixt Number; for there is no other whole Number to be found, which being added to it self, or

R E C R E A T I O N S

multiplied in it self, that shall produce the same number; but 2 added to 2, maketh 4 for the Sum; and 2 multiplied by 2, produceth 4 for the Product, which is also the Rectangle or Square of 2. — And it is moreover worth the taking notice of, That no Square Number, how large soever, can terminate or end with the Digit 2.

III. Of the Digit 3.

If you would multiply any number by 3, to the given number add the double thereof, and the Sum shall be equal to the Product; so 365 multiplied by 3, will be 1095; for the double of 365 is 730, to which 365 being added, the Sum is 1095; and so much would 365 multiplied by 3 produce. — Also, to divide any number by 3, take one third part thereof; so one third part of 1095 is 365, which is equal to the Quotient. And with this Digit 3, no Square Number can terminate.

IV. Of the Digit 4.

If you would multiply any number by 4, you must double the duplication thereof, and the Sum is the Product; so the double of 365 is 730, which doubled is 1460, and that is the Product of 365 multiplied by 4. — And if you would divide any number by 4, one fourth part thereof is the Quotient; so one fourth part of 1460 is 365, equal to the Quotient.

V. Of the Digit 5.

If you would multiply any number by 5, add a Cypher to the given number, then the half of that number will be equal to the Product; so 365 multiplied by 5, will produce 1825; for if to 365 you add a Cypher, it makes it 3650, the half whereof is 1825, equal to the Product. — On the contrary, if you would divide any number by 5, double the number, and cut off the last figure towards the right hand, (which will always be either a 5 or a Cypher) and the remainder shall be the Quotient. — So if you would divide 1825 by 5, the double of 1825 is 3650, from which cut off the 0 towards the right hand, and it leaves 365, equal to the Quotient.

VI. Of the Digit 6.

If you would multiply any number by 6, add a Cypher to the given number, and take the half thereof, to which add the given number, the Sum shall be equal to the Product of that number multiplied by 6: So if you would multiply 365 by 6, a Cypher added to the given number makes it 3650, the half whereof is 1825, to which 365 added, it makes 2190, equal to the Product of 365 multiplied by 6. — On the contrary, To divide any number by 6, take half the number, one third part of that half shall be the Quotient: So if you would divide 2190 by 6, the half of 2190 is 1095, one third part whereof is 365, equal to the Quotient.

I. Observation.

Between these two last mentioned *Digits* 5 and 6, there is a secret Property; for if you multiply either of them in themselves, the numbers produced by such multiplications shall terminate in themselves; so 5 multiplied in 5, produceth 25; and 6 multiplied in 6 produceth 36, terminating in themselves 5 and 6. — Also, if any greater numbers be multiplied by 5 or 6, they will continually terminate or end in 5 and 6; so 365 multiplied by 5, produceth 1825, terminating in 5; and 186 multiplied by 6, produceth 1116, terminating in 6.

II. Observation.

The number 6 hath another eminent Property, for all its aliquot parts are equal to himself; as his half (which is 3), his third (which is 2), and his sixth (which is 1), being added together, do make 6. And of Numbers that have this Property, there are but 10 to be found between *One*, and *One Million of Millions*, which are these exhibited in this following Scheme; and in these Numbers you may observe an Order; for every of the Odd Places, as the I, III, V, VII, and IX, do terminate in 6, whose half is 3, an Odd Number; and the Even Places, namely, the II, IV, VI, and VIII, do terminate in 8, the half whereof is 4, an even number. And if you will farther proceed to find more of these numbers, the 20th. number having this qualification, will be this,

I	6
II	28
III	486
IV	8128
V	120816
VI	2096128
VII	33550336
VIII	536854528
IX	8589869056
X	137438691328

15111577451553768931328.

VII. Of the Digit 7.

If you would multiply any number by 7, add a Cypher to the given number, and take the half thereof, to which half add the double of the number given, the Sum of them shall be the Product of the given number multiplied by 7. — So if you would multiply 365 by 7, add a Cypher to it, and it makes 3650, the half whereof is 1825, to which add 730, the double of 365 the given number, and the Sum will be 2555, which is the Product of 365 multiplied by 7. — On the contrary, if you would divide any number by 7. — Double the number given, and cut off the last figure to the right hand; then take the seventh part of that number and double it, and subtract it from the former number, the remainder shall be the Quotient. — So if you would divide 2555 by 7, that number doubled is 5110, from which cut off the Cypher to the right hand, and it is 511, one seventh part whereof is 73, the double whereof is 146, which subtracted from 511, the remainder is 365, and that will be the Quotient of 2555 being divided by 7. — And with this Digit 7, no Square Number can terminate.

VIII. *Of the Digit 8.*

To multiply any number by 8, double the number given, and subtract that double from the given number, (a Cypher being added to the given number), that Remainder shall be the Product of the given number, multiplied by 8. — So if you would multiply 365 by 8, the double of 365 is 730, a Cypher added to 365 is 3650, from which subtract the double of 365, namely, 730, and the remainder will be 2920, the Product of 365 multiplied by 8. — In like manner, if you would divide any number by 8, take half the number given successively three times, the third half shall be the Quotient of the given number divided by 8. — So if 2920 were a number given to be divided by 8, the half of it is 1460, the half of that is 730, and the half of that is 365, which is the Quotient of 2920 divided by 8. — And this Digit 8 hath another Property in it, for no Square Number can terminate with it.

IX. *Of the Digit 9.*

To multiply any number by 9, add a Cypher to the given number, and from that number subtract the given number, the Remainder shall be the Product. — So if you would multiply 365 by 9, add a Cypher to it, it makes 3650, from which subtract 365, and the remainder will be 3285, equal to the Product of 365 being multiplied by 9. — On the contrary, if you would divide any number by 9, take the third part of the given number twice successively, the second remainder shall be the Quotient: — So if you would divide 3285 by 9, one third of 3285 is 1095, and one third of 1095, is 365, which is the Quotient of 3285 divided by 9.

III. *Observation.*

☞ This Digit 9 hath a Privilege above all the other Digits; for if you take any number, the Nines taken out of the gross sum of that number, or of all the parts thereof severally, the remaining Digit will be still the same: *Example*; In the number 36 there are 4 Nines contained therein; and so if you multiply 9 by 4, it will produce 36; and if you take the Nines out of 36, they are four also. — In like manner, if you take the Nines out of this number 248, it is all one as if you should take the Nines out of the simple figures 2, 4, and 8, which do make 14, from which 9 being taken, there will remain the Digit 5; and also if you divide 248 by 9, the Quotient will be 27, which shews that there are 27 times 9 in 248, and the Digit 5 remaining.

X. *How the Nine Digits may be disposed in such Order, that the Number 15 shall be accounted in Rank, File, and Diagonally, 32 times.*

In the Nine Digits there are Four Even, and Five Odd; now if you set the four Even Digits, 2, 4, 6, and 8, at the four corners of a Square, and 5 (which is the middlemost of the five odd Digits) in the Center
or

NUMERICAL.

or middle of the Square, as is done in the Margent then between every two even Digits put such an odd Digit as shall make the number in that line both in Rank and File 15; as between 2 and 4, put 9, which together make 15, and so the rest; the which 9 Digits thus disposed, 15 may be accounted in *Rank*, *File*, and *Diagonally*, 32 times: Example,

	Rank	
	2 9 4	
File	7 5 3	File
	6 1 8	
	Rank	

In Rank,

Rank $\left. \begin{matrix} 2 & 9 & 4 \\ 4 & 9 & 2 \\ 9 & 2 & 4 \\ 9 & 4 & 2 \end{matrix} \right\} \text{equal to } 15.$	Rank $\left. \begin{matrix} 7 & 5 & 3 \\ 3 & 5 & 7 \\ 5 & 7 & 3 \\ 3 & 7 & 5 \end{matrix} \right\} \text{equal to } 15.$	Rank $\left. \begin{matrix} 6 & 1 & 8 \\ 8 & 1 & 6 \\ 1 & 6 & 8 \\ 8 & 6 & 1 \end{matrix} \right\} \text{equal to } 15.$
--------------------------------------------------------------------------------------------------------------------------	--------------------------------------------------------------------------------------------------------------------------	--------------------------------------------------------------------------------------------------------------------------

In File,

File $\left. \begin{matrix} 2 & 7 & 6 \\ 6 & 7 & 2 \\ 7 & 2 & 6 \\ 6 & 2 & 7 \end{matrix} \right\} \text{equal to } 15.$	File $\left. \begin{matrix} 9 & 5 & 1 \\ 1 & 5 & 9 \\ 5 & 1 & 9 \\ 5 & 9 & 1 \end{matrix} \right\} \text{equal to } 15.$	File $\left. \begin{matrix} 4 & 3 & 8 \\ 8 & 3 & 4 \\ 3 & 4 & 8 \\ 3 & 8 & 4 \end{matrix} \right\} \text{equal to } 15.$
--------------------------------------------------------------------------------------------------------------------------	--------------------------------------------------------------------------------------------------------------------------	--------------------------------------------------------------------------------------------------------------------------

Diagonally,

Diagonal Dexter, $\left. \begin{matrix} 2 & 5 & 8 \\ 8 & 5 & 2 \\ 5 & 2 & 8 \\ 5 & 8 & 2 \end{matrix} \right\} \text{equal to } 15.$	Diagonal Sinister, $\left. \begin{matrix} 4 & 5 & 6 \\ 6 & 5 & 4 \\ 5 & 4 & 6 \\ 4 & 6 & 5 \end{matrix} \right\} \text{equal to } 15.$
--------------------------------------------------------------------------------------------------------------------------------------	----------------------------------------------------------------------------------------------------------------------------------------

IV. Observation.

☞ There is a notable harmony between some Numbers, as particularly in these two, 220 and 284: For the addition of the Aliquot Parts of the one, do make up the Sum of the other: So

The Aliquot Parts of 220 are	110 55 44 22 20 11 10 5 4 2 1
------------------------------	-------------------------------------------------------------

Whose Sum is 284

The Aliquot Parts of 284 are,	142 71 4 2 1
-------------------------------	--------------------------

Whose Sum is 220

R E C R E A T I O N S

XI. Of the Article Numbers, 10, 100, 1000.

If you would multiply any number by 10, 100, or 1000, &c. it is done by adding of so many Cyphers towards the right hand of the given number, as there are Cyphers in the Article number by which you are to multiply: So

$$\text{If you are to multiply } \left. \begin{array}{l} 365 \\ 7642 \\ 96421 \end{array} \right\} \text{ by } \left. \begin{array}{l} 10 \\ 100 \\ 1000 \end{array} \right\} \text{ the Product will be } \left. \begin{array}{l} 3650 \\ 764200 \\ 96421000 \end{array} \right\}$$

On the contrary, any number may be divided by an *Article Number*, by cutting off from the given number so many figures towards the right hand, as there are *Cyphers* in the *Article Number* by which you are to divide: So

$$\text{If you would divide } \left. \begin{array}{l} 7628 \\ 34086 \\ 932073 \end{array} \right\} \text{ by } \left. \begin{array}{l} 10 \\ 100 \\ 1000 \end{array} \right\} \text{ the Quotient will be } \left. \begin{array}{l} 762. \frac{8}{10} \\ 340. \frac{86}{100} \\ 932. \frac{073}{1000} \end{array} \right\}$$

And the like of any other.

XI. Of the Numbers 11, 12, 13, 14, 15, 16, 17, 18, and 19.

If you would multiply any number by any of these numbers that hath a *Unite* in the *Tenth* place, observe the method following, where you may set down the *Product* in one single line; as in the *Margent*;

786 Let 786 be a number given to be multiplied by 12; set
12 them down as in the *Margent*, and say, Two times 6 is 12;
— set down 2, and keep 1 in mind: — Then, 2 times 8 is 16,
9432 and 1 in mind is 17, and 8 over the 1, is 23; set down 3,
 and bear 2 in mind: Then, 2 times 7 is 14, and 2 in mind is
16, and 8 over 1 is 24: set down 4, and bear 2 in mind; which 2 add
to the last figure 7, it makes 9; so that 786 multiplied by 12, produ-
ces 9432. And so of others; as in Examples,

$$\begin{array}{r} 4264 \\ 16 \\ \hline 68224 \end{array}$$

$$\begin{array}{r} 60304 \\ 19 \\ \hline 1145776 \end{array}$$

XII. Of

NUMERICAL.

XII. Of Square and Cube Numbers.

It is observed before, that no Square Number, can terminate in any of these four Digits 2, 3, 7, or 8: Notwithstanding, there are many subtle Properties in Square Numbers: As,

1. If from an Unite you do successively add the next odd digit number, the sum of those two Numbers shall produce Square Numbers: As, if to 1 you add 3, the next odd number, the Sum is 4, a Square Number; to which if you add 5, the next odd Digit, it makes 9, a Square Number; to which if you add 7, the next odd Digit, it makes 16, a Square Number; and so on, as in this little Table,

For	1	and	3	}	makes	4	A Square Number.
	4		5			9	
	9		7			16	
	16		9			25	
	25		11			36	
	36		13			49	
	49		15			64	
	64		17			81	
	81		19			100	

2. If a Series of Eleven Square Numbers be orderly set one under another, the terminating figure of the first, and the terminating figure of the last shall be the same. And so if the terminating figure of the first number be a Cypher, the second shall be 1, the third 4, the fourth 9, the fifth 6, the sixth (or middlemost) 5, the seventh 6, the eighth 9, the ninth 4, the tenth 1, the eleventh 0, as in this Table. So likewise if Cube Numbers be successively added from Unity, those Numbers shall also be Square Numbers.

80	6400
81	6561
82	6724
83	6889
84	7056
85	7225
86	7396
87	7569
88	7744
89	7921
90	8100

R E C R E A T I O N S

XIII.

A Table of the Nine Digits, each of them being Multiplied into all the Nine Digits, and the several Products of those Multiplications Added.

I.				II.				III.			
1	1	1	1	1	2	2	2	1	3	3	3
2	1	2	2	2	2	4	4	2	3	6	6
3	1	3	3	3	2	6	6	3	3	9	9
4	1	4	4	4	2	8	8	4	3	12	3
5	1	5	5	5	2	10	1	5	3	15	6
6	1	6	6	6	2	12	3	6	3	18	9
7	1	7	7	7	2	14	5	7	3	21	3
8	1	8	8	8	2	16	7	8	3	24	6
9	1	9	9	9	2	18	9	9	3	27	9
		<u>45</u>	45			<u>90</u>	45			<u>45</u>	54
IV.				V.				VI.			
1	4	4	4	1	5	5	5	1	6	6	6
2	4	8	8	2	5	10	1	2	6	12	3
3	4	12	3	3	5	15	6	3	6	18	9
4	4	16	7	4	5	20	2	4	6	24	6
5	4	20	2	5	5	25	7	5	6	30	3
6	4	24	6	6	5	30	3	6	6	36	9
7	4	28	1	7	5	35	8	7	6	42	6
8	4	32	5	8	5	40	4	8	6	48	3
9	4	36	9	9	5	45	9	9	6	54	9
		<u>180</u>	45			<u>225</u>	45			<u>270</u>	54
VII.				VIII.				IX.			
1	7	7	7	1	8	8	8	1	9	9	9
2	7	14	5	2	8	16	7	2	9	18	9
3	7	21	3	3	8	24	6	3	9	27	9
4	7	28	1	4	8	32	5	4	9	36	9
5	7	35	8	5	8	40	4	5	9	45	9
6	7	42	6	6	8	48	2	6	9	54	9
7	7	49	3	7	8	56	1	7	9	63	9
8	7	56	1	8	8	64	0	8	9	72	9
9	7	63	9	9	8	72	9	9	9	81	9
		<u>315</u>	43			<u>360</u>	42			<u>405</u>	81

XIV. *Some Remarks upon the Nine Digits, as they are disposed in the Table.*

I. *Of the Digit 1.*

Little can be said concerning this *Digit*, for that it neither Multiplieth nor Divideth, but leaveth the Number which is Multiplied or Divided still the same: But this you may take notice of, That any two Terms, taken equidistant from the Middle Term, do make 10, and the Middle Term (which is 5) doubled does make 10 also.

$$\text{So the } \left. \begin{array}{l} 1 \\ 2 \\ 3 \\ 4 \end{array} \right\} \text{ and } \left. \begin{array}{l} 9 \\ 8 \\ 6 \\ 5 \end{array} \right\} \text{ are every of them equal to } 10.$$

Again; If you Multiply the last term (9) by the middlemost term (5), that Product shall be equal to the Sum of all the Products added together; for 1, 2, 3, 4, 5, 6, 7, 8, and 9, added together, do make 45.

Also, If you leave out the last term (9), and take the two extremes successively, and add them together, every of their Sums shall be equal to 9.

$$\text{As } \left. \begin{array}{l} 8 \\ 7 \\ 6 \\ 5 \end{array} \right\} \text{ and } \left. \begin{array}{l} 1 \\ 2 \\ 3 \\ 4 \end{array} \right\} \text{ are all of them equal to } 9.$$

II. *Of the Digit 2.*

In the Addition of the Products of the Multiplication of this *Digit*, you have one of every of the Nine Digits, tho not orderly disposed, yet they stand so, that if you add the two extreme terms equidistant from the middle term together, the Sum of each of them shall be equal to (11).

$$\text{So } \left. \begin{array}{l} 9 \\ 8 \\ 7 \\ 6 \end{array} \right\} \text{ and } \left. \begin{array}{l} 2 \\ 3 \\ 4 \\ 5 \end{array} \right\} \text{ are each of them equal to } 11.$$

And if you leave out the last term 9, then every two extreme terms taken together, shall be equal to (9) the last term.

$$\text{As } \left. \begin{array}{l} 2 \\ 4 \\ 6 \\ 8 \end{array} \right\} \text{ and } \left. \begin{array}{l} 7 \\ 5 \\ 3 \\ 1 \end{array} \right\} \text{ each equal to } 9.$$

And again, If you add the numbers in the fourth row under this *Digit* together, you will find the Sum of them to be 45, which multiplied
B
by

R E C R E A T I O N S

by the Digit (2) makes 90, equal to the Sum of the Products of all the Multiplications of this Digit, which stand in the third Row under Digit II.

III. Of the Digit 3.

In this Digit you may observe (as in all the rest) that the Products of the several Multiplications do proceed in an *Arithmetical Progression*, the Common Difference being that of the Digit: So in this of the Digit (3). Wherefore if you add any two terms equidistant from the middle term, the Sum of those two terms shall be equal, and the double of the middle term equal thereunto also: So in this

$$\begin{array}{r}
 3 \\
 6 \\
 9 \text{ and } 21 \\
 12 \\
 15 \text{ doubled}
 \end{array}
 \left. \begin{array}{l}
 27 \\
 24 \\
 21 \\
 18
 \end{array} \right\} \text{ are all equal to } 30.$$

In this Digit you may observe, that all the Additions of the Products are one of these three Digits, viz. 3, 6, or 9; and now if you multiply every one of these severally by (3) the common difference, the Products of each of them will be 9, 18, 27; which added together do make 54, which is equal to the Sum of the fourth Row under this Digit (3). And in this fourth Row of Additions, if you add the two extrem terms, as 3 and 9 together, their Sum will be 12, to which the middle term (6) doubled, is also equal.

IV. Of the Digit 4.

In the fourth Row under this Digit (4) you have all the 9 Digits produced; and if you omit the last term, every two of the rest added together shall be equal to 9; and the Sum of all that Row added together makes 45; which if you multiply by the digit (4), the Product will be (180) equal to the third Row of all the Products added together.

V. Of the Digit 5.

This Digit hath all the Nine Digits in the fourth Row of Additions (as the First, Second, and Fourth had), and therefore hath the same qualifications; for omitting the last term, every two figures taken equidistant from the extremities, shall be equal to (9), and the Sum of all that Row shall be (45); which multiplied by the common difference (5) the Product shall be (225) equal to the Sum of all the Products of the Multiplications in the third Row. In which Row also, if you add the two extrem terms together (5 and 45), the Sum of them is (50), and is equal to the double of the middle term (25) And so also in the fourth Row, if you add the two extrem Digits (9 and 5) together, their Sum (14) shall be equal to the double of the middle term (7).

VI. Of

VI. *Of the Digit 6.*

This Digit hath the same qualifications as had the Digit (3), for all the fourth Row of Additions are one of these Digits 6, 3, or 9: And omitting the last term, every two terms taken equidistant from the extreams, shall be equal to 9, and the sum of all of them equal to 54, equal to the last number of the third row: And in the third row, if you add any two numbers equidistant from the two extreams, their sum will be 60, equal to the double of the middle term (30). And farther; the sum of the fourth row being (54), that multiplied by (5), a number less by one than (6) the common difference, (because it exceeds 5), the Product will be 270, equal to the sum of all the Products in the third row.

VII. *Of the Digit 7.*

In this Digit (as in all the rest) the third row, which proceeds by multiplying of the Digit 7 into all the other Digits, descends in Arithmetical Progression, the common difference being (7); and so if you add the two extream numbers together, as (7) and (63), the sum of them will be (70), which will be equal to the double of the middle number (35). And the like will be by the addition of any two of them equidistant from the two extreams, or from the middle number,

$$\text{As } \left\{ \begin{array}{l} 14 \\ 21 \\ 28 \end{array} \text{ and } \left\{ \begin{array}{l} 56 \\ 49 \\ 42 \end{array} \right. \right\} \text{ are all of them equal to } 70.$$

And so is the double of (35 the middle term also) equal to 70.

Again; the last number in the third being (63) multiply it by (5), a number less by 2 than the common difference, and the Product will be (315) equal to the sum of all the Products in that third row added together.

VIII. *Of the Digit 8.*

In this the third Row increases by an Arithmetical Progression, the common difference being (8); so that the two extream terms (8 and 72) being added together, do make (80), equal to the double of the middle term (40), and so any two that are equidistant from the middle term: And for the sum of them, multiply the last term (72) by (5) and the Product will be (360) equal to the sum of all the Products in the third row: And for the fourth row, they all descend till they come to (0) the last being (9) as it is in all the other Unites.

IX. *Of the Digit 9.*

The third row under this Digit proceeds in an Arithmetical Progression, so that the two extream terms (8 and 81) make (90), equal to the double of (45) the middle term; and so do any two of the rest that are taken equidistant from both the extreams, or from the middle

term (45): And for the sum of the numbers in this third row, the last number (81) multiplied by (5) gives (405) for the sum of all that row. As for the numbers (or Sums) in the fourth row, they are all equal one to the other, namely (9), and they being all added together, their sum is equal to the last term in the third row.

C H A P. II.

Of Comparative Arithmetick; or of the Relation of Numbers in Quantity.

Comparative Arithmetick is performed by Numbers, as they are considered to have relation one to another in *Quantity* or *Quality*.

1. *Relation in Quantity*] is the reference or respect that the Numbers themselves have one to another: As when the comparison is made between 6 and 2, or 2 and 6; — 5 and 3, or 3 and 5. And here the numbers propounded are always two, whereof the first is called the *Antecedent*, and the second the *Consequent*; so in the first *Example* 6 is the *Antecedent*, and 2 the *Consequent*; and in the second, 2 is the *Antecedent*, and 6 the *Consequent*.

2. *Relation in Quality*], consists either in the *Difference*, or else in the *Rate* or *Reason* that is found between the Terms propounded.

3. *Difference*.] The *Difference* of two numbers is the remainder which is left after Subtraction of the lesser out of the greater; so 6 and 2 being the Terms propounded, 4 is the *Difference* between them, for 2 subtracted from 6, the remainder is 4.

4. *Rate* or *Reason*.] The *Rate* or *Reason* between two numbers, is the *Quotient* of the *Antecedent* divided by the *Consequent*: So if it be demanded what *Rate* or *Reason* 6 hath to 2; the *Answer* is, *Triple Reason*; for if you divide the *Antecedent* 6, by the *Consequent* 2, the *Quotient* will be 3, 2 being contained in 6 just three times. — In like manner is there sub-triple *Reason* between 2 and 6; for if you divide 2 by 6, the *Quotient* is $\frac{2}{6}$, or $\frac{1}{3}$, because 6 being not found once in 2, there remains 2 for *Numerator*, 6 the *Divisor* being the *Denominator*.

This *Rate* or *Reason* of Numbers is either *Equal*, or *Unequal*.

5. *Equal Reason*] Is the relation that equal numbers have one to another, as 5 to 5, — 6 to 6, — 7 to 7, &c. For here, one being divided by the other, the *Quotient* is always an *Unit*; for if it be demanded, how often 5 may be had in 5, the *answer* will be, 1, or *Unity*.

6. *Unequal Reason*] is the relation that unequal numbers have one unto another; and this is either of the *Greater* to the *Lesser*, or of the *Less* to the *Greater*. — *Unequal Reason of the Greater to the Lesser*], is, when the greater term is *Antecedent*, as of 6 to 2, or 9 to 7, and the like; for here the *Quotient* of the *Antecedent* divided by the *Consequent*, is always greater than *Unity*; so 6 divided by 2, the *Quotient* is 3, and 9 divided by 7, is $1\frac{2}{7}$. — But *Unequal Reason of the Lesser to the Greater*], is, when the lesser term is *Antecedent*, as of 2 to 6, or 7 to 9, &c. — And here the *Quotient* of the *Antecedent* divided by the

the Consequent, is always less than Unity ; so 2 divided by 6, the Quotient is $\frac{2}{6}$, or $\frac{1}{3}$, and 7 divided by 9, is $\frac{7}{9}$

Each of these kinds of *Unequal Reason* is again subdivided into Five other kinds or varieties ; whereof the three first are *Simple*, and the other two are *Mixt*. — The Simple kinds of *Unequal Reason* are, (1.) *Manifold*. (2.) *Superparticular*. (3.) *Superpartient*.

7. *Manifold Reason of the Greater to the Less*], is when the Consequent is contained in the Antecedent divers times, without any part remaining ; as 4 to 2, 8 to 4, 16 to 8 ; which is called *Double Reason*, because the Less is contained twice in the Greater ; so 6 to 2 is *Triple Reason*, and 8 to 2 *Fourfold Reason*, &c. And here, the Quotient of the Antecedent divided by the Consequent, is always a whole number ; as 8 divided by 2, the Quotient is 4, a whole number. — The opposite of this kind, *viz.* Of the *Less* to the *Greater*, is called *Sub-manifold* ; Examples hereof are, 2 to 4, 4 to 8, 8 to 16, &c. Also 2 to 6, 2 to 8, 2 to 10, &c.

8: *Superparticular Reason of the Greater to the Lesser*], is, when the Antecedent contains the Consequent once ; and besides, an Aliquot part of the Consequent ; that is, one half, one third, one fourth, or one fifth, &c. of the Consequent ; as 3 to 2, 4 to 3, 5 to 4, 6 to 5, and the like : So here, 3 divided by 2, the Quotient is $1\frac{1}{2}$; and 4 divided by 3, the Quotient is $1\frac{1}{3}$; 5 by 4, the Quotient is $1\frac{1}{4}$; wherefore I say, 2 and half 2 (which is 1) do constitute 3 ; so 3, and $\frac{1}{3}$ of 3 do constitute 4 ; and so of the rest. — For here, the Quotient of the Antecedent divided by the Consequent, is a Mixt Number, whose whole part, and the Numerator of the Fraction, is always an Unite. — The opposite Reason of this kind is *Subsuperparticular*, as 2 to 3, 3 to 4, 4 to 5, 5 to 6, &c.

9. *Superpartient of the Greater to the Less*], is, when the Antecedent contains the Consequent once, and divers parts of the Consequent besides ; as 5 to 3, 7 to 5, 7 to 4, 8 to 5, 9 to 5, 11 to 7, &c. Here 5 divided by 3, the Quotient is $1\frac{2}{3}$, and therefore 5 contains 3 once, and $\frac{2}{3}$ of 3, which is 2, and they two together do constitute 5. — Here the Quotient of the Antecedent divided by the Consequent, is a *Mixt Number*, whose whole part being a Unite, hath always for the Numerator of the Fraction a Number composed of more Unites than one ; so the conference being made between 5 and 3, and 5 the Antecedent being divided by 3 the Consequent, the Quotient is $1\frac{2}{3}$. — The opposite of this Reason is *Subsuperpartient* ; Examples hereof are, 3 to 5, 5 to 7, 4 to 7, 5 to 8, 5 to 9, 7 to 11, &c.

The Mixt kinds of *Unequal Reason* are two, *viz.* (1.) *Manifold Superparticular*. And (2.) *Manifold Superpartient*.

10. *Manifold Superparticular Reason*], is, when the Antecedent contains the Consequent divers times, and an *Aliquot part* of the Consequent besides ; as 5 to 2, 10 to 3, 17 to 4, 21 to 5, and the like. — Here the Quotient of the Antecedent divided by the Consequent, is a Mixt Number, whose whole part consisting of more Unites than one, hath always an Unite for the Numerator of the Fraction annexed unto it ; so 5 divided by 2, hath for the Quotient $2\frac{1}{2}$, and 21 divided by 5, the Quotient

ent is $4\frac{1}{3}$. — And the opposite of this Reason is *Submanifold Superparticular*; as 2 to 5, 2 to 7, 3 to 7, 4 to 9, &c.

II. *Manifold Superpartient Reason*], is, when the Antecedent contains the Consequent divers times; and divers parts of the Consequent befits; as 8 to 3, 17 to 5, 19 to 4, 28 to 5, &c. — Here the Quotient of the Antecedent divided by the Consequent, is a Mixt Number, whose whole part, as also the Numerator of the Fraction annexed unto it, is always a number composed of more Unites than one: — So 8 divided by 3, the quotient is $2\frac{2}{3}$, and 28 by 5, the quotient is $5\frac{3}{5}$, &c. — And the opposite hereof is *Submanifold Superpartition*; as 3 to 8, 5 to 17, 4 to 19, 5 to 28, and the like.

These are the several *Varieties* of the *Rates* or *Reasons* that are found among *Numbers*; so that no two *Numbers* can be named, but the *Rate* or *Reason* between them is comprehended under one of these last Five Heads.

C H A P. III.

Of Arithmetical, Geometrical, and Musical Proportions.

I. Of Arithmetical Proportion.

A *Arithmetical Proportion* (or *Habitude*) is an equality of *Differences*: That is to say, when several *Numbers* have one and the same *Difference*: And this *Habitude* is twofold, *viz.* (1.) *Continued*. (2.) *Discontinued*.

1. *Arithmetical Proportion Continued*], is, when of several *Numbers*, the Second exceedeth the First, by the same number of *Unites*, as the Third exceeds the Second, and as the Fourth doth the Third; and so *in infinitum*.

As thus,

1, 2, 3, 4, 5, 6, 7, 8, 9, 10, 11, 12, &c. do differ from each other by (1), or One Unite. And 1, 3, 5, 7, 9, &c. differ by (2) or Two Unites. Also 1, 6, 11, 16, 21, 26, &c. differ by (5) or Five Unites. And this Orderly proceeding of *Numbers* from the lesser to the greater, is that which we properly call *Arithmetical Progression*.

2. *Arithmetical Proportion Discontinued*], is, when the Second *Number* exceeds the First, by the same number of *Unites* as the Fourth doth the Third; but not as the Third doth the Second.

As for Example;

1, 3, 7, 9, are four distinct *Arithmetical Proportionals Discontinued*. — For 3 exceeds 1 by the same number of *Unites* (*viz.* 2.) as 9 exceeds 7, but not as 7 doth 3. — So again, 2, 7, 10, 15, are four *Arithmetical Proportionals Discontinued*; for 7 exceedeth 2 by (5), and so doth 15 exceed 10; but 10 doth not exceed 7 by (5), but by (3). And this is *Arithmetical Proportion Discontinued*.

II. Of

II. Of Geometrical Proportion.

Geometrical Proportion, or Habitude,] is the equality of *Ratio's*; or it is that which shews what part or parts one Number is of another; — Or more plainly thus; It is an Increase by a *Common Multipli-*
cation.

So these Numbers, 1, 2, 4, 8, 16, 32, 64, &c. are Numbers in *Geometrical Proportion.* where the *Common Multiplier* is [2], that is, the first multiplied by 2, produceth the second; the second multiplied by 2, produceth the third, and so on *in infinitum.* — Or in these Numbers, 3, 9, 27, 81, 243, &c. where the *Common Multiplier* is [3.] And this is called *Geometrical Progression.*

Of both these kinds of Progression I have inserted Tables.

Arithmetical Progression, the Common Difference being

One	Two	Three	Four	Five	Six	Seven	Eight	Nine	Ten
1	2	3	4	5	6	7	8	9	10
2	4	6	8	10	12	14	16	18	20
3	6	9	12	15	18	21	24	27	30
4	8	12	16	20	24	28	32	36	40
5	10	15	20	25	30	35	40	45	50
6	12	18	24	30	36	42	48	54	60
7	14	21	28	35	42	49	56	63	70
8	16	24	32	40	48	56	64	72	80
9	18	27	36	45	54	63	72	81	90
10	20	30	40	50	60	70	80	90	100
11	22	33	44	55	66	77	88	99	110
12	24	36	48	60	72	84	96	108	120
13	26	39	52	65	78	91	104	117	130
14	28	42	56	70	84	98	112	126	140
15	30	45	60	75	90	105	120	135	150
16	32	48	64	80	96	112	128	144	160
17	34	51	68	85	102	119	136	153	170
18	36	54	72	90	108	126	144	162	180
19	38	57	76	95	114	133	152	171	190
20	40	60	80	100	120	140	160	180	200
21	42	63	84	105	126	147	168	189	210
22	44	66	88	110	132	154	176	198	220
23	46	69	92	115	138	161	184	207	230
24	48	72	96	120	144	168	192	216	240
25	50	75	100	125	150	175	200	225	250

RECREATIONS

Geometrical Progression.

1	1	1
2	3	4
4	9	16
8	27	64
16	81	256
32	243	1,024
64	729	4,096
128	2,187	16,384
256	6,561	65,536
512	19,683	262,144
<hr/>		
1	1	1
5	6	7
25	36	49
125	216	343
625	1,296	2,401
3,125	7,756	16,807
15,625	46,536	117,649
78,125	279,216	823,543
390,625	1,675,296	5,764,801
1,953,125	10,651,776	40,353,607
<hr/>		
1	1	1
8	9	10
64	81	100
512	729	1,000
4,096	6,561	10,000
32,768	59,049	100,000
262,144	531,441	1,000,000
2,097,152	4,782,969	10,000,000
16,777,216	43,046,721	100,000,000
134,217,728	387,420,489	1,000,000,000

	10	1
	100	2
	1,000	3
	10,000	4
	100,000	5
	1,000,000	6
	10,000,000	7
	100,000,000	8
	1,000,000,000	9
	10,000,000,000	10
	100,000,000,000	11
	1,000,000,000,000	12
	10,000,000,000,000	13
	100,000,000,000,000	14
	1,000,000,000,000,000	15
	10,000,000,000,000,000	16
	100,000,000,000,000,000	17
	1,000,000,000,000,000,000	18
	10,000,000,000,000,000,000	19
	100,000,000,000,000,000,000	20
	1,000,000,000,000,000,000,000	21
	10,000,000,000,000,000,000,000	22
	100,000,000,000,000,000,000,000	23
	1,000,000,000,000,000,000,000,000	24
	10,000,000,000,000,000,000,000,000	25

Geometrical Progression.

Arithmetical Progression.

In this *Progression* it is visible, how *Addition* and *Subtraction* in *Arithmetical Progression*, answers to *Multiplication* and *Division* in *Geometrical Progression*. — For, As in *Geometrical Progression*, 1000 multiplied by 100,000, produces 100,000,000: So in *Arithmetical Progression*, the numbers answering to 1000, and 100,000, are (3) and (5,) which being added together make (8,) which answers to this Product 100,000,000. — And again, As in *Geometrical Progression* (100,000,000) being divided by (100,000) the *Quotient* is (1000.) So in *Arithmetical Progression*, If from the correspondent number, belonging to the former Product 100,000,000, (*viz.* 8,) you subtract any of the other correspondent numbers, *viz.* (5,) the remainder will be the other correspondent number (*viz.* 3,) which answers to 1000.

III. Of Musical Proportion.

Musical Proportion or Habitude,] is, when the first number hath the same proportion to the third, which the difference between the first and second hath to the difference between the second and the third.

As in these numbers [3, 4, 6,] whereas 3 is the half of 6: So 1, which is the difference between 3 and 4 the half of 2.

C H A P. IV.

Numerical Theorems.

I. If Numbers (*how many soever*) exceed one another by an equal Interval; the Interval between the Greatest and the Least, is Multiplex of that equal Interval: according to the multitude of the Numbers propounded, less by One.

LET the numbers proposed be these four 1, 3, 5, 7, whose common Interval is 2. Then (by the *Hypothesis*) 6 is the Interval between the Greatest 7, and the Least 1. — And likewise the three numbers 2, 2, 2, are every of them equal to the common difference, and equal one to the other. And the multitude of them (*viz.* three) equal to the multitude of the number given, (*viz.* four) less by One. — And lastly, The Aggregate of these three numbers (*viz.* six) is equal to the Interval between 7 the Greatest, and 1 the Least, *viz.* 6.

II. If Numbers (*how many soever*) contain the one the other by an equal Ratio, then the Greatest of those Numbers, is Multiplex of the Powers of the Denomination of that equal Ratio multiplied by the Least; according to the Multitude of the Numbers given, less by One.

LET the Numbers given be these four, *viz.* 2, 6, 18, 54. And let the Denomination of the Ratio be 3. Then (by the *Hypothesis*) the first multiplied by 3 (the equal Ratio) is equal to the second (*viz.* 6,) and the second multiplied by (3) is equal to the third (*viz.* 18) and the third multiplied by (3) is equal to the fourth (*viz.* 54.) *Et sic, &c.*

The	First	Term	2	is equal to	2.		
	Second		6			2 into 3. (The first Power of the Ratio, or the single Ratio.	
	Third		18				2 into 3, into 3. (The second Power of the Ratio, or the Ratio squared.
	Fourth		54				

Or, let the four Numbers be 1, 3, 5, 7, and the common difference 2. Then,

The	First	Term	1	is equal to	1		
	Second		3			1 more by 2.	
	Third		5				1 more by 2, more by 2.
	Fourth		7				

Here the Greatest Term (7) is equal to the Least (1,) and as many differences as there are more Terms besides the Least (*viz.* six.) And therefore the Greatest Term 7, less by the Least 1, (*viz.* 6) is *Multiplex* of the Difference, according to the number of Terms less by One.

III. *If there be three Numbers in Arithmetical Proportion; the Sum of the two Extreams is equal to the double of the Means.*

LET the three Numbers be 2, 4, 6, whose common difference is 2. Then,

The first Term 2, is only 2.

The second Term is 2, more by the difference once (*viz.* 4)

The third Term is 2, more by the difference twice (*viz.* 6.)

And so it is evident, that twice (2) the first Term, more by twice the difference (4) is equal both to the Sum of the first and third Terms; and also to the double of the mean term (4,) for 2 and 6 is 8; and so also is the double of 4.

IV. *If three Numbers be in Proportion, the Number contained under the Extreams, is equal to the Square made of the Mean: And if the Number contained under the Extreams, be equal to the Square of the Mean, those three Numbers shall be in proportion.*

LET the three Numbers be (2, 6, 18.)

And let the common Ratio be (3.)

The first Term is (2.)

The second Term is 2 into 3 (*viz.* 6.)

The third Term is 2 into the Square of 3 (*viz.* 9) equal to 18.

And from hence it is evident, That the first Term drawn into the third (*viz.* 2 into 18,) is equal to 2 into 2 (*viz.* 4,) and that into the Square of 3 the common Ratio (*viz.* 9) For 2 into 18 is equal to (36.) And so is 4 the square of 2, into 9 the square of 3 equal to 36. Therefore, the Product of the first multiplied by the third, is equal to the square of the Mean.

V. *If*

V. *If there be four Numbers in Arithmetical Proportion; the Sum of the first and fourth, is equal to the Sum of the second and third.*

LET the four Numbers be in continual Proportion, as these 4, 12, 20, 28, whose common difference is (8.)

The { First } Term is { 4.
 Second } { 4, and once the Difference 8, (viz. 12.)
 Third } { 4, and twice the difference 16, (viz. 20.)
 Fourth } { 4, and thrice the Difference 24, (viz. 28.)

Again, Let the four Numbers be four discontinued Proportionals; as these, 4, 12, 30, 38. And their common difference (8.) Then

The { First } Term is { 4.
 Second } { 4, and once the Difference 8, (viz. 12.)
 Third } { 30.
 Fourth } { 30, and once the Difference 8, (viz. 38.)

In the four *Continual Proportions* 4, 12, 20, 28 it is evident, That twice the first term 4 (viz. 8,) more by thrice the difference 8 (viz. 24,) is equal to (32,) which is both the *Sum* of the *Extreams*, (4 and 28,) and of the *Means* (12 and 20) Also,

In the four *discontinued Proportionals* 4, 12, 30, 38, it is also as evident, That the first term 4, more by the third term 30, more by once the difference 8, is equal to 42, which is equal to the *Sum* of the *Extreams* (4 and 38,) and also of the *Means* (12 and 32.)

VI. *If there be four Numbers in Proportion, the Number produced of the first and fourth, shall be equal to the Number produced of the second and third. And if the Number produced of the first and fourth, be equal to that produced of the second and third; These Four Numbers shall be Proportional.*

LET the four *Terms* be four *Continual Proportionals*, as these (2, 6, 18, 54.) And let the common *Ratio* be (3.) Then,

The { First } Term is { 2.
 Second } { 2 into 3, (viz. 6.)
 Third } { 2 into the square of 3 (viz. 9.)
 Fourth } { 2 into the Cube of 3 (viz. 27.)

Again, Let the four Numbers be four *Discontinued Proportionals*, as these, 2, 6, 54, 162, and the equal *Ratio* (3.)

The { First } Term is { 2.
 Second } { 2 into the common Ratio 3 (viz. 6.)
 Third } { 54.
 Fourth } { 54 into the common Ratio 3 (viz. 162.)

R E C R E A T I O N S

In the Continual Proportionals it is evident by the Multiplication of Powers :

For the square of the first term 2 (*viz.* 4,) multiplied by the Cube of (3) the common *Ratio* (*viz.* 27,) the Product will be 108, which is equal to 2 the first term, multiplied by 54 the fourth term, and also of 18 by 6, the two mean terms multiplied into each other.

In the four *Discontinued Proportionals* 2, 6, 54, 162, it is also as evident.

For, 2 (the first term) multiplied into 3 (the common *Ratio*) produceth (6,) and that into the third term 54, produceth 324; which is equal, both to the Product of 2 into 162 (the two *Extreams*,) and also of 6 into 54, the two *Means*.

VII. In all Continual Arithmetical Progressions, the Sum of the Extreams is equal to the Sum of any two of the other Means, taken equidistant from the Extreams, and to the double of the middle Term; when the Number of Places be Odd.

LET there be these seven Numbers in *Continual Arithmetical Progression*, *viz.* 3, 6, 9, 12, 15, 18, 21, whose common difference is 3.

First, These four Numbers 3, 6, 18, 21, are four *Proportionals*: Therefore (by the Vth hereof) *The Sum of their Means, and the Sum of their Extreams are equal.*

For the Sum of $\left. \begin{array}{l} 3 \text{ and } 21, \text{ the two Extreams} \\ 6 \text{ and } 18, \text{ the two Means,} \end{array} \right\}$ are equal to 24.

Secondly, These four Numbers 6, 9, 15, 18, are four *Proportionals*; and therefore, *The Sum of their Extreams and Means are equal.*

For the Sum of $\left. \begin{array}{l} 6 \text{ and } 18, \text{ the two Extreams,} \\ 9 \text{ and } 15, \text{ the two Means,} \end{array} \right\}$ is equal to 24.

Thirdly, These three Numbers 9, 12, 15, are three *Proportionals*; and therefore (by the same Vth hereof) *The Sum of the Extreams is equal to the double of the Mean.*

For the Sum of $\left. \begin{array}{l} 9 \text{ and } 15, \text{ the two Extreams,} \\ 12 \text{ and } 12, \text{ the Mean doubled,} \end{array} \right\}$ are equal to 24.

And so $\left. \begin{array}{l} 3 \quad 21 \\ 6 \quad 18 \\ 9 \quad 15 \\ 12 \text{ doubled} \end{array} \right\}$ are all equal one to another, *viz.* 24.

VIII. In Geometrical Proportionals Continual (*how many soever the Places be*) the Product of the Extreams is equal to the Product of any two of the Mean Terms, equidistant from the Extreams, and of the Square of the Middle Term; when the Number of Places be Odd.

LET the Number of Terms be seven, viz. 2, 6, 18, 54, 162, 486, 1458; and their common Ratio 3.

First, These four Numbers 2, 6, 486, 1458, are four Proportionals; and therefore the Product of the two Extreams shall be equal to the Product of the two Means: So

The Product of $\left. \begin{array}{l} 2 \text{ into } 1458, \text{ the Extreams,} \\ 6 \text{ into } 486, \text{ the Means,} \end{array} \right\}$ is equal to 2916.

Secondly, These four Numbers 6, 18, 162, 486, are Proportionals: And

The Product of $\left. \begin{array}{l} 6 \text{ into } 486, \text{ the Extreams,} \\ 18 \text{ into } 162, \text{ the Means,} \end{array} \right\}$ is equal to 2916.

Thirdly, These three Numbers 18, 54, 162, are three Proportionals; and therefore the Product of the two Extreams, is equal to the Square of the Mean. For

The Product of $\left. \begin{array}{l} 18 \text{ into } 162, \text{ the two Extreams,} \\ 54 \text{ into } 54, \text{ the Mean into it self,} \end{array} \right\}$ is equal to 2916.

And so $\left\{ \begin{array}{l} 2 \\ 6 \\ 18 \\ 54 \end{array} \right\}$ into $\left\{ \begin{array}{l} 1458 \\ 486 \\ 162 \end{array} \right\}$ are all equal one to the other, and each of them equal to 2916.

C H A P. V.

Concerning the Rule of Three, or Golden Rule, both Single and Compound.

THIS Rule may (and most properly) be called the Rule of Proportion; for that it teacheth (in any case) by having Three Numbers given, to find a Fourth, which shall be in Proportion to them; And for the Reason of the manner of Working this Rule, the Theorems delivered in the foregoing Chapter will be Subservient.

Now, this Rule is either Single or Compound.

I. Of

R E C R E A T I O N S

I. Of the Single Rule of Three.

The *Single Rule of Three*, is, When *Three Numbers* are Given, and a *Fourth Proportional Number* required. And this Rule is either *Direct*, or *Inverse*, or *Reciprocal*.

I. Of Direct.

The *Single Rule of Three Direct*, is, When *Three Numbers* are given, and a *Fourth* is demanded, which bears the same Proportion to the *Third*, as the *Second* bears to the *First*. —As in this following *Example* :

If 4 Acres of Ground cost 80 l. What will 8 Acres of the like Ground cost ?

For the Better understanding of this Operation, look back to the VIth Section of the foregoing Chapter, where you shall find it demonstrated : That, If there be Four Proportionals, the Product of the First and Fourth, is equal to the Product of the Second and Third.

Wherefore, In this Example,

If the Product of 8 in 80 (the second and third Terms) produce 640; If that 640 be divided by 4, the first term, the Quotient will be 160; and is the fourth Proportional sought.

And for Proof of this,

Let the fourth term found (*viz* 160,) be multiplied by the first term (4,) the Product will be the same with the Product of the second term (80,) multiplied by the third term (8,) namely (640.)

And from hence we may argue thus,

If the Product of (80 by 8) be equal to the Product of (4 by the unknown number)

Then,

The Quotient will be the very same, whether I divide the Product of (80 by 8,) or whether I divide the Product of (4 by the unknown number) by 4. For either of the Products being 640, the Quotient must needs be 160.

And now it is manifest,

That if I multiply 4 by a 160, and divide that Product back again by 4, it will give 160 for the Quotient : Because, Whatsoever *Multiplication* doth, is undone again by *Division*. And this is the true and genuine Reason of the Operation of the Rule of Three.

And that is to say,

As (4) is found in (80) just 20 times; so (8) is found in (160) just 20 times.

Or thus,

As 4 multiplied by 20 makes (80,) so (8) multiplied by (20) makes (160.)

Another Example.

If 80 l. will buy 4 Acres of Land, How many Acres will 160 l. buy ?

If you divide the Product of 4 into 160 (*viz*. 640) by (80,) the Quotient will be (8.) For, as (80) contains (4) 20 times, so (160) being divided by (20,) the Quotient will be (8) also.

2. Inverse,

2. *Inverse, (or Reciprocal.)*

The *Single Rule of Three Inverse*, is, When there are *Three Numbers* given, and a *Fourth* required, which shall bear the same *Proportion* to the *Second*, as the *Third* doth to the *First*.

As in this Example.

If a certain quantity of Pecks of Oats will keep 8 Horses for 12 days; How many days will the same quantity of Pecks keep 16 Horses?

Caution:

The most Authors that have writ of Arithmetick, have made two distinct Rules of this Golden Rule, calling the one *Direct*, and the other *Inverse*; whereas (in truth) they are but One: Only care must be taken how to place the *Terms* given.

So in this Example, Look what *Proportion* 16 Horses bear to 8 Horses; the like *Proportion* do 12 days bear to a fourth number of days: And the *Terms* ought to be thus placed.

As 16 Horses, to 8 Horses; so 12 days to 6 days. And then the Operation is the very same as before: For the *Product* of 8 by 12 is (96,) which being divided by 16, the *Quotient* is (6) days.

II. *Of the Double, or Compound Rule of Three.*

THE *Double, or Compound Rule of Three*, is, When more Numbers than *Three* are given: And it is either *Direct* or *Inverse*.

I. *Direct.*

Example 1. If 4 Men spend 19 Pound in 3 Months; How many Pounds will 8 Men spend in 9 Months?

The Solution is thus performed.

(1.) If 4 Men spend 19 Pound; what will 8 Men spend?

Set the Numbers thus.

Men	Pounds	Men	Pounds
4	19	8	38

For 19 in 8 (the two *Mean Terms*) produce 152, which divided by 4 (the given *Extream*) the *Quotient* is 38 (the other *Extream*.)

(2.) If 38 Pound be spent by any number of Men in 3 Months; How many Pounds will be spent by the same number of Men in 9 Months;

Set the Numbers thus:

Months	Pounds	Months	Pounds
3	38	9	114

For,

R E C R E A T I O N S

For, 38 in 9 (the two *Mean Terms*) produce 342; which divided by 3 (the given *Extream*) the *Quotient* will be 114 (for the other *Extream*.) And so many *Pounds* will 8 *Men* spend in 9 *Months*.

II. Inverse.

Example 2. *If 9 Bushels of Oats will serve 8 Horses for 12 days; How many days will 24 Bushels serve 16 Horses?*

The Solution is thus performed.

1. As 9 Bushels is to 12 days, so is 24 Bushels to 32 days.

Set the Number thus.

Bushels	Days	Bushels	Days
9	12	24	32

For, 12 in 24 (the two *Means*,) produce 288, which divided by 9 (the given *Extream*,) the *Quotient* is 32 (for the other *Extream*.)

2. As 16 Horses is to 8 Horses; so is 32 Days to 16 Days.

Set the Numbers thus.

Horses	Horses	Days	Days
16	8	32	16

For 8 in 32 (the two *Means*;) produce 256, which divided by 16 (the given *Extream*;) the *Quotient* will be 16 for the other *Extream*.

And let this suffice for the *Reason* of the *Operation* of the *Golden Rule*.

C H A P. VI.

Of the Increase of Swine, Corn, Sheep, &c.

I. Of Swine.

Unto what Sum of Money may all the Pigs that One Sow, with all the Pigs of her Race, and the Increase issuing of them, in Twelve Years time, amount unto?

Suppose the Sow brings forth but six Pigs at a Litter, of which we will allow two to be Barrow (which is as little as can be supposed.) And then imagine that every of those four, bring as many every Year; and the increase of them the like, during the Term of twelve Years.

This

This is performed by *Geometrical Progression*, where the common *Ratio* is 4, and the Sum of all the Numbers is 22369620, i. e. *Twenty two Millions, 369 thousand, Six hundred and twenty Pigs.*

Now for the maintenance of these *Pigs*: Suppose *Five shillings* be allowed for to maintain one of these *Pigs* for a *Year*, (which is little enough, for it is not half a *Farthing* a day,) yet there must be 22369620 *Crowns* to maintain them all for one *Year*, which number being divided by 4, the *Quotient* will be 5592405, which is *Five Millions, Five hundred ninety two Thousand, Four hundred and five Pounds Sterling* for one *Year*.

The Increase.	Year.
4	I
16	II
64	III
256	IV
1024	V
4096	VI
16384	VII
65536	VIII
262144	IX
1048576	X
4194304	XI
16777216	XII
22369620	

II. Of Corn.

What quantity of Ground will be capable of receiving one Grain of Corn and the increase of it for eight Years; and to what number of Grains will the increase of that one Grain arise unto.

FOR the first Year, let there be allowed *one quarter of an Inch* of *Ground* to sow the *one Grain* in (which is, indeed, too little), and this *Corn* we will suppose had in the ear, at the *Years* end, 40 *Corns* (for that is but reasonable) then the second *Year* we must allow 40 square quarters of *Inches* of *Ground* to sow those 40 *Corns* in, that is, 10 square inches of *Ground*. And the

third *Year*, supposing those 40 *Corns* to produce 40 *Ears*, and in each *Ear* 40 *Corns*, as before, they will be in the third *Year* increased to 1600 *Corns*; so that there must be 1600 square quarters of *Inches* of *Ground* to sow that Increase in, which is 40 square *Inches*, and thus continuing till the eight *Years* be expired, the Increase would be at the eight *Years* end 16384000000 *Corns*, as in the *Table*, in the *Margin* (where the common

Increase in Corns, and Ground.	Year.
	I
40	II
1600	III
64000	IV
2560000	V
102400000	VI
4096000000	VII
163840000000	VIII
Corns 168041025641	
Inches of Land 42010256410	

Ratio is 40). And the Sum of all the *Corns* in the *Table* do amount unto 168041025641 *Corns*, and consequently so many square quarters of *Inches* of *Land* must be allowed for the sowing of those *Corns* in; one fourth part whereof is 42010256410 square *Inches* of *Land* to sow this increase in, that is, *Forty two Millions of Millions, ten Millions, Two hundred*

dred sixty four Thousand, Four hundred and ten Inches. Now note, That in one Acre of Land, there is contained 6272640 square Inches; wherefore divide the 42010256410 Inches, by 6272640 (the Inches in one Acre) and the Quotient will be 6697 Acres; and so much Land would be required to contain the sowing of the increase of one Corn in eight Years; which if Land were rated but at Five Shillings the Acre for a Year, it would amount to 1674 Pounds Five Shillings a year Rent for the Ground to Sow this one Corns Increase in, in eight years time.

Upon such a Condition, a Country Fellow agrees with a Rich Farmer to serve him for eight Years, he requiring no other Wages, than One Corn, and One quarter of an Inch of Land to Sow it in, for the first Year, and so on for the whole eight Years: Now I do question at the eight Years end which was the Richest Man, the Farmer or his Servant.

III. Of Barley.

Unto what Quantity of Barley will one Corn arise unto, that one Corn being doubled (according to Geometrical Progression) 72 times: Also the Worth of so much Barley in Money: The Weight of so much: How it should be removed: And where stowed.

I. For the Quantity of it.

IF we allow Ten thousand Corns to a Pint (which is more than enough) then 5120000, that is, Five millions, one hundred and twenty thousand Corns will make a Quarter; notwithstanding (for the ease of such as will make trial) we will allow 10000000, Ten millions of Corns to make a Quarter; by which number, if you divide the whole number of Corns, that will arise in the 72 place, being doubled (because we make a Quarter to contain 10000000 Corns; whereas it does contain little more than half so many (viz. 5120000 Corns) and that may be done by cutting off the seven last figures towards the right hand: Then the Quotient of that division will be found to be 472236648286964: And so many whole Quarters of Barley would the number of Corns in the 72 place have amounted to, besides some odd Bushels which we omit.

II. For the Worth of so much Barley.

Suppose it were rated at 15 Pence the Bushel (which is a very low rate) that is 10 Shillings the Quarter, and then it would amount unto 236118324143483 Pounds Sterling; which Sum rendred in words is, Two hundred thirty six millions of millions; One hundred and eighteen, three hundred twenty four millions; One hundred forty three thousand; Four hundred eighty three. — And thus, If you reckon Land for ever worth twenty Years Purchase: If you divide this Sum of Pounds by 20, the Quotient is 11805916207174, that is, Eleven millions of millions, eight hundred and five thousand, nine hundred and sixteen millions, two hundred and seven thousand, one hundred seventy four Pounds a year. And again, If you divide this number of Pounds by 365 (the days in one year) the Quotient

Quotient will be 32344975910, that is, *Thirty two thousand three hundred forty four Millions, nine hundred seventy four Thousand, nine hundred and ten Pounds a day for ever.*

III. *For the Weight of this Barley.*

If we allow eight *Bushels* (or one *Quarter*) to weigh two hundred Weight (but doubtless it weighs more) then the whole number of *Quarters*, viz. 472236648286964, multiplied by 2, gives the *Weight* of all the *Barley* to be 944473296573928 *hundred Weight*. And if you divide this number by 20 (the number of *Hundreds* in one *Tun*) the Quotient will be 47223664828696 *Tuns*, that is, *Forty seven Millions of Millions, two hundred twenty three thousand six hundred sixty four Millions, eight hundred twenty eight Thousand, six hundred ninety six Tuns.*

IV. *For the Stowage of this Barley.*

If we suppose one *Ship* to contain a *Thousand Tun*; then must there be 47223664828, that is, *Forty seven thousand two hundred twenty three Millions, six hundred sixty four thousand, eight hundred twenty eight*, such *Ships* to carry it: And, if there were *four Millions* of *Nations* in the *World*, and every one of those *Nations* had *Ten thousand Sail* of *Ships* of a *Thousand Tun* a-piece, yet all those *Ships* would not contain it. By what is here delivered, you may see how prodigiously *Numbers* do increase by being multiplied according to *Geometrical Progression*.

IV. *Of other Grain.*

Mustard-seed is a *Grain* of very great *Production*; for would one imagine that one *Grain* of *Mustard-seed*, and its Increase for 20 *Years*, cannot be contained within the *Visible World*; nay, if it were 100 times greater than it is, it holding nothing besides, from the *Center* of the *Earth* to the *Firmament*: For proof of which by *Art*, Let us suppose, that one *Grain* of *Mustard-seed* sown, to bring forth a *Tree* or *Branch*, in each extendure of which might be a *Thousand Grains*; but we will suppose only One thousand in the whole *Tree*: And then proceeding to a *Progression* of 20 *Years*, where the common *Ratio* must be 1000, in less than 17 *Years* you shall have so many *Grains* which will surpass the *Sands* which are able to fill the whole *Firmament*: For, according to the *Supposition* of *Archimedes*, and of *Tycho-Brabe*, of the *Greatness* of the *Firmament*; the number of *Grains* of *Sand* to fill that capacity, will be sufficiently expressed by an *Unite* and 49 *Cyphers*: But the number of *Grains* of *Mustard-seed*, at the end of 17 *years*, will be an *Unite* and 52 *Cyphers*; and besides, *Grains* of *Mustard-seed* (though very small) are far greater than grains of *Sand*: It is therefore evident, That at the 17th *years* end, that which shall successively spring from one *Grain* only, cannot be contained within the limits of the whole *Firmament*; what then would it be, if multiplied again by 1000 for the 18th *Year*, and that again by 1000 for every *years* increase till you come to the 20th *year*? It is very evident, that such a heap of *Mustard-seed* would be One hundred thousand times greater than the *Earth*.

V. Of Sheep.

Unto what Sum of Money will 100 Sheep and the Increase of them, being preserved for the space of 16 Years, amount unto?

Suppose a Man at the beginning of the Year were possessed of 100 Sheep, and that every one of them should produce but one Lamb every year, unto what will these 100 with their increase amount to at 16 years end?

Years.	Increase.
I	200
II	400
III	800
IV	1600
V	3200
VI	6400
VII	12800
VIII	25600
IX	51200
X	102400
XI	204800
XII	409600
XIII	819200
XIV	1638400
XV	3276800
XVI	6553600

This is easily resolved by a Geometrical Progression, as in the Margin; wherein you may see, that at the expiration of the 16th year the Sheep will be increased to 6553600, which is, Six Millions, five hundred fifty three Thousand, six hundred Sheep: Which if reckoned but at five Shillings a-piece, it will amount unto 1638400, that is, One Million, six hundred thirty eight Thousand, six hundred Pound.

VI. Of Men.

IT may seem hard to conceive, that from eight Persons which were saved after the Deluge, or Noah's Flood, should spring such a World of People to begin a Monarchy under Nimrod, being but 200 years after the Flood; and that amongst them should be raised an Army consisting of Two hundred thousand Fighting Men: But it is easily proved: For, if we take but one of the Children of Noah, and suppose that a New Generation of People begin at every 30 years, and that it be continued to the seventh Generation, which is 210 years; for then, of one only Family there would be produced 111305, that is, One hundred and eleven thousand, three hundred and five Souls to begin the World; although in that time Men lived longer, and were more capable of Generation, Multiplication and Increase. Now such a Number arising only from a simple Production of only One yearly, would be far Greater, if one Man should have many Wives (as in ancient times they had.) And from hence it is also, that the Children of Israel, who came into Egypt only Seventy Souls, yet after 210 years Captivity, they came forth with their Hosts, so that there was told Six hundred thousand Fighting Men, besides Old People, Women and Children: And he that shall separate but one of the Families of Joseph, it would be sufficient to make up that Number: And how much more would it be then, if many Families were joyned together?

C H A P. VII.

Of Changes in Bells ; in Musical Instruments, &c.

I. *Of Changes in Bells.*

IT. is often disputed among common *Ringers*, what Number of *Changes* may be made in 5, 6, 7, 8, or any other Number of *Bells*.

This and such like *Questions* may be easily resolved ; for it is but multiplying every number from the *Unites* successively into each others *Product*, unto the number of *Unites* assigned ; according to which the following *Table* is made, as is easy to perceive : And so the Number standing against VI in the *Table*, is 720, and so many *Changes* may be made upon *Six Bells* ; 5040 upon *Seven*, &c.

II. *Of Voices.*

If it were required to know how many *Consorts Ten Voices* will make, each man keeping his own *Note*, but altering his *Place* ; against the Number X in the *Table* you find this number 3628800 ; which is *Three millions, six hundred twenty eight thousand, and eight hundred* ; and so many *Consorts* may be made of *Ten Voices*.

It is also the same in *Stringed Instruments* ; and the *Gamauth* may be varied.

I	a	1
II	b	2
III	c	6
IV	d	24
V	e	120
VI	f	720
VII	g	5040
VIII	h	40320
IX	i	362880
X	k	3628800
XI	l	39916800
XII	m	479001600
XIII	n	6227020800
XIV	o	87178291200
XV	p	1307674368000
XVI	q	20922789888000
XVII	r	355687428096000
XVIII	s	6402373705728000
XIX	t	121645100408832000
XX	v	2432901008176640000
XXI	w	51090942171709440000
XXII	x	1124000727777607680000
XXIII	y	25852116738884976640000
XXIV	z	620448401733239439360000

A Table of
CHANGES, &c.

accord.

according to this, answerable to the *Number* standing against XXII, namely, 1124000727777607680000 *Notes*.

III. Of Changes of Places.

Into how many several *Positions* may the Twelve Figures about the *Dial-Plate* of a *Watch* or *Clock-Dial* be placed? The work is easily done, for the *Number* standing against XII in the *Table* will resolve you, viz. 479001600, which is, *Four hundred seventy nine millions, one thousand and six hundred times*. And according to this way there was a pretty *Bargain* made between a *Young Scholar* and a *Country Gentleman*; which is this:

A Young Scholar being come to a *Country Town* where he intended to reside some time, lit into a *Gentleman's House*, where there were in *Family* the *Master, Mistress, and Four Children*, which with himself made *Seven*. At dinner they discoursed concerning the *Scholar's Board* there for a *Year*, for which the *Gentleman* demanded a certain *Sum of Money*; which the *Scholar* thinking too much, made this *Overture*; That he would give him so much for a *Year* as he did demand, provided, That for that same *Money* he should have his *Board* so long time as he could daily place those *Seven Persons* that were then at the *Table*, in a several and distinct *Order*, so that they should never all of them sit in the same *Places* as then they did: The *Gentleman* condescends: The *Question* is, *How many days may the Scholar sojourn with the Gentleman, before all these Changes of Places come about?*

Look in the *Table* for the *Number* standing against VII, and you shall find it to be 5040, so that the *Scholar* (according to this *Agreement*) must sojourn with him *Five thousand and forty days*, which is *Fourteen years wanting 70 days*; and that at *Three-Pence* a day will amount unto *Threescore and three Pounds Sterling*.

IV. Of the Letters of the Alphabet.

From hence it is no marvel, that from the mutability of *Transmutations*, out of the 24 *Letters* of the *Alphabet*, there ariseth and is made such *Variety* of *Languages* as are in the world, and such infinite number of *Words* in each *Language*, seeing the diversity of *Syllables* produceth that effect; and also by the interchanging and placing of *Consonants* among the *Vowels*, and amongst themselves; since this *Alphabet* of XXIV *Letters* may be varied so many times as the *Number* against XXIV amounteth to; viz.

620448401733239439360000.

Which is,

Six hundred and twenty thousand, four hundred forty eight myriads, four hundred and one thousand seven hundred thirty three thousand two hundred thirty nine millions of millions, four hundred thirty nine thousand millions, three hundred and sixty thousand.

Now if from hence we should allow that a man may read or speak *One hundred thousand Words* in an *hour*, which are as many as are contained in all the *Gospels* of the *Four Evangelists*, and in the *Acts* of the *Apostles*

Apostles also, (a Task too great for a man to do in so short a time) and if there were *Four thousand six hundred and fifty thousand millions of men*, they could not speak all the *Words* that the 24 Letters are capable to make (according to the hourly proportion aforesaid) in 70000 *Threescore and ten thousand years*; which number of *Words* if they should be written in *Books*, each *Book* being 15 inches long, 12 broad, and 6 thick, the *Books* made of the aforesaid Transmutation of the 24 Letters, would be 38778037089928788. And if a *Library* of a *Mile Square* every way, of 50 foot high, and in which were 250 *Galleries* of 20 Foot broad apiece, it would contain but *Four hundred millions* of the said *Books*: So that there must be to contain the rest no less than 96945092, *Ninety six millions, nine hundred forty five thousand, ninety two, such Libraries*: And if the *Books* were extended over the superficial surface of the whole *Earth*, it would be a *Decupal Covering* to the same. — And it is from hence that *Tacquet* in the 8th. Chapter of his 5th. *Book of Arithmetick* affirms, That the *Permutation* of 24 Letters are so numerous, that a *Thousand millions* of able *Clerks*, in a *Thousand millions* of years (not sparing *Dominicals* nor *Festivals*) were not able to transcribe them. And *Galdinus* asserts, That the *Books* which might be compiled of the variety of 23 Letters only (accounting 1000 *Pages* to each *Volume*, and 100 *Lines* to each *Page*, and 60 Letters to each *Line*, and not any two *Words* in any of those *Volumes* the same) would do more than twice cover the whole *Superficies* of the *Earth* and *Sea*: Nay farther, he seems to be of opinion, that the *Paper* of those *Volumes* laid singly *Sheet* by *Sheet*, would cover the very *Firmament*.

And as in the *Transposition* of Letters, so also in the *Transposition* of the *Nine Digit Figures*, which with the *Nul.* or *Cypher* makes *Ten*, are capable of 3628800, that is, of *Three millions, six hundred twenty eight thousand, and eight hundred Changes*. And in *Mr. Henry Briggs* his *Logarithms* to 100000, consisting of *Sixty nine Sheets*, in each *Sheet* *Four Pages*, and in each *Page* *Four hundred and fifty numbers*, in all 124200; i. e. *One hundred twenty four thousand and two hundred Numbers*. And in the *Canon* of *Sines Tangents* and *Secants* of the same *Book*, consisting of 22 *Sheets* and a half, in which are *Forty Pages*, and in each *Page* *Three hundred and sixty numbers*; in all 16200; i. e. *Sixteen thousand and two hundred Numbers*, which with those of the *Logarithms*, make together 140400, i. e. *One hundred and forty thousand and four hundred numbers*; and not two *Numbers* exactly the same in both the *Books*: Yet notwithstanding this vast *Number*, it is less than the *Number* against X in the *Table* by 3488400: Nay, it is very little above the *Twenty sixth* part thereof: So that if *Twenty six* such *Books*, all of *Numbers*, and each *Book* to contain *One hundred and forty thousand four hundred numbers*, and not any two *numbers* the same in all the *Books*, they would but contain the number of the *Number* that the *Table* exhibits against X in the *Table*.

C H A P. VIII.

Of Arithmetical Verifying.

Shewing an Artificial way, How from any Six or Five of the Nine Digit Numbers (promiscuously taken, or set down at all adventures), to make both Hexameter and Pentameter Latin Verses, which shall be Good Latin, and Good Sense; altho the Party which writes the Verse from the Six or Five Figures so set down, doth not understand any thing of the Latin Tongue.

The Fundamental S C H E M E.

	1st. Fig.	2d. Fig.	3d. Fig.	4th. Fig.	5th. Fig.	6th. Fig.
1	Perfida	Verba	Vides	Promittunt	Fœdera	Certa
2	Horrida	Jura	Viro	Monstrabunt	Somnia	Multa
3	Turbida	Fata	Tibi	Prædicunt	Pocula	Semper
4	Sordida	Dicta	Scio	Producunt	Dogmata	Sola
5	Candida	Dona	Reor	Casabunt	Crimina	Tantum
6	Turpia	Vota	Malis	Portabunt	Pignora	Quædam
7	Aspera	Facta	Mihi	Confirmant	Jurgia	Prava
8	Tristia	Bella	Inquam	Procurant	Sidera	Sæpe
9	Impia	Damna	Aliis	Concedunt	Tempora	Plana
	3	4	5	2	1	

How to make Hexameter Verses by the Scheme.

Let Six Figures be written by any person, as these 8, 6, 4, 3, 9, 5, or any other.

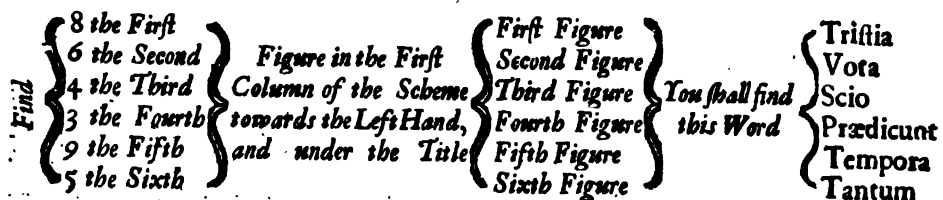

Which Words make this *Latin Hexameter Verse*,

8 6 4 3 9 5
Tristia Vota Scio, Prædicunt Tempora Tantum.

And from any Five Figures collected by the bottom of the Scheme (as these 1, 9, 7, 2, 6,) may be made this or any other *Pentameter Verse*. Example, 1, 9, 7, 2, 6.

1 9 7 2 6
Fœdera Concedunt Aspera Jura Malis.

C H A P.

C H A P. IX.

Of Numerical Enigmatical Problems.

P R O B L. I.

If 136 Pound be to be divided between two persons, so that one must have 18 Pound more than the other; How much must each person have?

From the given Sum (136) subtract (18) the overplus that one person must have above the other, and the Remainder will be (118) the half whereof is (59); and so much must the one person have : And if you add (18) to (59) the Sum will be (77); and so much must the other person have ; for these two numbers (77 and 59) added together, do make up the whole Sum of (136 Pound).

P R O B L. II.

If 136 Pound be to be divided between two persons, in such sort, that the Lesser Share shall have such Proportion to the Greater Share, as 2 half to 5; What must each person have?

FOR the Working of this or the like Question, this is the R U L E, or Analogy.

As the Sum of the two Proportional terms 2 and 5, (*viz.* 7.)
Is to the Sum given to be divided (*viz.* 136.)
So is (2) the Lesser of the Proportional Terms given,
To ($38\frac{6}{7}$) the Lesser Share: And so is (5) the Greater Proportional Number given, To ($97\frac{1}{7}$) the Greater Share.

So if you multiply the given Number (136) by (2) the Lesser Proportional, the Product will be (272) which being divided by the Sum of the Proportionals (7), the Quotient will be ($38\frac{6}{7}$), which is the Lesser Share. — Or if you multiply the given number (136) by (5) the Greater Proportional, the Product will be (680), which divided by (7), the Quotient will be ($97\frac{1}{7}$), for the Greater Share ; and these two ($38\frac{6}{7}$ and $97\frac{1}{7}$) added together, do make (136), equal to the Number given to be divided.

P R O B L. III.

There is a certain number of Pounds to be distributed among Six persons, in such sort that each person from the first shall have 7 Pounds more than the other, and at the end the last person had just as many Pounds more as the first: What was the Sum of Money, and how much had each person?

LET the Six persons be represented by these Six Letters, A B C D
E F ; then suppose that the first person A had 3 Pounds, then B
E must

R E C R E A T I O N S

A	3	35
B	10	42
C	17	49
D	24	56
E	31	63
F	38	70
		35 315

must have 10, C 17, D 24, E 31, and F 38; as in the Margent: But (by the tenure of the Problem) the share of F should be but just double to that of A, but it is much more; wherefore subtract A's share 3, from F's share, 38, and the remainder will be 35; which is the number of Pounds that A must have; and then B must have 7 more (*viz.* 42.) and C 49, D 56, E 63, and F 70, which is just double to what A had; which answers the Question as to that part: Then, these

shares added together, do make 315 Pound, and that was the number of Pounds to be divided.

P R O B L. IV.

There were Five Bags of Money, and in the biggest Bag there was as many more Pounds as there was in the least, and in the middle Bag there was half as much as there was in the biggest and least together; and each Bag from the least had in it 30 Pound more than the other: What number of Pounds was in each Bag?

LET the Five Bags be represented by these Five Letters, G H K L and M, and suppose there was in the least Bag G 4 Pound, then

G	4	120
H	34	150
K	64	180
L	94	210
M	124	240
		120 900

must there be in the Bag H 34, and in K 64, and in L 94, and in M 124. But the Bag M holds much more than double that of G, wherefore subtract G 4, from M 124, and there will remain 120, and so much Money must be in the least Bag G, as in the Margent: Then (because every Bag exceeds other by 30 Pound), there must be in H 150 Pound, in K 180 Pound, in L 210 Pound, and in M 240: And then

M is double to G, for 120 doubled is 240, equal to M, and G and M together is equal to 360, the half whereof is 180, and so much is there in the middle Bag K; and the Money in all the Bags is equal to 900 Pounds: And so is the Question answered in all particulars.

P R O B L. V.

If 136 Pound be to be divided into two parts between A and B, so that B shall have 25 Pound more than A, what is each share?

FROM 136 (the Sum) subtract 25 (the excess that B must have more than A), and the remainder will be 111, the half whereof is 55 l. 10 s. for A; and that added to 25 the excess, it makes 80 l. 10 s. for B; for 55 l. 10 s. and 80 l. 10 s. is equal to the Sum 136 l.

PROBL.

P R O B L. VI.

If 560 Pound be to be divided between A and B, in such proportion as 2 Pound hath to 7 Pound, what must each have ?

THE Sum of the two Proportional Terms 2 and 5 make 7 ; wherefore by the Golden Rule,

As 7 is to 560, so is 2 the lesser Proportional to 160 the lesser Share ; and so is 5 the greater Proportional to 400 the greater Share ; which together make 560 Pound, the Sum to be divided.

P R O B L. VII.

There was a May-Pole which consisted of three pieces of Timber, of which the first (or lowermost) was 13 foot long, the third (or uppermost piece) was as long as the lowermost piece, and half the middle piece ; and the middle piece was as long as the uppermost and lowermost together : How high was this May-Pole, and how long each Piece ?

Multiply the length of the first piece 13, by 3 and by 4, so shall the two Products be 39 and 52, for 13 by 3, is 39 for the length of the uppermost piece ; and 13 by 4, is 52 for the length of the middle piece, which 52 is equal to 13 the lower piece, and 39 the upper piece added together ; and the height of the May-Pole was therefore 104 Foot.

P R O B L. VIII.

A Grandfather living in the house with his Son, and his Son's Wife, and their Three Sons, and discoursing concerning their Ages, the Father said, I am as old as my Wife and Second Son, and four years over. — The Wife said that she was as old as all her three Sons, and three years over. — The Eldest Son said that he was as old as his two younger Brothers, and 3 years over. — And the Second Son said he was four times the age of his younger brother, and one year over. And when all their Ages were added together, they proved to be the just Age of the Grandfather, who was then 125 years old. What was the age of the Father, Mother, and all the three Sons ?

FOR the resolving of this and the like Questions, suppose the youngest Son to be One year old, then the second must be 4 years, and 1 over, and the eldest as old as both the other, that is, 5 years, and 3 over. Also the Mother must be as old as all the three Sons, which is 10 years, and 3 over : And consequently by the Tenor of the Question, the Father being the Age of his Wife and Second Son, must be 14 years old, and 4 over.

Which set down in this manner,

The Youngest Son was old	1 Year.
The Second Son was then	4 Years, and 1 over.
The Eldest Son was then	5 Years, and 3 over.
The Mother then must be	10 Years, and 3 over.
The Father must then be	14 Years, and 4 over.

All which added together make 34 Years, and 11 over.

E 2

But

R E C R E A T I O N S

But according to the tenor of the *Question*, all their Ages together should be equal to the Age of the *Grandfather*, which was 125 years: Wherefore, to find the Age of the *youngest Son*, you must work by the Rule of Proportion thus: Saying,

As 34 years
Is to 1 year (the supposed Age of the *youngest Son*)
So is 125 years (the Age of the *Grandfather*.)
To $3\frac{12}{34}$, or in Decimals thus, 3. 352 years,
For the Age of the *youngest Son*.

And then

The Youngest Son	3. 352				
The Second Son	13. 408 and	1 over,	}	that is,	3. 352
The Eldest Son	16. 760 and	3 over,			14. 408
The Mother	33. 520 and	3 over,			19. 760
The Father	46. 928 and	4 over,			36. 520
					50. 928

113. 968 and 11 over (that is) 124. 968

The Sum here is 113. 968 years, to which the 11 years over being added in their due places, as in the second part of the Example they are, the Sum will be 124. 968 years, equal to the Age of the *Grandfather*; and the *Question* resolved in every particular.

P R O B L. IX.

If 222 Crowns be to be divided among three Persons A B and C, in such proportion that C shall have 9 times as many as B, and 6 times as many as A wanting Ten.— And B shall have 7 times as many as A, and 25 over: How many Crowns must A have, and also B and C?

Suppose A to have only one Crown, then by the *Question*, B must have 7 Crowns, and 25 over; and C must have 9 times as many as B, that is 63, and 6 times as many as A, that is 6, in all 69 wanting 10; which set in this manner.

A	1 Crown.
B	7 Crowns, and more 25.
C	69 Crowns wanting 10.

The Sum 77 Crowns, more 25, wanting 10.

Subtract the 10 wanting from the 25 more, and then there will remain 15 over; Subtract 15 from 222, and there will remain 207, for a dividend, and the Sum 77 must be the divisor; wherefore divide 207 by 77, and the Quotient will be $2\frac{52}{77}$ (or in Decimals 2. 688) for the

A having	2. 688.
B must have	18. 816 and more 25.
C must have	185. 472 wanting 10.

The Sum 206. 976.

share of A, and then A having 2. 688, B must have 7 times as many, that is 18. 816, and 25 over; and C must have nine times as many as B, which is 169. 344, and six times as many as A, which is 16. 128, which together

together makes 185. 472, wanting 10; all which being added together as above, do make 206. 976, to which the 25 over being added, and the 10 wanting substracted in their due places, the Sum will be 221. 976, that is, 222 Crowns, and answers the Question.

$$\begin{array}{r}
 A \quad 2.688, \\
 B \quad 18.816 \text{ more } 25, \\
 C \quad 185.472 \text{ wanting } 10, \\
 \hline
 206.976 \text{ more } 25 \text{ want } 10.
 \end{array}
 \left. \vphantom{\begin{array}{r} A \\ B \\ C \end{array}} \right\} \text{that is, } \left\{ \begin{array}{r} 2.688. \\ 43.816. \\ 175.472. \\ \hline 221.976.
 \end{array} \right.$$

P R O B L. X.

There are four Weights A B C D, all which together do weigh 324½ Pound, of which B weighs more than A by 9 Pound, C weighs three times as much as A, and four times as much as B; and D weighs 6 times A, 3 times B, and once and a half C; their respective weights are demanded.

LET the weight A be supposed to weigh only one Pound, then B must weigh 1 Pound and 9 over; and C must weigh 3 times A which is 3, and 4 times as much as B which is 4, which together make 7 for C; and then D must weigh 6 times A, 3 times B, once and a half C, and 4 times B, which together make 19½; all which added together do make 28½ more by 9, which should be equal to 324½; Subtract the 9 which is over, from 324½, and the remainder will be 315½ for a Dividend, and the Sum 28½ is the Divisor: Divide 315½ by 28½ (or decimally 315.5. by 28. (5) the Quotient will be 11.07 for the weight of A. Then

$$\begin{array}{r}
 A \quad 1. \\
 B \quad 1 \text{ more } 9. \\
 C \quad 7. \\
 D \quad 19\frac{1}{2}. \\
 \hline
 \text{Sum } 28\frac{1}{2} \text{ more } 9.
 \end{array}$$

$$\begin{array}{r}
 A \text{ weighing } 11.07, \\
 B \text{ must weigh } 11.07 + 9, \\
 C \text{ must weigh } 77.49, \\
 D \text{ must weigh } 215.86, \\
 \hline
 \end{array}
 \left. \vphantom{\begin{array}{r} A \\ B \\ C \\ D \end{array}} \right\} \text{or } \left\{ \begin{array}{r} 11.07 \\ 20.07 \\ 77.49 \\ 215.86 \\ \hline
 \end{array} \right.$$

Their Sum 315.49 + 9, or 324.49 which answers the Question.

P R O B L. XI.

Three Merchants build a Ship which cost 6000 Pound, of which A paid ¼ part, B ⅓ part, and C ½ part; What did each pay?

Multiply the Denominators of the several Fractions ¼, ⅓, and ½, and they make 120; divide this 120 by each several Denominator, as by 4, by 5 and by 6, and the Quotients will be 30, 24 and 20,

$$\text{For } 120 \text{ divided by } \left\{ \begin{array}{l} 4 \\ 5 \\ 6 \end{array} \right\} \text{ giveth for its Quotient } \left\{ \begin{array}{l} 30 \\ 24 \\ 20 \\ \hline
 \end{array} \right.$$

The Sum whereof is 74

Then

R E C R E A T I O N S

Then say by the Golden Rule of Proportion,

$$\begin{array}{r} \text{If } 74 \text{ come of } 6000, \left. \begin{array}{l} 30 \\ 24 \\ 20 \end{array} \right\} \text{Answer} \left\{ \begin{array}{l} \text{A } 2432.43 \\ \text{B } 1945.95 \\ \text{C } 1621.62 \end{array} \right. \\ \text{what will come of} \end{array}$$

$$\text{The Sum} \text{---} 6000.00$$

P R O B L. XII.

There are three Weights ABC, of which, the least Weight A, weighs 30 Pound, and the other two together do weigh seven times as much as A, and they are in proportion one to the other as 4 is to 5.

THE Weight A weighing 30 Pound, the other two Weights together weighing 7 times A which is 30, must weigh 210 Pounds; and the Proportional Numbers 4 and 5 being added together do make 9. Then by the Rule of Proportion :

As 9, the Sum of the Proportional terms
Is to 210 the Sum of the two unknown Weights;
So is 5, the Greater Proportional Number,
To the Weight of the Greater Weight.

Wherefore, Multiply 210 by 5, the Product will be 1050, which divided by 9, gives in the Quotient 116 $\frac{2}{3}$ for the Weight of the bigger Weight; and that subtracted from 210, the remainder is 93 $\frac{1}{3}$, for the lesser Weight, and so the three Weights are

$$\begin{array}{r} \text{A } 30 \\ \text{B } 93 \frac{1}{3} \\ \text{C } 116 \frac{2}{3} \end{array} \left. \right\} 240 \text{ the Weight of all three.}$$

P R O B L. XIII.

Two Travellers set out from two Towns which are 140 Miles distant, upon one and the same day; One travels 8 miles a day, the other 6: In how many days Travel will they meet each other?

SUPPOSE one D (or Day) for the time that they shall meet, in which time one would have travelled 8, and the other but 6 miles of the Journey, which together make 14 miles; whereas they should have been 140 miles: Wherefore, divide 140 by 14, the Quotient will be 10, and in so many days will they meet: For 10 times 8 is 80 Miles; and 10 times 6 is 60 Miles; which together make 140 Miles the whole Journey.

PROBL.

P R O B L. XIV.

There is a Cistern which hath Four Cocks of several Sifes, which Cistern holds 8 Barrels of Water? If the first or least Cock be opened, the Water will be 6 hours in running out: If the second Cock be only opened, the Water will issue out in 4 hours: If the third be only opened, it will run out in 3 hours; and if the fourth and biggest be only opened, it will run out in 2 hours: In what time will it run out, if all the four Cocks be set running together?

IF the least Cock will vent 8 Barrels (that is, all the Water) in 6 hours, the second would vent 12 Barrels in that time, the third 16, and the fourth 24 Barrels, in all 60 Barrels.

Here is now a Proportion between 60 Barrels and 8 Barrels, and between 6 hours and the time that all the Water will be vented in, if all the Cocks were opened: Wherefore say,

If 60 Barrels will run out in 6 hours; In what time will 8 Barrels run out?

Multiply 6 by 8, the Product is 48, which should be divided by 60, but being it is less, the Quotient will be $\frac{48}{60}$ parts of an hour, or 48 Minutes, and in such time will all the Water run out, if all the four Cocks be set open.

P R O B L. XV.

A Man dies, and leaves his Wife big of her first Child; and by Will bequeaths his Estate in manner following: That if the Child his Wife then went withall should prove a Daughter, then his Wife should have two Thirds, and the Daughter one Third of his Estate: If it should be a Son, then the Son was to have two Thirds, and the Mother one Third of his Estate, which Estate was 2600 Pound.—After the decease of the Father, the Mother was delivered of two Sons and one Daughter. How must the Estate be divided amongst them, according to the Will of the Father?

BY the Testators Will it is evident that for one Third that the Daughter had, the Mother was to have two Thirds; and the Son was to have double to the Mother. Then

		l.	s.	d.			
Suppose the	{	Daughter	}	to have	{	1—0—0	}
		Mother				2—0—0	
		1 Son				4—0—0	
		2 Son				4—0—0	
						11—0—0	
		The Sum					

This 11 Pound should be equivalent to 2600 Pound, wherefore divide 2600 by 11, and the Quotient will be 236 l. 7 s. 3 d. 1 q. for the Daughters share: And then will

The

R E C R E A T I O N S

		l.	s.	d.	q.	
The	}	Daughters	236	07	3	1
		Mothers	472	14	6	2
		1 Sons	945	09	1	0
		2 Sons	945	09	1	1
		In all				2600—00—0—0

Equal to the whole Estate.

P R O B L. XVI.

If there be 160 Pound (or 38400 Pence) to be distributed among an equal number of Poor Prisoners, Lame Men, Widows and Children, so that every Prisoner shall have a Shilling, every Lame Man Six Pence, every Woman Four Pence, and every Child Three Pence: How many of such People will this Money relieve?

THE Sum of Pence in 160 Pound being 38400, set that down for a Dividend; then add 12 d, 6 d, 4 d, 3 d together, and they make 25, by which divide 38400, and the Quotient will be 1536; and so many Persons must there be of each kind: For

		l.	s.	d.					
1536	}	Shillings	76	16	0	}	for	{	Prisoners.
		Sixpences	38	08	0				Lame Men.
		Groats	25	12	0				Women.
		Threepences	19	04	0				Children.
		In all				160—00—0			

And now if you multiply 1536 by 4, the Product will be 6144, and so many will be the whole number of Persons to be relieved.

P R O B L. XVII.

What Number is that, which if you divide it by 9 there shall remain 8, divide it by 8 there shall remain 7, divide it by 7 there shall remain 6, and so by 6, 5, 4, 3 and 2, and being divided by 2 there shall remain One?

THere are several such Numbers to be found, and to find the least that is thus qualified, do thus, — Set down all the nine Digits orderly one under another, and against 1 set a Cypher; then under 1 set 2, and add 2 and 1 together, they make 3, which set against 2; then say 3 times 3 is 9, and 2 over 3 is 11, set 11 against 3, and say 4 times 11 is 44, and 3 over 4 is 47, set 47 against 4, and thus continuing you shall find 725759 to stand against 9, and that is the least number that is capable to be divided as abovesaid, for the remainder shall be always a Unite less than the number you divided by.

1	0
2	3
3	11
4	47
5	239
6	1439
7	10079
8	80639
9	725759

2519
5039
7559
10079
12599
15119
17639
20159

There are infinite other Numbers which have the like property, some of which are here inserted. For,

If any of those Numbers be divided by	$\left. \begin{array}{c} 2 \\ 3 \\ 4 \\ 5 \\ 6 \\ 7 \\ 8 \\ 9 \end{array} \right\}$	There will remain	$\left. \begin{array}{c} 1 \\ 2 \\ 3 \\ 4 \\ 5 \\ 6 \\ 7 \\ 8 \end{array} \right\}$
------------------------------------------	-------------------------------------------------------------------------------------	----------------------	-------------------------------------------------------------------------------------

C H A P. X.

Of Numbers thought upon.

IF any Number be doubled, and that doubled be multiplied by 5, the Product of that Multiplication shall be the same with the Number first doubled, cutting off the Cypher which will always be on the Right hand: So 472 being doubled, makes 944, which multiplied by 5, produceth 4720, from which the Cypher being cut off there will remain the first Number 472. — And from hence it is usual to bid one think any Number, then bid him double his number thought, and then multiply that double by 5, and give you the Product, which will be the very number he thought, with a Cypher before it; which omitted, you tell him what number he thought: But this way is so plain and obvious, that any one will discover it: I shall therefore shew some other ways not so liable to discovery.

First Way.

BID him which thinketh double his number thought, unto that double add 4, and multiply that Sum by 5, and unto that Product bid him add 12; then bid him tell you this last Product, unto which do you privately add a Cypher, and from the Sum subtract 320, the remainder (two Cyphers being cut off) will be the number thought.

F

Example.

R E C R E A T I O N S

Example.

The Number thought upon	_____	365
The double thereof	_____	730
To which add 4, it makes	_____	734
That multiplied by 5, makes	_____	3670
To which add 12, it makes	_____	3682

This last Product 3682 being given you, add unto it a Cypher, and it makes 36820, from which subtract (always) 320, and the remainder will be 36500, from which the two Cyphers being taken, there will be left 365, the Number thought.

The Second Way.

B ID the Party that thinketh, break his number into any two parts; then bid him multiply each of those parts by themselves, and also the parts one by the other twice; then bid him add all those four Products together, and give you the Sum of them; from which Sum do you Extract the Square Root, and that Root shall be the number thought.

Example.

Let the Number thought upon be 365; which let be broken into these two parts 221 and 144, which together make 365.

Multiply 221 by 221, the Product is	48841
Multiply 144 by 144, the Product is	20736
Multiply 221 by 144, the Product is	31824
The same again	31824

The Sum of the four Products 133225

The Square Root whereof is 365, the Number first thought upon.

A Third Way.

L E T any Person think (and set down) what Number he pleaseth; then bid him multiply that Number, and their Products successively by all the nine Digits; then bid him give you the last Product; which Product, if you divide it by 362880, the Quotient shall be the Number thought.

So if the Number thought (or set down) were 321, that Number multiplied by One (1) produceth only 321:

And	{	321	Multiplied	{	2	} Produceth	642
		642			3		1926
		1926			4		7704
		7704			5		38520
		38520			6		231120
		231120			7		1617840
		1617840			8		12942720
		12942720			9		116484480

Now

Now if you divide this last Product 116484480 (in any case) by 362880, the Quotient will be 321, equal to the Number thought.

A Fourth Way.

LET any Person think (or set down) any Number, then let him multiply that Number by all the nine Digits; then let him add all the Products together, and give you the Sum of all the Products so added together; which Sum, if you divide (in any case) by 45, the Quotient will be the number thought. So

Let the Number	1	} Producteth	26
thought be 26.	2		52
That Multiplied	3		78
by	4		104
	5		130
	6		156
	7		182
	8		208
	9		234
The Sum 45			The Sum 1170

Which Sum 1170 being divided by 45 (the Sum of the nine Digits) the Quotient will be 26, the Number thought.

A Fifth Way.

BID a Person think (or set down) any Number, then bid him multiply the same Number by any other Number, what he pleases, (telling you what Number he multiplies by.) Then let him multiply that Product by what other Number he pleases (telling you what he multiplies by, as before.) And so continue multiplying three, four, or as many times as he pleases: In the mean time do you set down the Number by which he first multiplied, and multiply that Number by the second Number that he multiplied by, and that Product by what he multiplied by the third time, and as many times as he multiplies; and when he hath done, bid him give you his last Product, which if you divide by your last Product, the Quotient will be the Number which he thought upon.

Example.

Suppose the Number thought upon be 36, which he first Multiplies by 7, and the Product is 252, which he again will multiply by 3, and the Product is 756; which again he will multiply by 9, and the Product will be 6804; which last Product when he hath given you, then privately set down 7 (the Number that he first multiplied by) and multiply it by 3. (the second Number he multiplied by) and the Product will be 21, which multiply by 9 (the third and last Number he multiplied by) and the Product will be 189, by which, if you divide his last Product 6804, the Quotient will be 36, the Number thought upon.

R E C R E A T I O N S

Otherwise,

If you bid him add all his Products together in one Sum, and give you the Sum of them, then do you add all your Products together, and by that divide his Sum, the Quotient will give the Number thought. So

His	}	First Second Third	Product was	$\begin{array}{r} 252 \\ 756 \\ 6804 \\ \hline \end{array}$	Your	}	First Second Third	Product was	$\begin{array}{r} 7 \\ 21 \\ 189 \\ \hline \end{array}$
			The Sum	7812					217

Now if you divide 7812 (his Product) by 217 (your Product), the Quotient will be 36, as before.

VI. If several persons, three, four, five, &c. should each of them think upon a several Number (under Ten), to tell what Number each person thought upon.

B ID the first person double the Number he thought, and add 5 to it, which Sum multiply by 5, and to it add 10; if from this Number you privately subtract (always) 35, the first figure of this remainder towards the left hand, shall be the Number that the first Party thought upon.

Example,

Let one person think	9
The double thereof is	18
To which add 5, it makes	23
This 23 multiplied by 5, makes	115
To which add 10, it makes	125
From which 125, subtract	35
And the remainder is 90; from which the Cypher towards the right hand being omitted, the remainder is 9, the number thought.	9

Thus may you do if *One* person only think a number; but if *Two, Three,* or *Four* persons think severally, it will be much the same.

Example,

Suppose there were three persons, A, B, and C, and each of them should think these three numbers, A 4, B 9, and C 6.

The Number which A thought is	4
Which doubled, makes	8
To which 5 added, it makes	13
Which multiplied by 5, produceth	65
To which add 10, and it makes	75
To this Product bid B privately add the Number he thought	9
It makes	84
Which bid him multiply by 10, it makes	840
To this Product let C privately add his Number thought, viz.	6
It makes	846
Which multiplied by 10, produceth	8460

This

This being done, bid them give you this last Product 8460, from which do you privately subtract 3500, and there will remain 4960; the Cypher being omitted, there will remain these three Digits, 4, 9, and 6, for the Numbers that A B and C severally thought upon.

Note, That if one person only Think, then (as before) subtract from the last Product only 35; if two persons, subtract 350; if three, 3500, &c.

VII. There lies in a heap 132 (or any other number which you know) of Counters, or other Pieces of Money, or any other things whatsoever: Then if Three persons take each of them a certain number of Pieces out of the heap, unknown to you, to know how many Pieces each party took.

LET the number of Counters in the heap be 132, and let the three persons be A, B, and C: Bid one of the Parties, as A, take from the heap 4, 8, 12, 16, 32, &c. or any other number that may be divided by 4, and keep them in his hand: Then bid B for every four Pieces that A took, let him take 7 Pieces: And bid C for every four Pieces that A took, take 13 Pieces: Which when they have done, tell what number of Counters are left, and subtract them from the Number you laid down, and the remainder will be the Sum of Counters which all of them have in their hands, which number do you privately divide by 3, the Quotient shall be double to the Number which A took.

Example,

Let the Number of Counters which you laid down be 132. Then suppose that A took out 16, that is, four times 4, then B must take out 7 for every four that A took, which is four times 7, or 28; and C must take out 13 for every four that A took, and that is 4 times 13, or 52. This done, tell how many Counters there are left upon the Table, which you find to be 36; this subtracted from the whole heap, which was 132, there will remain 96; and so many Pieces have A B and C in their hands; this Number 96 divide by 3, and the Quotient will be 32, the half of which is 16, and so many Pieces did A take; then B must have taken 28, and C 52.

VIII. If there be two Pieces of Money, as a Ninepence and a Shilling, or any other two Pieces (provided one be Even, and the other Odd), let any person take one of them in one hand, and the other in his other hand, to tell in which hand the Ninepence (or Odd Piece) is, and in which the Shilling (or Even Piece) is.

BID the Party that he double the Piece that he hath in his Left hand, and triple the Piece which he hath in his Right hand; then bid him add the two Numbers together, and ask him whether it be Even or Odd; if it be Even, the Shilling is in the Right hand; but if it be Odd, the Ninepence is in the Right hand.

Or,

If you bid the Party double the Piece which he hath in his Right hand, and triple that which he hath in his Left, and if the Number be Even, the Odd Piece is in the Right hand, and the Even in the Left.

IX. *If*

IX. If any Number of Counters (suppose 9) or other Pieces of Money, Stones, or the like, be laid in a Row, to tell what Number (not exceeding the number of Pieces) any one thinketh upon.

LAY Nine Counters on a row, (as in the Figure.)

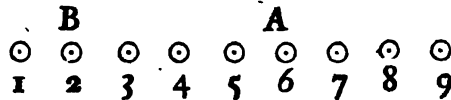

Then do you (privately) call that which lieth next your Left hand One, the next Two, the next Three, &c. then that towards your Right hand will be 9. Then bid any person think any number, not exceeding Nine, and then bid him lay his finger upon any of the Pieces; then (you knowing privately which Piece it is, whether the first, second, third, or any other) add 9 privately to the Number of the Piece he laid his finger upon.

Thus if the Party should think 2, and he should lay his finger upon the Counter A, which is the sixth, to this 6 add 9 (the Number of Pieces in all) and it makes 15; then bid the Party count from the Number which he thought upon (beginning at the Counter A) backwards, till he make his number thought on 15, which Number 15 will end at the Counter B, which is the second Counter, and denotes the Number he thought on, to be 2.

The like may be done with any Number more or less than 9; only remember, that as now you added 9, you must always add the Number of the Counters or Pieces you laid down, whether 6, 10, 15, &c.

C H A P. XI.

A Plain and Easie Method of Extracting the Square Root of any Number (how great soever) without the help of Multiplication or Division.

THIS Method of *Extracting* of the *Square Root*, I cannot but attribute to Sir *Sam. Moreland*, Baronet, altho it doth not much differ from the manner of *Extraction* by *Nepier's Bones*: For as those *Rods* which my Lord *Nepier* (the Inventor of them) calls *Rabdologia*, Sir *Samuel* doth reduce the Position of them into several *Tables*, which he calls *Tariffa's*. The manner of making or preparing whereof I shall here shew:

How

How to make a Tariffa for One or more Figures, that is, for any Digit, or mixt Number.

Example: Suppose I would make a *Tariffa* for the Digit Number 4. As in Table (or *Tariffa*) I.

First, Set down the *Nine Digits* orderly, in a Column towards the left hand, and in Figures bigger than ordinary, that they may take up the space of two lines of smaller Figures.

Secondly, Against the Digit 1, more to the right hand, and at the top or upper part of the line set 4, the Figure for which the *Tariffa* is to be made.

Thirdly, Double 4, and it makes 8, which set under 4, against the Digit 2, and at the upper part of the Line.

Fourthly, Add 4 to 8, and they make 12, which set against the Digit 3: Also to 12 add 4, it makes 16, which set against the Digit 4; to which add 4, and it makes 20, which set against the Digit 5, and so continually adding 4, you shall have 36 to stand against the Digit 9; for 4 times 9 is 36.

Fifthly, In a Column yet one place forward towards the Right hand, set the *Squares* of the several *Digits*; as against 1 set 1, against 2 set 4, against 3 set 9, against 4 set 16, and against 9 you will have 81: And thus is your *First Tariffa* for the single Figure 4 finished.

Now to make a *Tariffa* for two or more Figures, the same method is still to be observed. As for

Example: Suppose I would make a *Tariffa* for 46.

First, In a Column towards the Left hand set down the *Nine Digits* orderly, and in a bigger Figure.

Secondly, Set your Number to be *Tariffed* 46, against 1, as in the second *Tariffa*.

Thirdly, Double 46, and it makes 92, which set against 2; then add 92 to 46, and they make 138, which set against 3; and so by the continual addition of 46, you shall find 414 to stand against the Digit 9, for 9 times 46 is 414.

Lastly, In a Column yet more to the Right hand, set the *Squares* of the *Nine Digits*; as against 1 set 1; against 2 set 4; against 3 set 9; against 4 set 16, as in the first *Tariffa*.

And in the same manner may you make a *Tariffa* for any number, how great soever by the directions of the two foregoing *Examples*; and as is done for the number 468 in the *Third Tariffa*; and for 4684 in *Fourth Tariffa*; &c.

Digits.	First Tariffa.	Squares of the Digits.	Digits.	Second Tariffa.	Squares of the Digits.	Digits.	Third Tariffa.	Squares of the Digits.	Digits.	Fourth Tariffa.	Squares of the Digits.
1	1	1	1	1	1	1	1	1	1	1	1
2	4	4	2	4	4	2	4	4	2	4	4
3	9	9	3	9	9	3	9	9	3	9	9
4	16	16	4	16	16	4	16	16	4	16	16
5	25	25	5	25	25	5	25	25	5	25	25
6	36	36	6	36	36	6	36	36	6	36	36
7	49	49	7	49	49	7	49	49	7	49	49
8	64	64	8	64	64	8	64	64	8	64	64
9	81	81	9	81	81	9	81	81	9	81	81

How to Extract the Square Root of any Number.

LET 548777476 be a Number given, and let the Square Root thereof be required.

First set down the Number, and make a Prick over the first figure thereof towards the right hand, and so over every second figure, as is usual in Vulgar *Arithmetick*, and then will the Number given being so Pointed, stand thus,

$$5 \overset{\cdot}{4} 8 \overset{\cdot}{7} 7 \overset{\cdot}{7} 4 \overset{\cdot}{7} 6$$

And there being five Points, it shews that the *Root* thereof will consist of *Five Figures*, whereof to begin your *Extraction*, find the nearest *Square Number* to 5, the figure under the last Point, and that is 4, the *Root* whereof is 2, put 2 into the *Quotient*, and set the *Square* thereof 4, under 5, and subtracting 4 from 5, there will remain 1, to which 1 bring down the two figures belonging to the *Second Point*, namely 4 and 8, and then it will be 148, and the work will stand thus,

$$\begin{array}{r}
 5 \overset{\cdot}{4} 8 \overset{\cdot}{7} 7 \overset{\cdot}{7} 4 \overset{\cdot}{7} 6 \quad (2 \\
 \underline{4} \\
 148
 \end{array}$$

Then double 2, the figure in the *Quotient*, and it makes 4; for which figure 4 make a *Tariffa*, as is before taught, (as the *First Tariffa* is) and in

in that *Tariffa* find the nearest number to 148, which is lesser, and you shall find that number to be 129, against which (in the Colume of *Digits*) stands 3, put 3 in the *Quotient*, and subtract 129 from 148, and the Remainder will be 19 ; to which bring down the two figures belonging to the Third Point, namely 77, and then the Number will be 1977, and the work will stand thus,

$$\begin{array}{r}
 548777476 \quad (23 \\
 4 \\
 \hline
 148 \\
 129 \\
 \hline
 1977
 \end{array}$$

Then double the two figures in the *Quotient*, and they make 46, for which number 46 make a *Tariffa* (as is the *Second Tariffa* beforegoing) ; and in that *Tariffa* find the nearest number less than 1977, which you will there find to be 1856, against which stands the *Digit* 4; put 4 in the *Quotient*, and subtract 1856 from 1977, and the Remainder will be 121, to which bring down the two figures belonging to the fourth Point, namely 74, and then the Number will be 12174, and the work will stand thus,

$$\begin{array}{r}
 548777476 \quad (234 \\
 4 \\
 \hline
 148 \\
 129 \\
 \hline
 1977 \\
 1856 \\
 \hline
 12174
 \end{array}$$

Then double the three Figures in the *Quotient*, and they make 468 ; for which Number make a *Tariffa* (as is the *Third Tariffa* beforegoing), and in that *Tariffa* find the nearest Number, which is lesser, to 12174, which I find there to be 9364, against which stands the *Digit* 2 ; put 2 in the *Quotient*, and subtract 9364 from 12174, and the Remainder will be 2810, to which bring down the two figures belonging to the last Point, namely 76, and then the number will be 281076, and then the work will stand thus,

$$\begin{array}{r}
 548777476 \quad (2342 \\
 4 \\
 \hline
 148 \\
 129 \\
 \hline
 1977 \\
 1856 \\
 \hline
 12174 \\
 9364 \\
 \hline
 281076
 \end{array}$$

This done, Double the four figures in the *Quotient*, and they make 4684, for which number make a *Tariffa*, as is the *Fourth*, in the foregoing *Examples* ; and in it find the nearest number to 281076, and in it you shall find the very number to stand against the *Digit* 6 : Wherefore put 6 in the *Quotient*, and subtract 281076, from 281076, and there will remain nothing ; which shews that the given number 548777476 is an exact *Square Number*, and that 23426 is the *Root* thereof ; and so the whole Work being ended, it will stand as followeth.

$$\begin{array}{r}
 548777476 \quad (23426 \\
 4 \\
 \hline
 148 \\
 129 \\
 \hline
 1977 \\
 1856 \\
 \hline
 12174 \\
 9364 \\
 \hline
 281076 \\
 281076 \\
 \hline
 000000
 \end{array}$$

CHAP. XII.

A Brief and Compendious Way of Multiplication, wherein the Product is given at once, without several Workings, or writing down any other Figures but the Product it self.

I. *Example.* **L**ET it be required to multiply 7432, by 45.

$$\begin{array}{r} 7432 \\ \underline{45} \\ 0 \end{array}$$

$$\begin{array}{r} 7432 \\ \underline{45} \\ 40 \end{array}$$

$$\begin{array}{r} 7432 \\ \underline{45} \\ 440 \end{array}$$

$$\begin{array}{r} 7432 \\ \underline{45} \\ 4440 \end{array}$$

$$\begin{array}{r} 7452 \\ \underline{45} \\ 334440 \end{array}$$

Example
I.

$$\begin{array}{r} 524 \\ \underline{452} \\ 8 \end{array}$$

$$\begin{array}{r} 524 \\ \underline{432} \\ 68 \end{array}$$

$$\begin{array}{r} 524 \\ \underline{432} \\ 368 \end{array}$$

$$\begin{array}{r} 524 \\ \underline{432} \\ 6368 \end{array}$$

$$\begin{array}{r} 524 \\ \underline{432} \\ 226368 \end{array}$$

Example
II.

Set down the Numbers as in the *Margent*. Then,

1. Multiply as the line directs you; say 5 times 2 is 10, place 0 under Unites, and carry 1 in mind.

2. Say 5 times 3 is 15, and 4 times 2 is 8, which added together, with 1 in mind, makes 24, set down 4 in the next place on the left hand, and carry 2 in mind.

3. Say 5 times 4 is 20, and 4 times 3 is 12, which added together, with 2 in mind, makes 34, place the odd 4 in the next place, and carry 3 in mind.

4. Say 5 times 7 is 35, and 4 times 4 is 16, which added together, with 3 in mind, makes 54, set down 4 in the next place, and carry 5 in mind.

Lastly, Say 4 times 7 is 28, and 3 in mind is 33, which set down, and the work is at an end: And the Product of 7452 multiplied by 45, is 334440: As in the *Margent*.

II. *Example*, Multiply, 524 by 432:

1. Set the Numbers down, as in the *Margent*, and say (as the line directs) 2 times 4 is 8; set 8 in the place of Unites under 2.

2. Say 2 times 2 is 4, and 3 times 4 is 12, which added together make 16, place 6 under 3, and bear 1 in mind.

3. Say 2 times 5 is 10, and 3 times 2 is 6, and 4 times 4 is 16, which added together with 1 in mind, makes 33, place 3 under 4, and bear 3 in mind.

4. Say 3 times 5 is 15, and 4 times 2 is 8, which added together, with 3 in mind, makes 26, place 6 before 3, and bear 2 in mind.

Lastly, Say 4 times 5 is 20, and 2 in mind makes 22, which set down, and the work is at an end: And the Product of 524 multiplied by 432, will be 226368, as in the *Margent*.

C H A P. XIII.

Of Ceres and Virginum.

IN some Ancient, and in some late Writers of *Arithmetick* also, I find a Rule called *Ceres and Virginum*, which teacheth only how to resolve *Merry or Sporting Questions*, to puzzle young *Practitioners in Numbers*: And in regard that this *Book* is fraught with matters *Recreative*, I shall here insert it, with some Reflections upon it: And this Rule will be made appear best, by the Solution of certain *Questions* as properly belong to it; as such as here follow.

Question I.

A Lady's Caterer bought Eight Birds of two sorts, namely Geese and Hens, for 20 Shillings: The Geese cost 4 Shillings apiece, and the Hens 2 Shillings apiece: How many did he buy of each sort?

Multiply the whole number of *Birds*, viz. 8, into the *Least Price*, 2 s. the *Product* will be 16, which take from the whole number of *Birds*, viz. 20, there will remain 4 for a *Dividend*, which must be divided by the difference of the *Prices* of the two sorts of *Birds*, namely, by 2, and the *Quotient* will be 2 for the number of *Geese*; then must the *Hens* be 6. And so

2 Geese at 4 s. is — 8 s.
6 Hens at 2 s. is — 12 s.

In all 8.

In all 20.

Question II.

There were One and Twenty persons in Company, some Men, some Women, and some Children; and amongst them they spent 26 Shillings, and so, that every Man spent 2 Shillings, every Woman 1 Shilling, and every Child 6 Pence: How many must there be of each sort?

To resolve this or the like, this is the R U L E:

Multiply the Number of Persons by the least Expence, and take the *Product* of it from the whole Expence, the rest shall be the *Dividend*; which divided by the difference between the *Greatest and Least particular Expence*, the *Quotient* is a Number, which the number of Men (or they which spend most) comes near to, but cannot exceed. — Or if the said *Dividend* be divided by the *Sum* of the *Greatest and Least Expence*, the *Quotient* is a Number, than which the number of men, (or those which spend most) cannot be much less.

SO in this *Question*, 21 Persons multiplied by 6 Pence (the least Expence), the *Product* is $10\frac{1}{2}$, which taken from 26 (the whole Expence) the *Remainder* is $15\frac{1}{2}$ for the *Dividend*; and then taking $\frac{1}{2}$ from 2, there rests $1\frac{1}{2}$ for the *Divisor*, and the *Quotient* is $\frac{11}{3}$, which is something more than 10; the number of men therefore must be but 9.

Then turn the *Dividend* and the *Divisor* both into whole Numbers, by multiplying them into the common *Denominator* 2, so they being reduced, will be 31 and 3, as before is seen in the *Quotient*.

R E C R E A T I O N S

Multiply the *Divisor* 3 by 9 (which is the number of *Men*) the *Product* is 27, which taken from 31 (which is the reduced *Dividend*) the remainder is 4 for the Number of *Women*; and then the *Children* must be 8; as in the first Example.

		s.	
First	{ 9 Men, at 2 s. each	18	
	{ 4 Women, at 1 s. each, is	4	
	{ 8 Children, at 6 d. each	4	
	In all 21 Persons.		In all 26 s. expended.

But the number of *Men* may be also but 8, which multiplied by the reduced *Divisor* 3, it produceth 24, which taken from 31, the remainder is 7 for the *Women*; and then the *Children* must be 6: As in this second Example.

		s.	
Second	{ 8 Men, at 2 s. each	16	
	{ 7 Women, at 1 s. each	7	
	{ 6 Children, at 6 d. each	3	
	In all 21 Persons.		In all 26 s. expended.

Or the number of *Men* may be 7, which multiplied by 3, produceth 21, which taken from 31, there remains 10 for the *Women*, and then the *Children* must be 4, as in this third Example.

		s.	
Thirdly	{ 7 Men, at 2 s. each	14	
	{ 10 Women, at 1 s. each	10	
	{ 4 Children, at 6 d. each	2	
	In all 21 Persons.		In all 26 s. expended.

By what is here delivered in this second Question, it is plain that it is capable of several Solutions, and all of them true.

But further, The number of *Men* may be 10, and not more; for if you put them 11, that multiplied by 3 produceth 33, which is greater than 31 from whence it should be taken: But they may be 10, and then there is only One *Woman* and 10 *Children*; and this confirms the former part of the Rule.

Now for the later part of it: If the *Dividend* 31, be divided by the Sum of the two Extreams (reduced by doubling as the *Dividend* is) 4, the *Quotient* will be $7\frac{1}{4}$, and the *Men* may be 7 as hath been shewed; but they may be also but 6, and fewer they cannot be: As 6 *Men*, 13 *Women*, and 2 *Children*: For if you put the *Men* Five, that multiplied by 3, produceth 15, which taken from 31, there remains 16 for the *Women*, and so there should be no *Children*, which is contrary to the Supposition.

And further, Because the *Quotient* was $7\frac{1}{4}$, the number of *Men* might be so (if pure Arithmetical Division be only regarded.) And then the number of *Women* are $7\frac{1}{4}$, and the *Children* $5\frac{1}{4}$, as in this Example.

$7\frac{1}{4}$ Men,

	s.	d.
7. Men, at 2 s. each	15	6
$7\frac{3}{4}$ Women, at 1 s. each	7	9
$5\frac{1}{2}$ Children at 6 d. each	2	9

In all 21 Persons

In all 26 0 expended.

Question III.

There is 900 l. to be distributed by the Will of a Deceased Friend, to 30 Persons of three several Qualifications, as Ministers, Lame Soldiers, and Poor Tradesmen; so that each Minister may have 60 l. each Soldier 40 l. and each Tradesman 20 l. How many Persons of each Qualification must (or may) there be?

Multiply (according to the Rule) 30, the Number of Persons, by 20, the least Share, the Product is 600, which taken from 900, the whole Legacy, there remains 300 for the Dividend; and 20, the least share, taken from 60, the greatest share, leaves 40 for a Divisor; and so the Quotient will be $7\frac{1}{2}$, and more the Ministers cannot be: Also add 60 and 20 (the greatest and least Shares together) their Sum is 80, by which divide 300, and the Quotient will be $3\frac{3}{4}$, and much fewer the Ministers cannot be.

Not to stand upon the Fractions (in the dividing of Men)

$$\text{The } \left\{ \begin{array}{l} \text{Ministers} \\ \text{Soldiers} \\ \text{Tradesmen} \end{array} \right\} \text{ may be either } \left\{ \begin{array}{l} 7. \quad 6. \quad 5. \quad 4. \quad 3. \\ 1. \quad 3. \quad 5. \quad 7. \quad 9. \\ 22. \quad 21. \quad 20. \quad 19. \quad 18. \end{array} \right.$$

30

That the Ministers cannot (in whole Numbers) be more than 7 or less than 3, may thus be proved. — First, Let them be 8, then 8 times 40 is 320 which is more than 300, from which it should be taken. — Secondly, Let them be 2, then 2 times 40 is 80, out of 300 there remains 220, which divided by 20, gives in the Quotient 11 for the Soldiers; so the Ministers and Soldiers being 13, the Tradesmen must be 17.

But,

	l.
2 Ministers, at 60 l. each, is	120
11 Soldiers, at 40 l. each, is	440
17 Tradesmen, at 20 l. each, is	340

In all 900

Question

Question IV.

If there be Ten Persons of Four several Countries, English, Dutch, French and Spaniards, to pay a Debt of 1000 l. so that every English-man pays 50 l. every French-man 70 l. every Dutch-man 130 l. and every Spaniard 150 l. How many is there of each Country?

THE *Dividend* (according to the former Rule) is 500: Now to find the *Divisor*, take his Sum that pays least (namely 50 l.) out of each of the other three, 150, 130, and 70, and the remains will be 100, 80 and 20.

And the *First* and *Last*, viz. 120 for the *Divisor*; the *Quotient* will be $4\frac{2}{3}$, and the *Spaniards* cannot be more.

Secondly, Add the first and second together, viz. 180, the *Quotient* is $2\frac{14}{18}$; and the *Spaniards* cannot be less. That is,

The *Spaniards* cannot be much more than 4, or less than 2: And therefore, seeing any one Solution will serve,

Let the *Spaniards* be 3, and by that multiply 100, and take the *Product* out of 500, there remains 200 for a second *Dividend*, which divided by the second remain, 80, the *Quotient* is $2\frac{1}{2}$, therefore the *Dutch-men* are 2, which multiplied by 80, makes 160; take that out of 200, there remains 40 for a third *Dividend*, which divided by the third remain, 20, the *Quotient* is 2 for the *French-men* also, and consequently the *English-men* must be 3, because all of them are 10: But the *Spaniards* may be also 4 or 2.

Example.

	l.
4 Spaniards, at 150 l. each	600
1 Dutch-man, at 130 l.	130
1 French-man, at 70 l.	70
4 English-men, at 50 l. each	200
In all 10	In all 1000

Again,

2 Spaniards, at 150 l. each	300
3 Dutch, at 130 l. each	390
3 French-men, at 70 l. each	210
2 English, at 50 l. each	100
In all 10	In all 1000

The Reason why the *Spaniards* and *English*, as also the *Dutch* and *French*, are equal in number, is, because their Payments differ equally from 100, which is the *Mean Sum* with which 10 Men should pay 1000 Pound.

Question

NUMERICAL.

Question V.

If one should buy 12 Loaves of Bread for 12 Pence ; so that some might be Twopenny, some Penny, some Halfpenny, and some Farthing Loaves ; and it be required to know how many he must buy of each sort ?

NOW, Because of 12 Loaves for 12 Pence, the Mean Price is 1, but one of the Particulars being also 1, there should be no Penny Loaves, because there is no difference betwixt the Mean Price and One Penny.

But it may be found by this Rule to be either

4 Twopenny Loaves,	8 Pence
2 Penny Loaves,	2 Pence
2 Halfpenny Loaves,	1 Penny
4 Farthing Loaves,	1 Penny

In all 12 Loaves

In all 12 Pence

Or else it may be

3 Twopenny Loaves,	6 Pence
4 Penny Loaves,	4 9
3 Halfpenny Loaves,	1 2
2 Farthing Loaves,	0 2

In all 12 Loaves.

In all 12 0 Pence

And so much for this Rule.

C H A P. XIV.

Of Numerical Devices.

If any Person write down any three Digits (as 6, 8, 7) and under them make Nine other Digits set in Rank and File ; and under them you set Nine other Digits in the same order ; how to know, and set down the Agregate or total Sum of all the 18 Digits and the three first Figures, being added together ; before any of the 18 Digits be set down.

LET the three Figures first set down be 6, 8, 7, under them draw a Line, and under the Line make nine Pricks; and under them draw another Line, and under it make nine other Pricks, and a Line under them, as is done in the Margin: This done (always) subtract 3 from the Digit standing in the place of Unity, in this case 7, and the remainder is 4; then, upon a piece of Paper (by the bye) write down 6, 8, 4 instead of 6, 8, 7, and to the left hand of it set 3, instead of the 3 which you abated from the 7; so will your Number be 3684; and that will be the Aggregate or Sum of the 18 Digits, and the three uppermost Figures, all being added together: As in the following Example.

6	8	7
.	.	.
.	.	.
.	.	.
.	.	.
.	.	.
.	.	.
.	.	.

Having

R E C R E A T I O N S

Having set down the three Figures 687, and drawn under them a Line, and made 18 Points and Lines as in the Margin above, bid any Person about you write any nine Digits upon the nine upper Pricks, and you will write nine other upon the nine other Pricks below; all which being added together, shall make 3684.— Suppose (as in the Margin) on the uppermost nine Pricks be written 748—631—254; then do you, upon the nine Pricks under, write the Complements of those nine Figures to Nine; as for his three first 748 do you write 251, for 631 write 368, and for 254 write 745; all which added together, will make 3684, the Sum you first set down before any of the 18 figures were written.

422 *Example 2.* But if the Digit in the place of Unity be less than 3, as in these three figures 422, you must take 3 from 12, and there will remain 9, which set down; and (because you borrowed 10) take 1 from 2, and there remains 1, and 4 is the same 4, before which put 3 for the 3 which you borrowed, and then the Sum is 3419, which you tell beforehand will be the Aggregate or Sum of all the Addition, as in the Margin is plain.

The like may be done by 4, 5, 6 figures, by observing the same method, by abating of so many Unites from the place of Unity, and restoring again in the place of Thousands or Ten thousands, &c. As in these Examples,

6 7 8 5

2 3 6 8
7 5 2 1
8 3 7 2
6 1 5 4

7 6 3 1
2 4 7 8
1 6 2 7
3 8 4 5

4 6 7 8 1

2 5 7 9 8

2 0 3 6 8
4 2 6 0 0
5 3 4 1 1
2 7 0 6 9
8 3 5 0 2

7 9 6 3 1
5 7 3 9 9
4 1 5 8 8
7 2 9 3 0
1 6 4 9 7

5 2 5 7 9 3

If Three of a sort of the Five Odd Digit Numbers be set in Rank and File, as in the Margin, and it be required of any Five of these Odd Digits to make the just Number 20, How may that be done?

1 1 1	In the Performance of this there is a Falacy; for	6 6 6
3 3 3	no five odd Numbers taken howsoever, can make	L L L
5 5 5	up that Number; wherefore they do invert the	S S S
7 7 7	Numbers, by turning of the Paper upon which they	E E E
9 9 9	are written, upside down, and then the three Nines	I I I
	become three Sixes; and so 3 times 6 is 18, and two	
	of the Ones makes 20, as in the other Margin.	

Handwritten: *Geometrical Recreations*

Geometrical RECREATIONS.

C H A P. I.

Of Geometrical *Definitions*, and *Practical Problems*.

P R O B L. I.

From a Point, in a Right Line given, to erect another Right Line which shall be Perpendicular to the Right Line given.

Definition 1.] A Point is that which hath no Parts, and is the least imaginary thing that can be conceived in the mind: As this Point or Prick noted with Z.

Definition 2.] A Right Line is a Line drawn equally between two given Points, and is the shortest distance between them, as is this Line X Y, which is the shortest distance between the two Points X and Y.
X ——— Y.

Definition 3.] A Right Line is said to be Perpendicular to another Right Line, when it maketh the Angles on either side of the erected Line equal; that is, so that the erected Line inclines not either to the Right hand, or to the Left, but standeth upright upon the Line from which it is erected: As in the Right Line A B, is said to be Perpendicular to the Right Line C D, upon which it is erected, for that it inclineth neither to the Right or Left hand; and because the Angles on either side thereof are equal; namely, The Angle A B C on the one side, equal to the Angle A B D on the other side; either of which Angles are Right Angles, and the Right Line A B so standing is Perpendicular to the Right Line C D upon which it is erected.

A

Practice.]

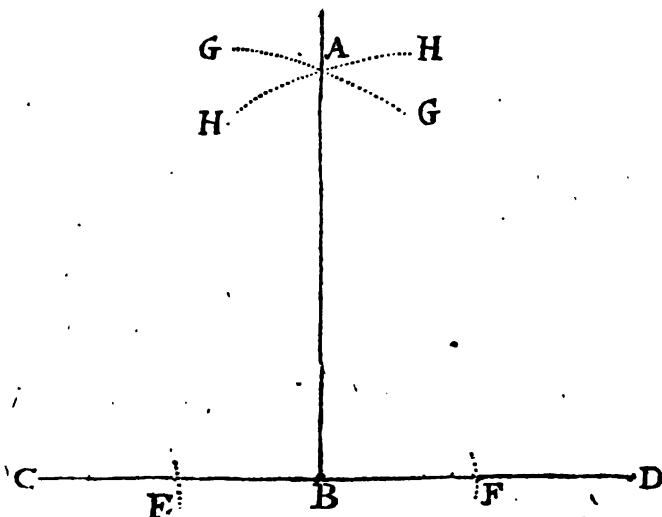

Practice.] **L**ET the Right Line given be CD, and let it be required to erect another Right Line which shall be Perpendicular thereunto, from the Point B.

Open your Compasses to any convenient small distance, and setting one Foot in the Point B, with the other make the two small marks E and F, on either side, equidistant from the given Point B. — This done, Open the Compasses again to any convenient distance (greater than

the former) and setting one Foot in the Point E, with the other describe the obscure Arch GG (over the given Point B as near as you can guess). — Again; (The Compasses being still open at the same distance) set one Foot in the Point F, and with the other describe another obscure Arch HH, crossing the former in the Point A: So is A a Point found, through which if you draw a Right Line from the given Point B, that Right Line AB, shall be Perpendicular to the given Right Line CD, and from the Point B, which was required to be done: And the Angle ABD, on the one side thereof, is equal to the Angle ABC, on the other side; and both of them are Right (or Square) Angles.

Note, An Angle is always signified by Three Letters, as a Point is by One; the middlemost of which Three representeth the Angular Point, as in this Case the Letter B. — B being the Angular Point, and the Lines AB and BC the sides containing the Angle B.

P R O B L. II.

How to erect a Perpendicular, when the given Point is in (or near) the end of the given Right Line.

Practice.] **T**HERE are several ways to effect this; of which I will here shew you only Two, as being the best.

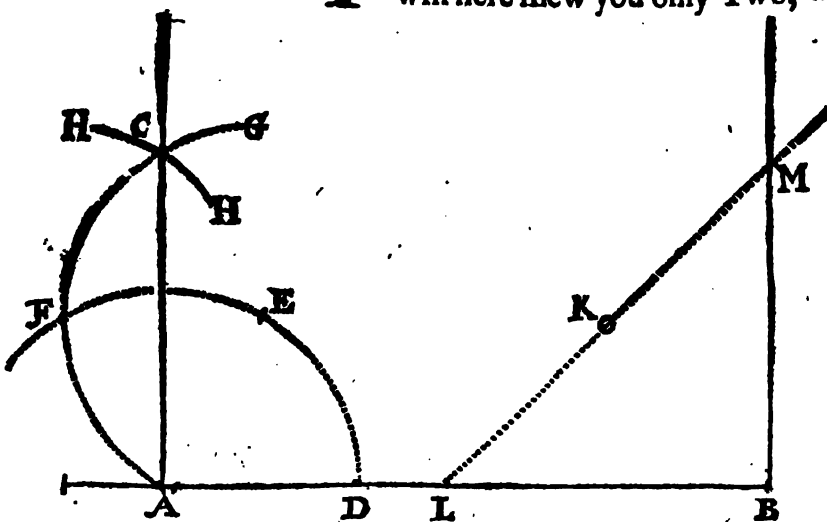

Let AB be a Line given, and from the Point A, towards the end thereof, let it be required to erect the Perpendicular AC.

— First, Open the Compasses to any small distance, and setting one Foot in the given Point A, with the other describe an Arch (or part) of a Circle, FE D, — And (keeping

G E O M E T R I C A L.

3

ing the Compasses still at the same distance) set one Foot in D, and make a mark in the Arch at E, and setting one Foot in E, with the other describe another Arch of a Circle AFG, crossing the first Arch in F. Again, Set one Foot in F, and with the other describe the small Arch H H, crossing the former in the Point C, through which Point C, draw a Line from the given Point A, and that Line shall be Perpendicular to the given Line A B, and drawn from the Point A, as was required. †

A Second Way.

Let B (the extreme end of the given Line) be the Point given. — Open the Compasses to any convenient distance, and setting one Foot in B, pitch down the other Foot at adventure in the Point K; so one Foot resting in K, turn the other about till it cross the given Line A B in L, and draw the right Line L K at length, and set the same distance K, L, (at which the Compasses already stand) from K to M; so a Line drawn from B through M, shall be Perpendicular to A B, and from the given Point B, as was required.

P R O B L. III.

From a Point above, to let a Perpendicular fall upon a Right Line under it.

IN this there are two Cases, — *First*, when the given Point above, is over (or near) the *middle* of the given Line. And — *Secondly*, When the given Point is just (or near) over the *End* of the given Line.

Præ- **I**N the first *Etice.*] Case, Let N O be a right Line given, and from the Point P (over it) let it be required to let fall the Perpendicular P Q. *First*, Open the Compasses to any convenient distance greater than the distance between P and Q; and setting one Foot in P, with the other draw an obscure Arch of a Circle, cutting the given Line in the Points R and S. — *Secondly*, Divide the Space between R and S into two equal parts in the Point Q; so a Right Line drawn from the given Point P, to the Point Q, shall be Perpendicular to the Line N O.

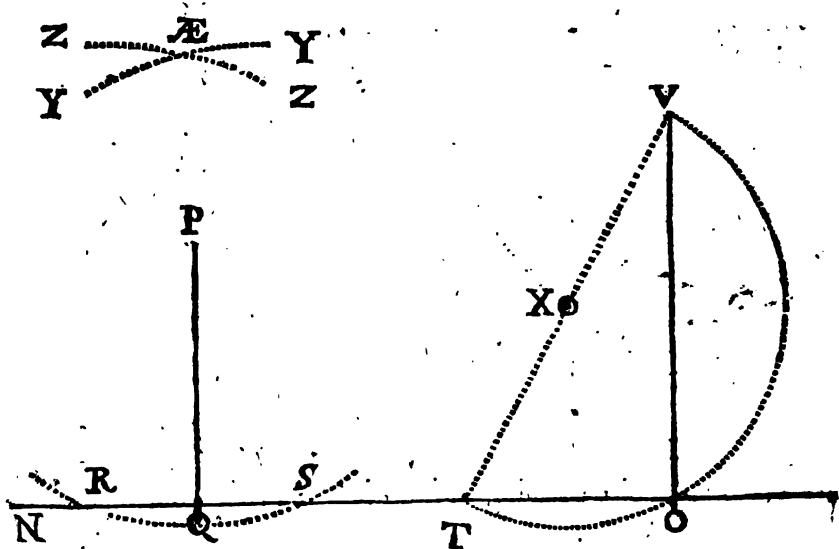

R E C R E A T I O N S

Note. To avoid the dividing of the space R S into two equal parts, to find the Point Q; if you have room (either above or beneath your Line) you may set one Foot in S, and opening the Compasses to any convenient distance, make the Arch Y Y, and removing the Compasses to R, make the Arch Z Z crossing the former in \mathcal{E} , so a Line drawn through \mathcal{E} and P, shall be Perpendicular to N O.

In the second Case, Let V be the Point given; — *First,* From any part of the given Line N O, as from T, draw a Right Line to the given Point V, which divide into two equal parts in X. — *Secondly,* Set one Foot of the Compasses in X, and with the distance X T describe the Arch (or Semicircle) V O T, cutting the given Line N O in O, so shall O be the Point, to which from the given Point V, if you draw a right Line, it shall be a Perpendicular to the Line N O, and from the Point V, as was required.

P R O B L. IV.

To divide a Right Line into Two equal Parts, and at Right (or Square) Angles.

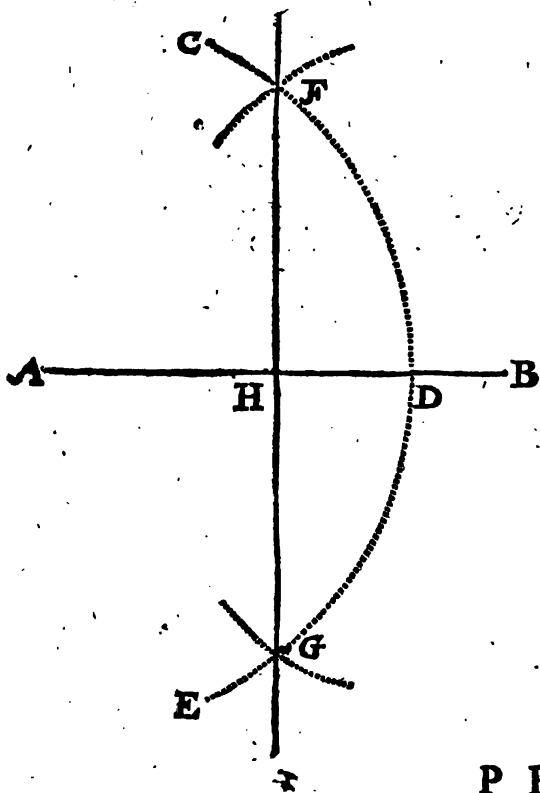

LET A B be a Line given, to be so divided. — Take in your Compasses the Length of the given Line A B; or (if that be too long) to any other distance greater than half the length thereof; and setting one Foot in the end A, with the other draw the Arch C D E. — *Secondly,* (the Compasses being open at the same distance) set one Foot in B, and with the other cross the former Arch (both above and below the Line) in the Points F and G: So a Right Line drawn (or a Ruler laid) from F to G, shall cut the given Line in H; so shall the given Line A B be divided into two Equal Parts in the Point H, and at right Angles, which was required.

P R O B L. V.

A Right Line being given, to draw another Right Line which shall be Parallel thereunto at any distance required, or through any Point assigned.

Definition.] **R**ight Lined Parallels are such Right Lines, which being drawn upon the same Plain, and infinitely extended on either side, would never concur or meet; but always, in all parts, retain

G E O M E T R I C A L

retain an equal distance; and such are these | B ————— C
two Right Lines, B C, and B D. | B ————— D

In the describing or drawing of *Parallel Lines*, there may fall out *Two Cases*, or *Varieties*. As,

1. It may be required to draw a Line *Parallel* to another Line, at a certain given distance. Or,
2. The *Parallel* may be required to be drawn through an assigned *Point*.

And of this kind there are two *Varieties*. For,

1. The given *Point* may be *over* or *under* the given Line. Or,
2. It may be *Oblique* to the Line given.

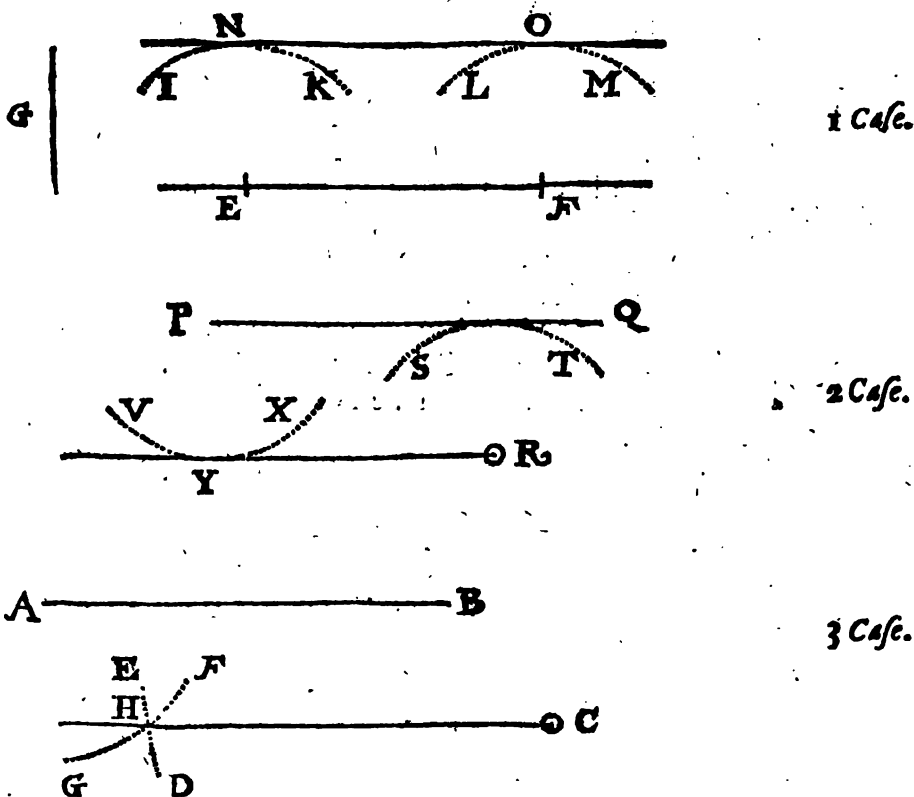

Practice of the **L** ET EF be a Right Line given, and let it be required to draw another Right Line Parallel thereunto at the distance of the Length of the Line G.

First, Take in your Compasses the Length of the given Line G, and set one Foot in the Point E, (or in any other part of the given Line towards the end thereof) describing the small obscure Arch IK. — Then move the Compasses to F, (near the other end of the Line) and describe another small and obscure Arch LM. — Lastly, Lay a Ruler to the very top of these two *Arches*, so that the Ruler do not cross, but justly touch either of them: Then if by the edge of the Ruler you draw a Right Line NO, it shall be Parallel to the given Line EF, and at the distance of the Length of G; which was to be done.

Prac

Practice of the **L** ET PQ be a Right Line given, unto which you are
Second Case. **L** to draw another Right Line Parallel, which Pa-
 rallel must pass through the given Point R.

First, Set one Foot of your Compasses in R, and with the other take the nearest distance to the given Line PQ, which is done by opening or shutting of the Compasses, till the moveable Point of them do only touch the given Line PQ, and there describe the Arch ST. — *Secondly,* The Compasses at the same distance, set one Foot in P, (or any Point towards the other end of the given Line) and with the other describe the Arch VX. — *Lastly,* Through the given Point R, and the very top of the Arch VX at Y, draw the Right Line RY, and it shall be Parallel to the given Line PQ, and shall also pass through the given Point R; which was required to be done.

Practice of the **L** ET AB be a Right Line given, to which another
Third Case. **L** Parallel Right Line is to be drawn, which shall pass through the Point C.

First, Take in your Compasses the distance from C to B, the end of the given Line. — *Secondly,* Set one Foot in A (the other end of the given Line) and with the other describe the obscure Arch FG. — *Thirdly,* Take in your Compasses the Length of the given Line AB, and setting one Foot in C, with the other describe the Arch DE, crossing the former in the Point H: So a Line drawn from the Point C, through the Point H, shall be Parallel to the given Line AB; which was required.

P R O B L. VI.

To make a Triangle of any three given Right Lines, provided that the two shorter Lines together, be longer than the longest given Line.

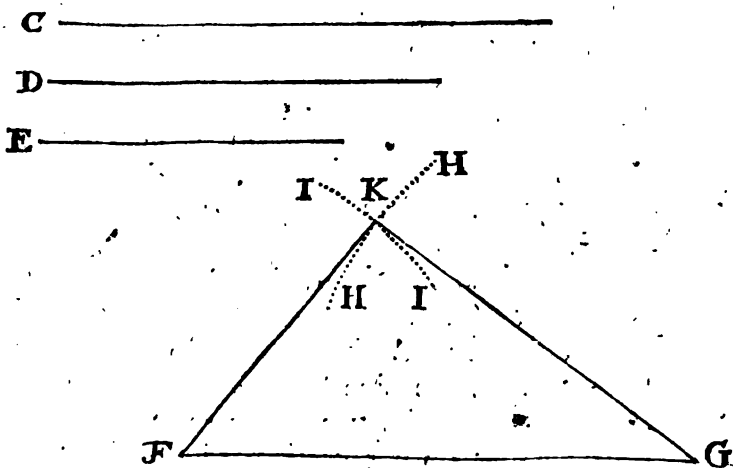

First, Take the longest Line C in your Compasses, and make the Line FG equal thereunto. *Secondly,* Take in your Compasses the Line D, and setting one Foot in G, describe the Arch H H. — *Thirdly,* Take the Line E, and setting one Foot in F, describe the Arch I I, crossing the former Arch in K. — *Lastly,* draw the Right Lines KF and KG, and they shall constitute a Triangle, whose three sides shall be equal to the three given Lines, C, D, E; which was required.

P R O B L.

P R O B L. VII.

To divide a Right Line given, into any number of Equal Parts.

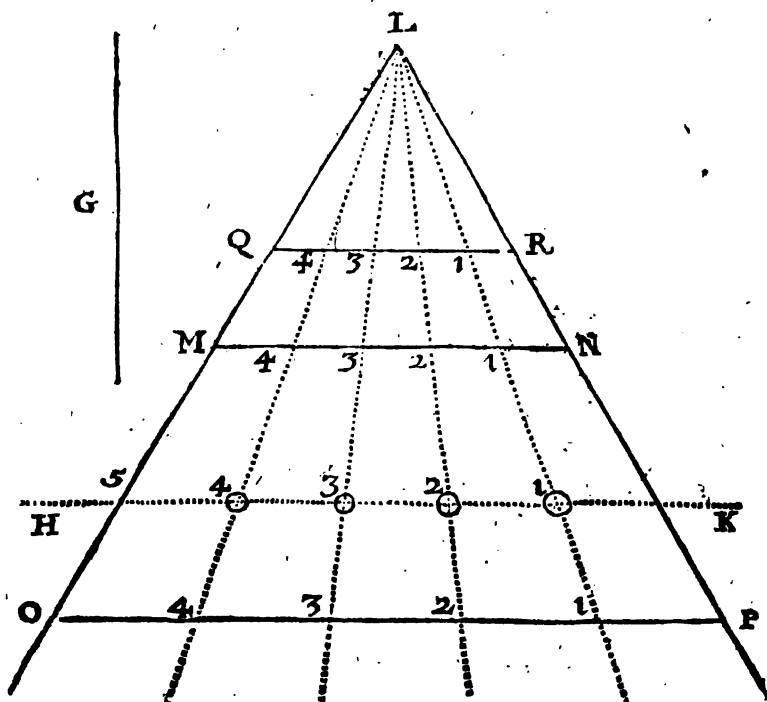

Practice.] **L** ET the Right Line G be the Line given, to be divided into 5 equal parts. First, Upon any Line drawn at pleasure, as the obscure Line HK, with your Compasses opened to any small distance, run along the same Five times at the figures 0, 1, 2, 3, 4, 5. (because the Line given is to be divided into 5 parts). — Then take in your Compasses the distance from 0 to 5, and with that distance make the *Equilateral Triangle* 5LO. — Again, Take in your Compasses the given Line G, and set that distance from L to M and N, drawing the Line MN (which will be equal to the given Line G.) — Lastly, Lay a Ruler from L, to the Points 1, 2, 3, and 4, in the Line HK, and the Ruler will cut the Line MN in the Points 1, 2, 3, 4; dividing the same Line, equal to G, into 5 equal parts; as was required.

¶ *Note,* This *Equilateral Triangle* thus made, is capable of dividing any other Line into 5 equal parts, be it either greater or lesser than this given Line G, if the length thereof be set from L on both sides of the Triangle, and drawing a Line from either side: As the Line QR shorter than MN; or the Line OP longer than MN: All which Lines are divided into Five Equal Parts.

P R O B L. VIII.

To any three Points given, which lye not in a Right Line, to find the Center of a Circle, whose Circumference being described, shall pass through those three given Points.

Let

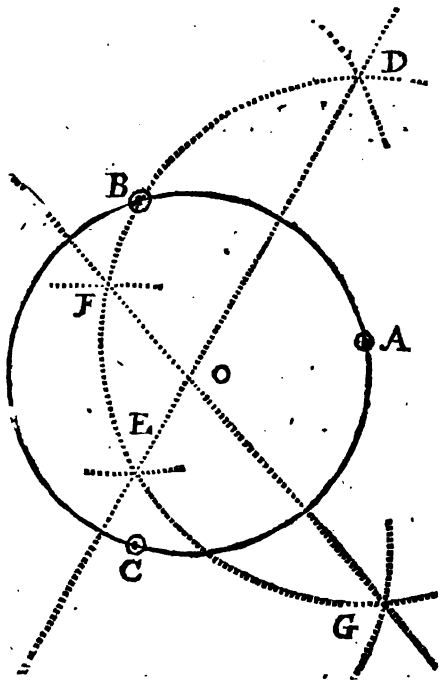

LET the three given Points be A B C. *First*, Set one Foot of your Compasses in one of the given Points A, and extend the other Foot to B, another of the given Points, and draw the Arch of a Circle G E D. — *Secondly*, (the Compasses being kept at the same distance as before) Set one Foot in B, and with the other Foot cross the former Arch G E D, with two small Marks or Arches in the Points D and E, and draw the Right Line D E. — *Thirdly*, Set one Foot of the Compasses in the third given Point C, (they still keeping the same opening) and with the other Foot cross the first drawn Arch G E D, in the Points F and G, and draw the Right Line F G, crossing the former Right Line D E in the Point O, so shall O be the Centre of a Circle; in which if you set one Foot of the Compasses, and open the other to any of the three given Points, the Circle so described shall pass directly through all the 3 Points A B and C, as was required.

P R O B L. IX.

To divide the Circumference of any Circle into any number of equal Parts, not exceeding Ten.

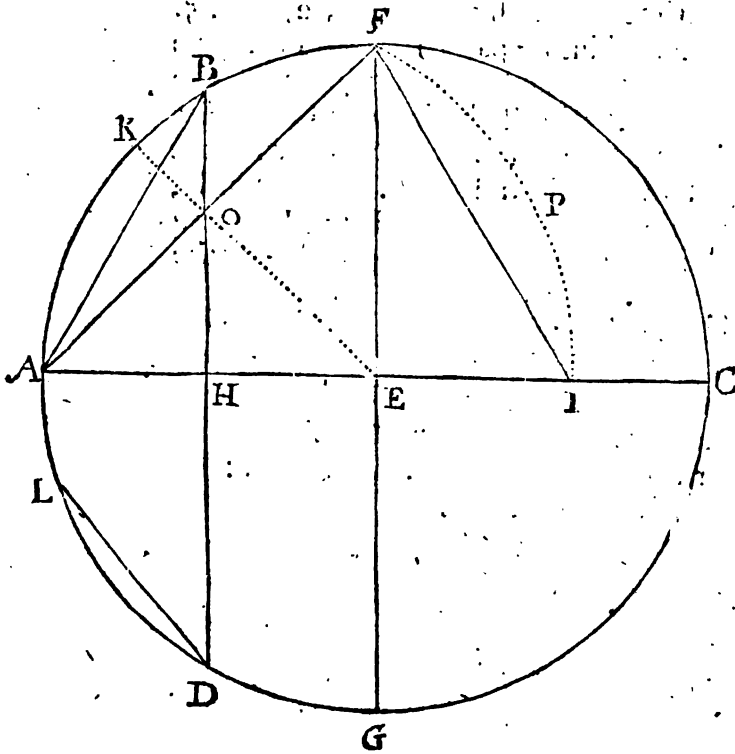

THE Circle being described upon the Centre E, — *First*, Draw the Diameter A E C, which divides the Circumference into 2 equal parts. — *Secondly*, Take the distance A E in your Compasses, and set it from A to B, and to D, and draw the Line B D, which shall divide the Circumference into 3 equal parts. — *Thirdly*, Divide the Diameter A C in two equal parts at right Angles, by the Diameter F G, and draw the Line A F, which shall divide the Circle into 4 equal parts. — *Fourthly*, Set one Foot of the Compasses in H, and extend the other to F, and there describe the Arch F P I, and draw the Line F I, which shall divide

there describe the Arch F P I, and draw the Line F I, which shall divide

G E O M E T R I C A L

vide the Circle into 5 equal parts. — *Fifthly*, The lines E A, E C, E F, or E G, will either of them divide the Circle into 6 equal parts. — *Sixthly*, The lines H B or H D will divide it into 7 equal parts. — *Seventhly*, Through the point O, (where the lines H B and A F do intersect) draw the line E K, and a line drawn from A to K shall divide the Circle into 8 equal parts. — *Eighthly*, Divide the Arch B A D into three equal parts, and set one of them from D to L, so shall D L divide the Circumference into 9 equal parts. — *Lastly*, The Line E I will divide the Circle into 10 equal parts; and so is the Problem performed as was required.

P R O B L. X.

To divide a Right Lined Angle into two equal Parts.

LET the Angle given be C A B; upon the Angular Point at A, with any distance of the Compasses, describe an Arch a b, then set one foot in a, and with the other describe the Arch c c, and set one foot in b, and with the other describe the Arch d d, crossing the former in the point D, through which draw the Line D A, so shall the Angle C A B be divided into two equal parts by the Line D A.

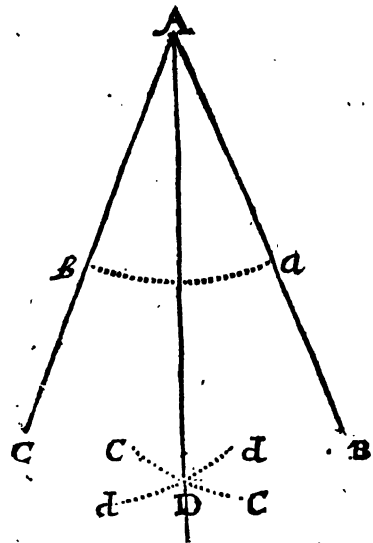

P R O B L. XI.

How to describe a Circle within a Triangle, so that the Circumference of the Circle shall touch all the three sides of the Triangle.

BY the last Problem divide any two of the Angles of the given Triangle into two equal parts, as the Angles E F G, by the line F f, and the Angle E G F by the line G e, cutting each other in H; so is H the Center, upon which if you describe the Circle, it shall touch the three sides of the Triangle in the Points I K and L.

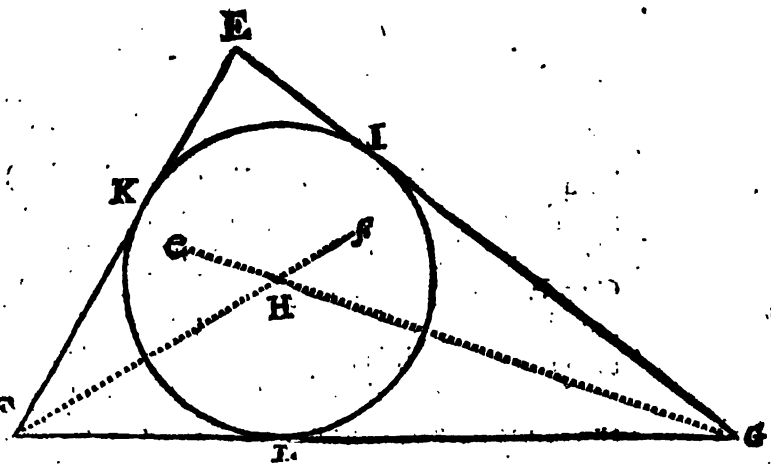

P R O B L. XII.

To describe a Circle about a Triangle, the Circumference whereof shall touch all the Angles of the Triangle.

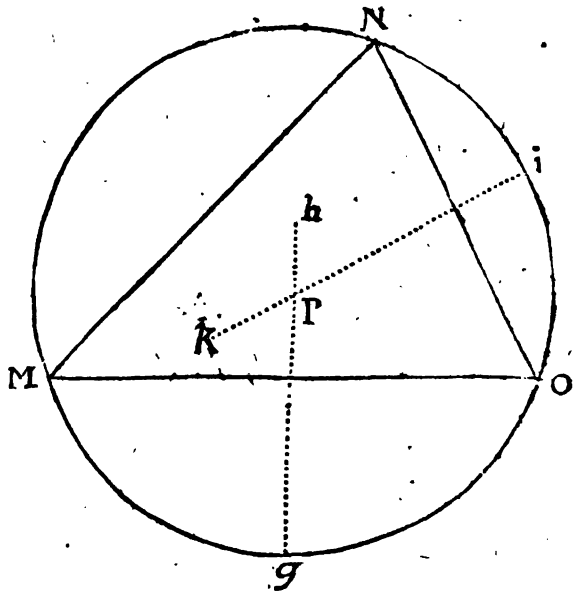

LET the Triangle given be M N O, by the fourth Problem divide any of the two sides of the Triangles into two equal parts, at Right Angles, as the side M O, by the line g h, and the side N O, by the line i k, crossing each other in P; so is P a Center, upon which if you describe a Circle, it shall touch all the Angles of the Triangle.

P R O B L. XIII.

Between two Right Lines given, to find a Mean Proportional Line.

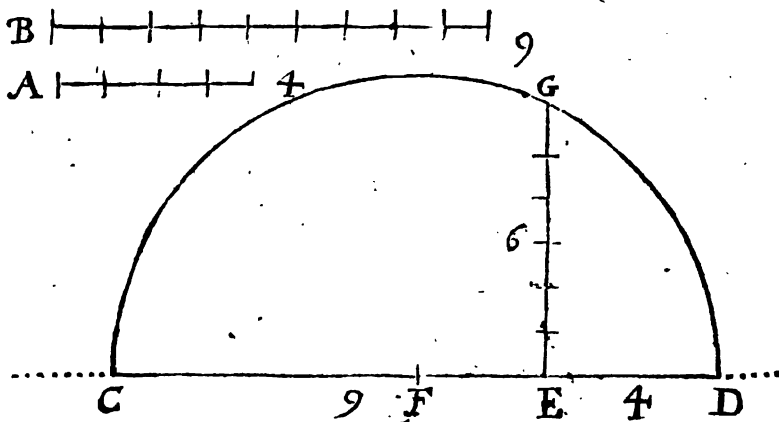

Defini-
tion. A Mean Proportional Line, is such a Line, whose length being multiplied in it self, the Product shall be equal to both the Product of the other two Lines, between which it is a Mean Proportional.

Let A and B be two lines, of which let A be 4 of any Measure, (as Feet, Yards, &c.) and let B be 9 of the same measure; and between these two I would find a Mean Proportional.

Draw a right line C D, and upon it set the line B, which is 9, from C to E; also set the line A, which is 4, from E to D; so is the line C D, equal to the two lines A and B; upon the point of the joining of these two lines, which is at E, (by the first Problem) erect a Perpendicular, as E G; then divide the line C D into two equal parts in F, and upon the point F, as a Center, describe a Semicircle C G D, cutting the Perpendicular before erected, in the point G; then is the line E G a Mean Proportional Line between the two lines A and B, and being measured, will

will be found to be 6 ; which being multiplied in it self produceth 36 ; and so will 9 multiplied by 4 produce the same.

P R O B L. XIV.

How to make a Serpentine or Spiral Line, whose thrids shall be distant one from the other, the length of a Line given.

LET it be required to describe a Spiral Line, at the distance of the given Line A B. — Continue the given line A B at pleasure on both sides, from A towards D, and from B towards E ; and upon this continued Line (with the distance A B) set off the distances 1, 2, 3, &c. on either side from A and B. Then (by Probl. 1.) divide the given line A B into two equal parts in the point C, and upon C, as a Centre, at the distance C A or C B, describe the Semicircle A a B : Then opening the Compasses from C to 1, upon C describe the Semicircle 1 b 1 ; also extend the Compasses from C

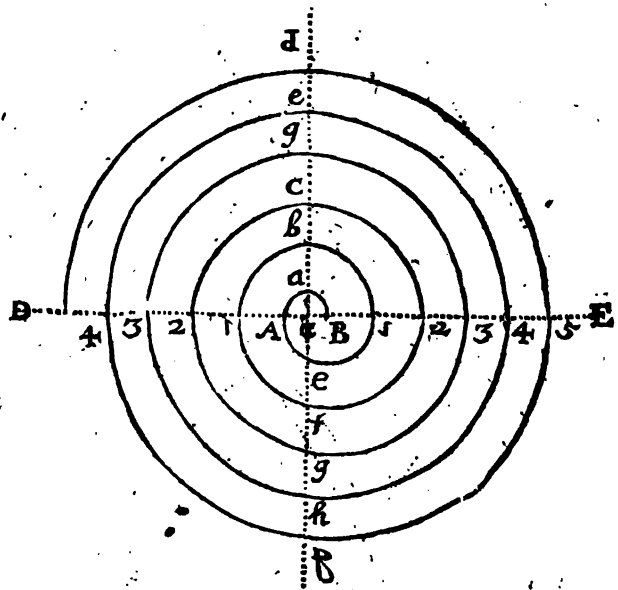

to 2, and upon C describe the Semicircle 2 c 2. Again, Open the Compasses from C to 3, and describe the Semicircle 3 d 3 : And thus may you do for as many Revolutions as you please, as here is done only for three.

Again, Open the Compasses to the distance of the given line A B, set one foot in B, and with the other describe the Semicircle A e 1. Then extend the Compasses from B to 1, and describe the Semicircle 1 f 2. Lastly, Extend the Compasses from B to 2, and describe the Semicircle 2 g 3. So is your Spiral Line finished, consisting of Three Revolutions only, but may be continued to as many as you please.

P R O B L. XV.

How to describe an Oval, the length thereof being given.

B 2

LET

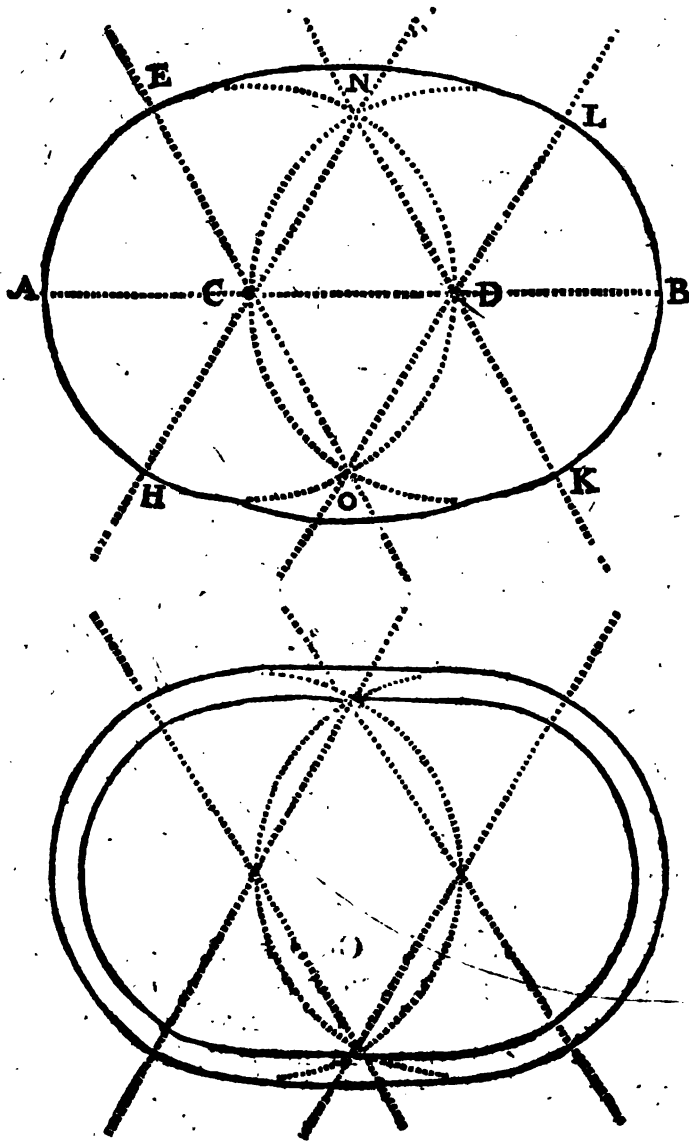

LET AB be a line given, and of that length let it be required to describe an Oval. — Divide the line AB into three equal parts in the Points C and D . Then upon C as a Centre, at the distance CA , describe the obscure Circle $EAHD$; and upon D , at the distance DB , describe another occult Circle $LBKC$, crossing the former in the points N and O . This done, through O and C draw an obscure line cutting the Circle in E : Also through O and D , draw another obscure line, crossing the other Circle in L . In like manner, through the points N and C , draw an obscure line cutting the Circle in H , and through N and D another cutting the Circle in K . Lastly, Upon O , at the distance OE or OL , describe the Arch EL , and (with the same distance) upon N , describe the Arch HK . The two ends of the Oval HAE , and LBK are parts of the two Circles first of all described; and so is your Oval completed.

If you would draw an Oval Parallel to an Oval, you must describe it upon the same Centres, and to touch the lines OE , OL , and NH , NK , extended as is done in the Figure.

PROBL. XVI.

At the length of a line given, to describe an Oval, which shall be in proportion to the length thereof, narrower than the former.

LET

LET the given line
be P Q — Di-
vide the line P Q
(by the 13th. Probl.)
into four equal parts
in the points R S and
T, and upon those
three points, as three
Centers, at the di-
stance R P, or T Q,
describe three Cir-
cles, the middlemost
of which, described
upon the Center S,
cutting the other
two in the points U
X Y Z. This done,
through the points
R Z draw an obscure
line at length, and
cutting one of the
Circles in A; also
draw a line through

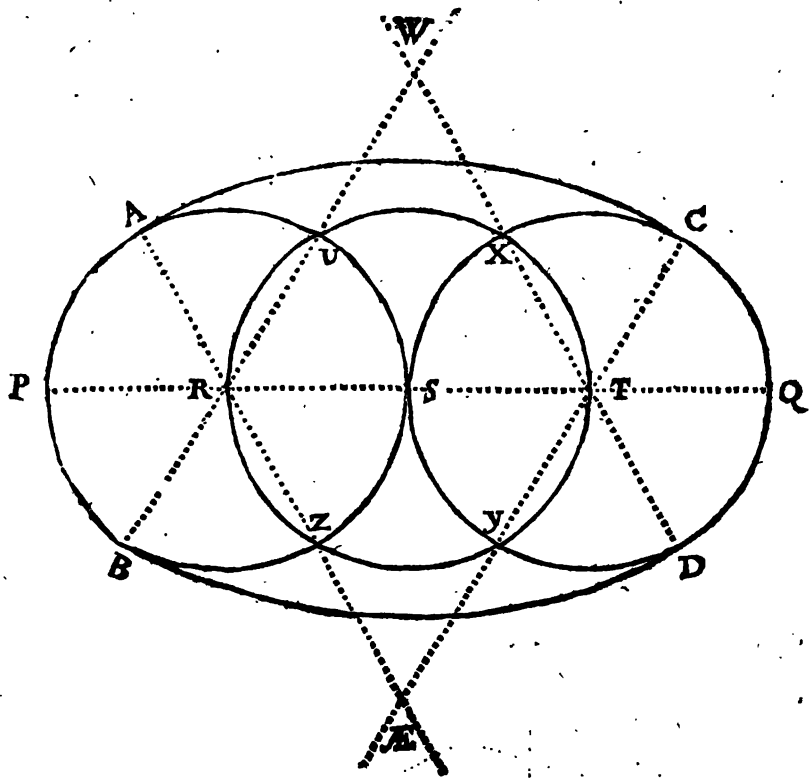

T and Y, crossing the other Circle in C, and the line A Z extended to A.
— Again, through T and X draw an obscure line at liberty, cutting
one of the Circles in D, and another obscure line through R and V, cut-
ting the other Circle in B, and being extended through the former occult
line in W. Lastly, Upon the Point A, at the distance A A, describe the
Arch A C, and (with the same distance) one foot placed in W, with
the other describe the Arch B D, completing the Oval; the ends A P
B, and C Q D, being parts of the two outermost Circles first described.

*If you would have an Oval Parallel to this, it must be described upon the same
Centres R T W and A.*

P R O B L. XVII.

How to make an Egg Form.

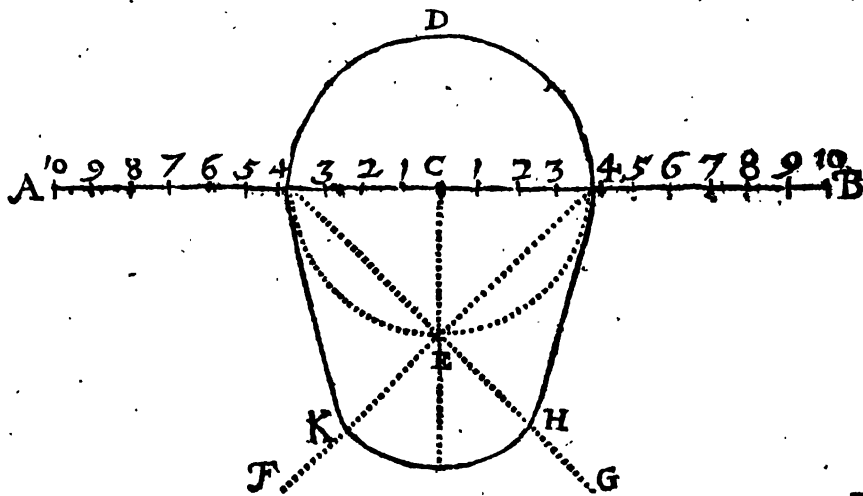

Draw

Draw a right line $A B$, which divide into two equal parts in C . Then divide each of those parts $C B$ and $C A$ into 10 equal parts, and number them from C both ways, by 1, 2, 3, &c. to 10. — Then take in your Compasses 4 of those parts, and with that distance, upon C , describe the Circle $D E$, and draw the two lines $E F$, and $E G$, extending them of sufficient length. — Then setting one foot of the Compasses in B , extend the other to the 4 next to A (or take 14 parts in your Compasses) and setting one foot in A describe an Arch till it cut the line $E G$ in H , and with the same distance, setting one foot in B , describe an Arch, cutting the line $E F$ in K . — Lastly, Set one foot in E , and with the other, opened to the distance $E K$ or $E H$, describe the Arch $K L H$; and so is your Egg figure compleated.

P R O B L. XVIII.

How to describe an Oval (properly an Ellipsis) whose length and breadth is given.

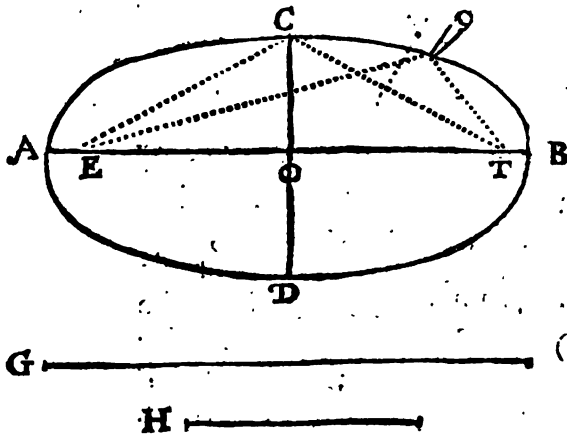

LET G and H be two lines given, and an Oval (or Ellipsis) is to be described, whose length is to be equal to the line G , and its breadth to the line H . — Draw a line $A B$ equal to the line G , and (by Probl. 1.) divide it into two equal parts at Right Angles in the point O , and make the line $C D$ equal to the given line H . This done, take in your Compasses the length $O A$ or $O B$, (half the length of the longest Diameter) and setting one foot in C , with the other cross the Diameter

$A B$, in the points E and F ; which two points are the two Centers of the Oval, (properly the two Focus of the Ellipsis): Upon which two points, let two Pins be fastned, and about them put a String, whose ends fasten together in the point C ; this string being moved about the two Pins with a Point or Tracer, will describe the Oval (or Ellipsis) $A C B D$, whose length and breadth shall be equal to the two lines G and H .

P R O B L. XIX.

To find the Center of a Circular Arch, and the whole Diameter of the Circle, of which the given Arch is a part or Segment.

L E T

LET ABC be the inside of a Circular Arch, of which the whole Diameter and the Center is required to be found.—Make choice of a Point towards the Top or Crown of the Arch, as B; in which set one foot of the Compasses, opening them to any competent distance, as from B to D or E, and with that distance describe an obscure Circle FDEG, crossing the Arch in D and E. Then (the Compasses being still open to the same distance) set one foot in D, and with the other make the marks F and L in the obscure Circle: Also set one foot in E, and with the other make the marks K and M in the same obscure Circle. This done, draw an occult line at pleasure, through the points H and L, and another through M and K, crossing the former in the point O: So shall O be the Center of the Arch, and OA, OB, or OC, the Semidiameter of the Circle of which the Arch is a part. The whole Diameter may be found by continuing the sides of the Arch from the Springs A and B, downwards towards P and Q: Then a line drawn through the Center O, parallel to AB, till it meet with the Arch continued on both sides at P and Q, shall be the Diameter of the Arch.

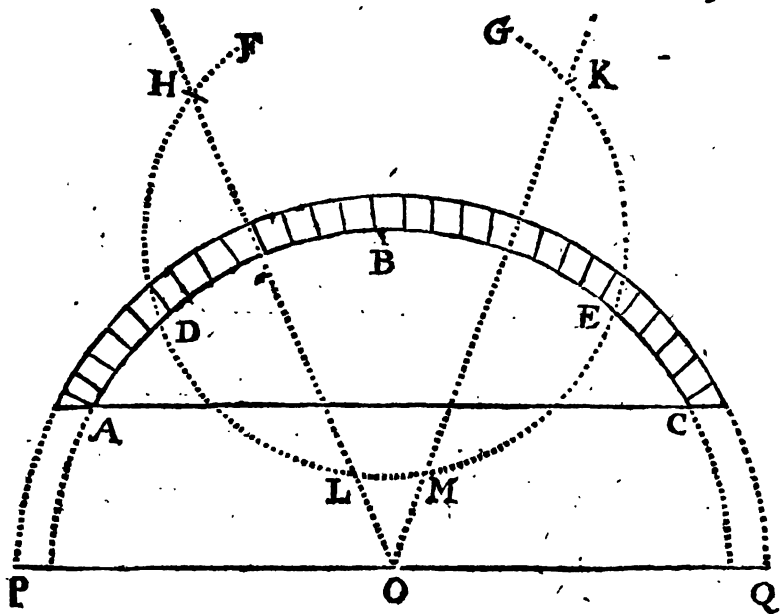

P R O B L. XX.

The Arch or Segment of a Circle being given, to find a Right Line (the nearest) equal thereunto.

THE Arch RST is a Segment of a Circle, unto which a Right line is to be made equal.—From the two extrem points of the Arch, draw a right line RT; then divide the Arch line into two equal parts in S, and draw the right line ST. This done, draw a right line at pleasure, as Wm; upon which line set the length of the line RT, from W to X: Also take the line TS in your Compasses, which at twice will reach from W to Y; divide the line of difference XY into 3 equal parts, and one of those parts set from Y to Z; so shall the right line WZ, be the nearest right line that can Geometrically be found, equal to the Arch Line or Segment RST.

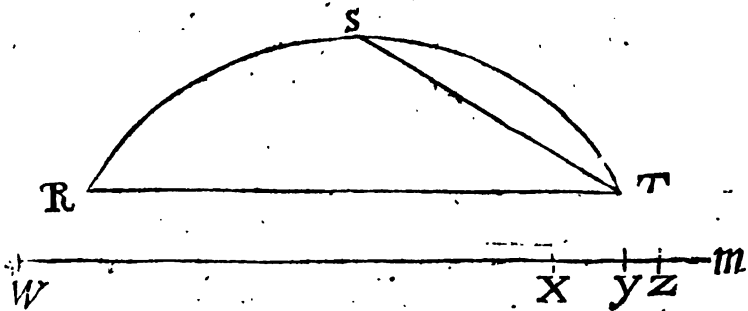

C H A P. II.

Geometrical Conclusions.

S H E W I N G

How (without Compasses) having only a common Meat-Fork, (or such like Instrument, which will neither open wider, nor shut closer), and a Plain Ruler, to perform many pleasant and delightful Geometrical Conclusions.

THE *Compasses* is an Instrument known to all men; and the Invention of them is attributed to *Talus* the Nephew of *Dedalus*; as appears by *Ovid Met. Lib. 8.* Where he says,

*— Et ex uno duo ferrea brachia nodo
Junxit, ut equali spacio distantibus illis
Altera pars stare, pars altera duceret orbem.*

Which *Sandys* thus Translates;
And two shankt *Compasses*, with Rivet bound,
Th'one to stand still, th'other to turn round
In equal distance.

But one *John Baptist* an *Italian*, as also one *Feronymus Cardanus*, a famous Mathematician, have performed and demonstrated all (as is related) *Euclid's* Elements, without *Compasses*; it is true, many Conclusions may be done without them, some whereof shall here follow:

C O N C L U S. I.

How to divide a Right Line into two equal Parts.

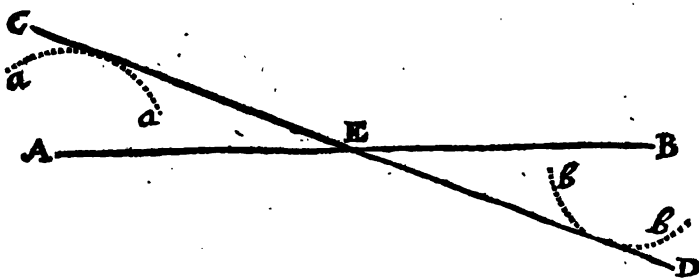

LET *AB* be a right-line given to be divided into two equal parts; set one point of the Fork in *A*, and with the other draw the small Arch *a a*; then set one end of the Fork in *B*, and with the other describe the Arch *b b*; then lay a Ruler to these two Arches *a a* and *b b*, so that the Ruler may only touch the tops of the Arches; then by the side of the Ruler draw the line *CD*, which will divide the given line *AB* into two equal parts in the point *E*; which was to be done.

C O N -

C O N C L U S. II.

How to erect a Perpendicular from a Point given in any Right line.

This may be done several ways; as followeth:

The First Way.

Let FG be a right line, and H a point given therein, from whence it is required to erect a Perpendicular: Set one point of the fork in the given point H , and run it over upon the given line two, three, or four times, on either side of the given point H , at the Points $3\ 2\ 1$, and $1\ 2\ 3$; then upon the points 3 and 3 , describe the two Arches $3\ c$, and $3\ d$, setting the distance of the fork upon both the Arches from 2 to c , and from 2 to d : Then through the points 3 and c , and 3 and d , draw the two right lines $3\ c$, and $3\ d$, cutting one another in the point K ; so a right line being drawn from H to K , shall be Perpendicular to FG ; which was required to be done.

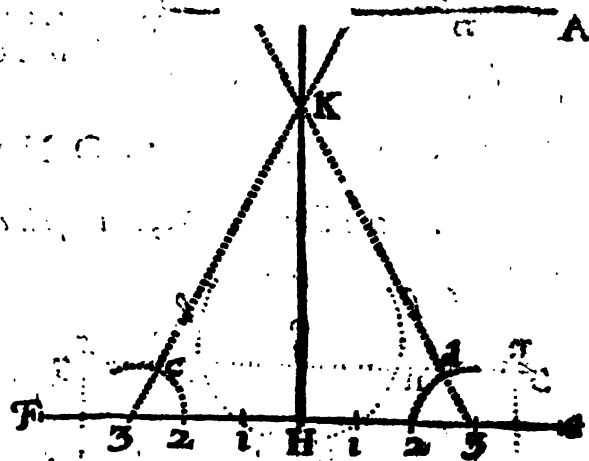

Another Way.

Let LM be a right line given, and N a point therein; from whence a Perpendicular is to be erected. Set one foot of the fork in the given point N , and with the other describe the Semicircle $e\ f\ g\ h$; then setting one foot in e , the other will reach to f ; and setting one foot in h , the other will reach to g ; then setting one foot in f , with the other describe the small arch $i\ i$, and and setting one foot in g , with the other describe the small arch $k\ k$, crossing the former arch in O , from the given point N draw the line NO , which shall be perpendicular to the line LM ; which was to be done.

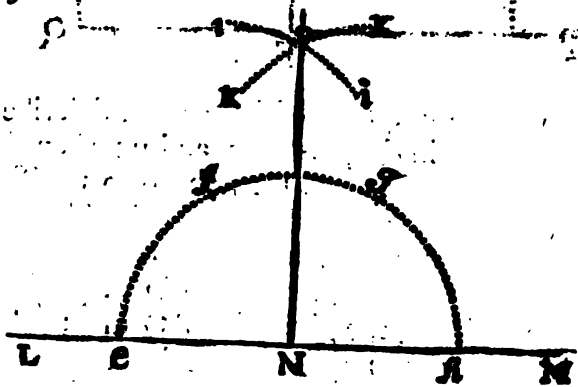

C O N C L U S. III.

Upon the End of a Right Line given, to Erect a Perpendicular.

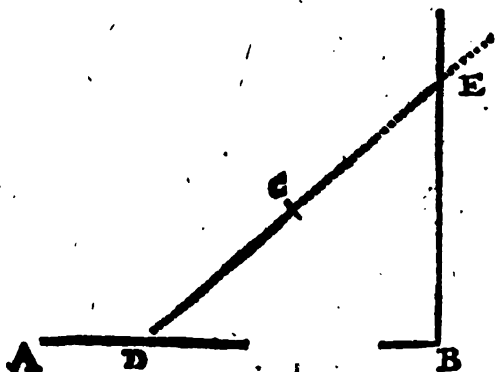

LET the given line be A B, and let it be required to erect a Perpendicular thereunto upon the end B. — Set one point of your fork in the end B, and keeping it there, pitch the other down upon the Paper at all adventures in C, and upon C turn the fork about till the other point of it touch the given line A B in D ; lay a Ruler from D to C, and draw an obscure line by the side thereof, and upon it set the distance of your fork from C to B ; then a line drawn from B through E, shall be Perpendicular to the given line A B.

CONCLUS. IV.

From a Point above, to let fall a Perpendicular upon a ground line below.

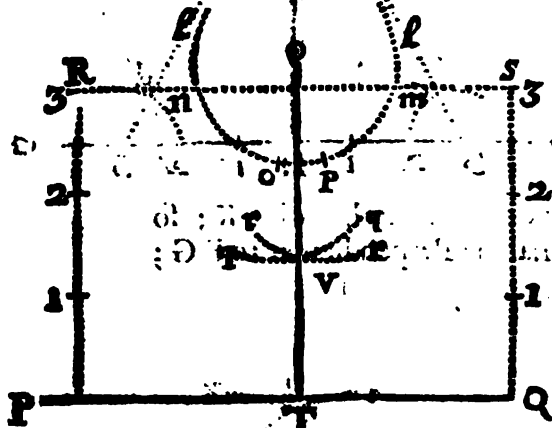

LET \odot be a point aloft, from which point it is required to draw a line which shall be Perpendicular to the right line P Q.

Upon the ends or towards the ends of the given line, erect two Perpendiculars as P R and Q S, upon which run over your fork as many times as you can, as at 1 1, 2 2, 3 3, &c. so far, till you come to have your given point to be nearer to the Parallel Line 3 3, than is the distance of your fork : Then set one foot of the fork in the given point

\odot , and with the other describe the Arch l l, cutting the Parallel 3 3, in the points m and n; then set one foot of the fork in m, and the other will reach to o; also set one foot in n, and the other will reach to p. Again, set one foot in o, and with the other describe the arch q q, and setting one foot in p, with the other describe the Arch r r, crossing each other in V. Lastly, draw the line \odot V, extending it till it cut the given line P Q in T; so shall \odot T be Perpendicular to P Q; which was required to be done.

CONCLUS. V.

To divide a Right Line into any number of equal parts.

LET

THE

LET WX be a right line given to be divided into 4 equal parts.

First, Upon the two points W and X, describe the two Arches a a above, the other b b below; then lay a Ruler to W, so as to touch the top of the Arch b b, and draw the line WZ, laying a Ruler to the top of the Arch a a, and the Point X, and draw

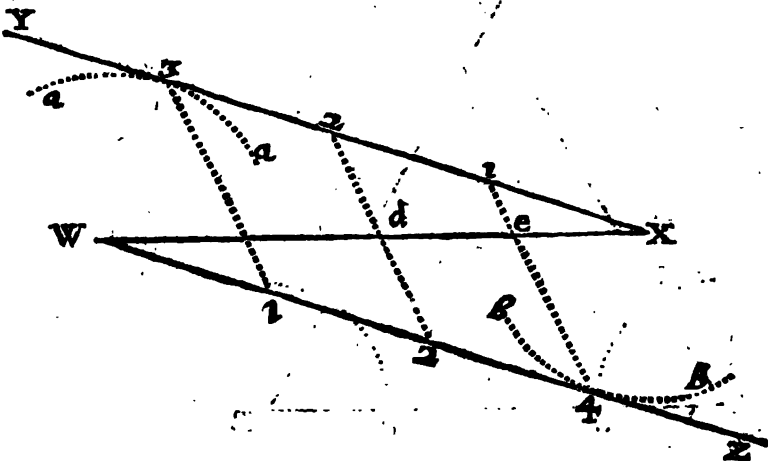

the line XY; then from W and X run the distance of your fork three times (which is one less than the number of parts into which the line is to be divided) at the points W 1, 2, and 3; and X 1, 2, and 3. Last-ly, draw the lines Y 3, 2 2, and 3 1; so shall the line WX be divided into four equal parts, in the points c, d, and e.

Another Way to do the same.

LET the given line be DE, and let it be required to divide the same into six equal parts.

First, By the following Conclusion, upon the given line DE, describe the Equilateral Triangle DEF; then with the distance of your fork run six times upon the sides FD and FE, at the points 1, 2, 3, 4, 5 G, and 1, 2, 3, 4, 5 H, and draw the line GH, upon which run also six times the distance of your fork, at the points a, b, c, d, e; then laying a Ruler upon F, and every one of the divisions a, b, c, d, e, draw the obscure lines Fa, Fb, Fc, Fd, Fe, which extended, will divide the given line DE into six equal parts, in the points 1, 2, 3, 4, 5.

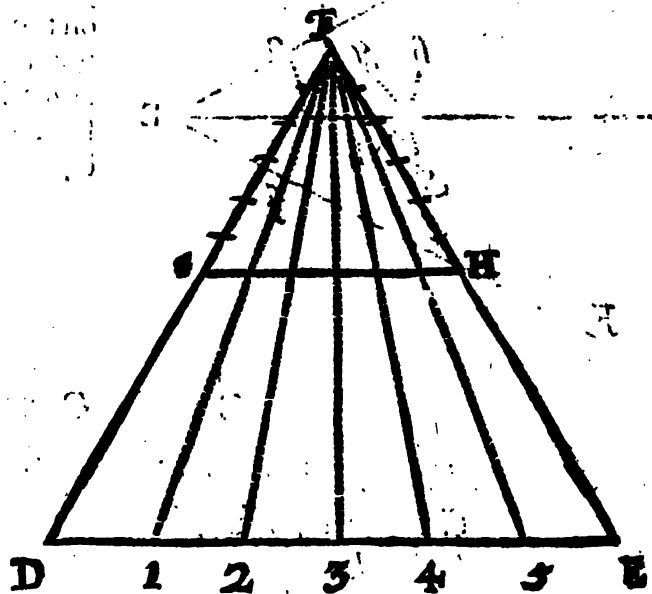

CONCLUS. VI.

Upon a Right Line given, to make an Equilateral Triangle, or a Triangle of three equal sides.

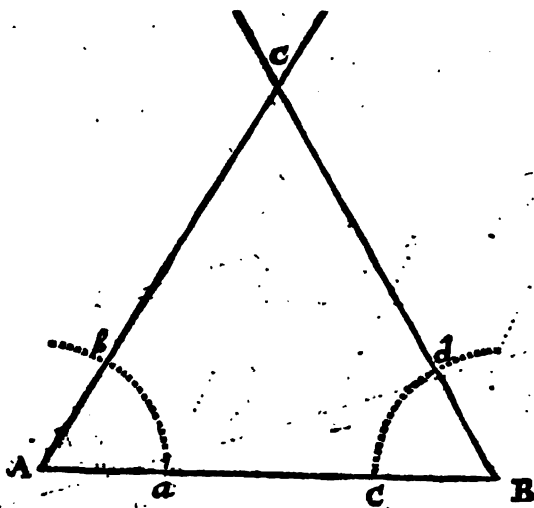

LET AB be the line given, upon the points A and B; with your fork describe two Arches, and upon them set the distance of your fork from a to b, and from c to d; then draw the two lines Ab and Bd, extending them till they concur in C; so shall ABC be an equilateral Triangle, all whose sides are equal to the given line AB.

CONCLUS. VII.

To divide a Right Lined Angle into two equal parts.

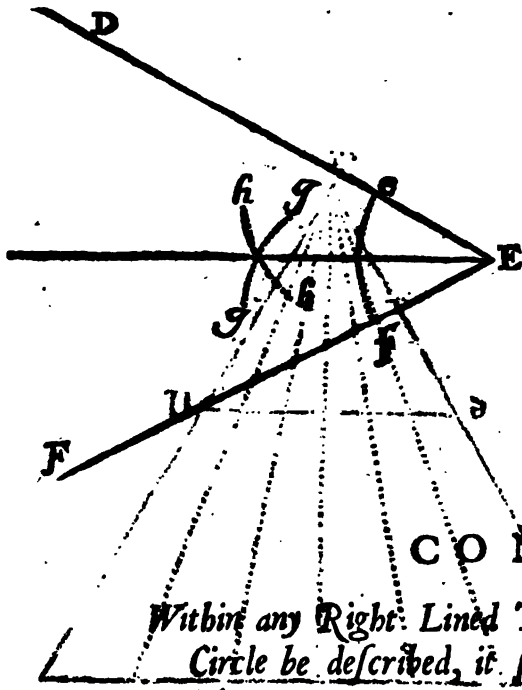

LET DEF be an Angle given, to be divided into two equal parts; upon the Angular Point E, with the distance of your fork, describe the Arch ef; and upon the point f describe the Arch gg, and upon e describe the Arch hh, crossing each other in G, draw the line EG, which shall divide the Angle DEF into two equal parts.

CONCLUS. VIII.

Within any Right Lined Triangle, to find a Point, upon which if a Circle be described, it shall justly touch all the three sides of the Triangle.

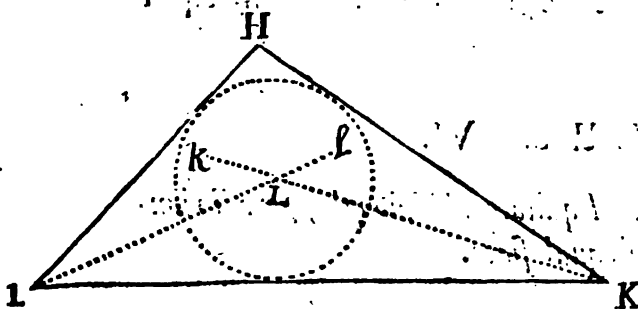

THE Triangle HIK is the Triangle given; by the foregoing Conclusion divide any two of the Angles into two equal parts, as the Angles I and K, by the Lines Il, and Kk, crossing each other in L, upon which a Circle being described, it shall touch all the sides of the Triangle HIK.

C O N C L U S. IX.

How to find a Point either within or without a Triangle, upon which, if a Circle be described, it shall touch all the Angular Points of the Triangle.

Fig. 1.

LET the Triangle given be M N O, and let it be required to find a Point, upon which a Circle being described, shall touch all the three Points M N and O.

By the second Conclusion divide any two of the sides of the Triangle, as the sides H O and M O, into two equal parts in the points P and Q; upon which points erect two Perpendiculars Q m and P n, crossing each other in R; so shall R be a Center, upon which a Circle being described, it will touch all the Angular Points of the Triangle M N O. In this case the Point R falls within the Triangle.

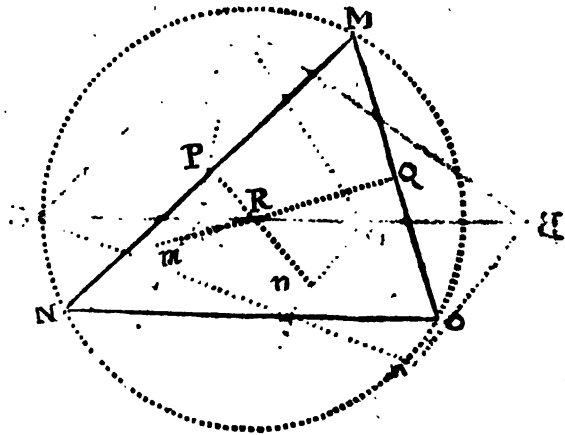
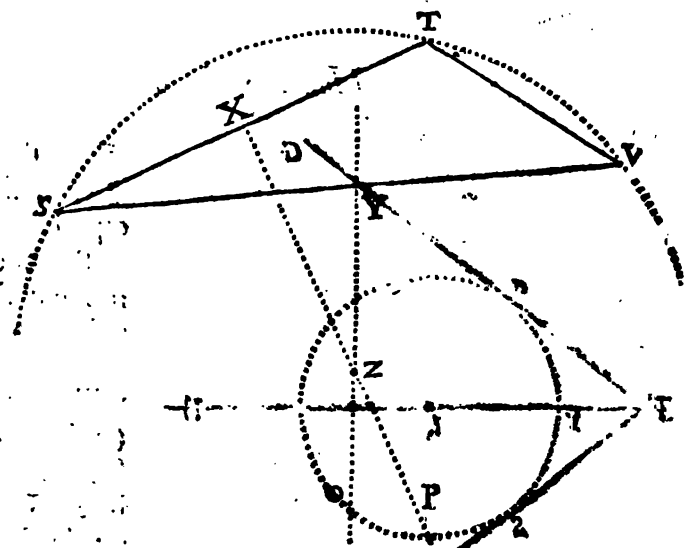

Fig. 2.

But if the Triangle had been that S T V, if the two sides thereof S T and S V had been divided into two equal parts of Right Angles, in X and Y, and from thence two Perpendiculars erected, as X p, and Y o, they would cross each other in the Point Z, without the Triangle, yet a Circle described upon that point, will pass by all the Angular Points of the Triangle.



Note, If the Triangle given be an Acute Angled Triangle, the Center will fall within the Triangle; as in the first example, Fig. 1. But if it be an Obtuse Angled Triangle, the Center will fall without the Triangle; as in the second example, Fig. 2. And if it be a Right Angled Triangle, the Center will fall in the middle of the longest side.

CONCLUS. X.

How to divide a Triangle into any number of equal Parts, by Lines drawn from any Angle thereof.

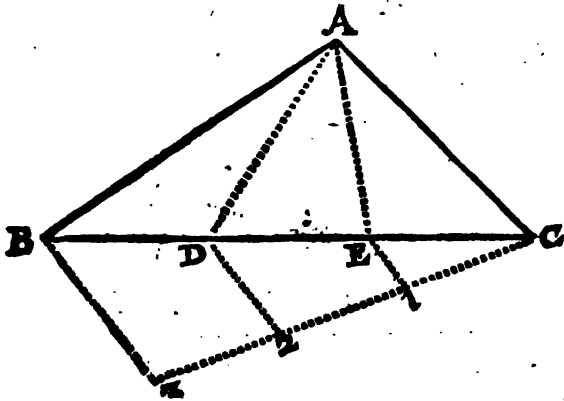

LET ABC be a Triangle given, to be divided into three Triangles by lines drawn from the Angle A.

First, By the 4th. Conclusion divide the side of the Triangle BC (which is opposite to the Angle A, from which the lines of division are to be drawn) into three equal parts in the points D and E; then draw the lines AE and AD, so shall you have three Triangles, ABD, ADE, and AEB, all of them equal one to another, and all of them together equal to the given Triangle ABC.

CONCLUS. XI.

How to make an Angle equal to an Angle given.

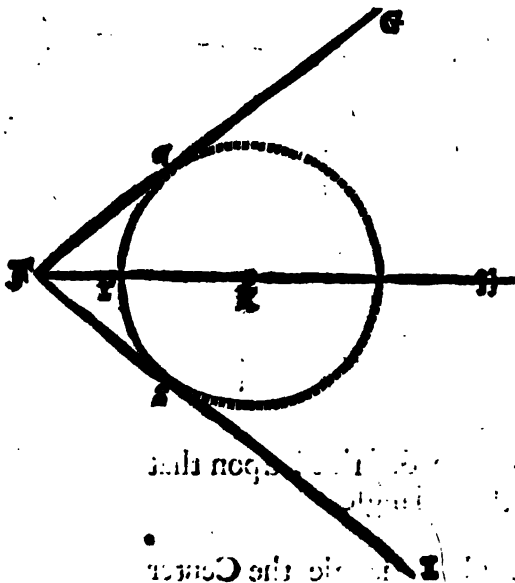

LET GFH be an Angle given, unto which it is required to make another equal.

Set one foot of your fork upon F, and move it along upon the line (or side) FH, till the other foot of the fork being turned about shall only touch the side FG, which will be at the point K: Upon K describe (with your fork) the Circle pqrs, and from the Angular Point F draw the right line FI, so that it only touch the Circle in s; so shall the Angle HFI, be equal to the Angle GFH.

CONCLUS. XII.

Upon a line given, to make a Rhombus, or Diamond-like Figure.

L E T LM be the line given ; upon which, with your fork upon the end M , describe the Arch yt ; also upon the end L describe the Arch bzv , and set the distance of your fork from y to t , from b to z , and from z to v ; and draw the lines MtN , and LZN , cutting each other in N ; then upon N , with the distance of your fork, describe the Arch ax , setting the distance thereof from a to X , and draw the line NX at length : also from L draw the line Lv , and extend it till it cuts the line Nx , being extended in O : Lastly, draw the lines NO , and LO ; so shall you have made a Rombus whose sides are all equal to the given line LM .

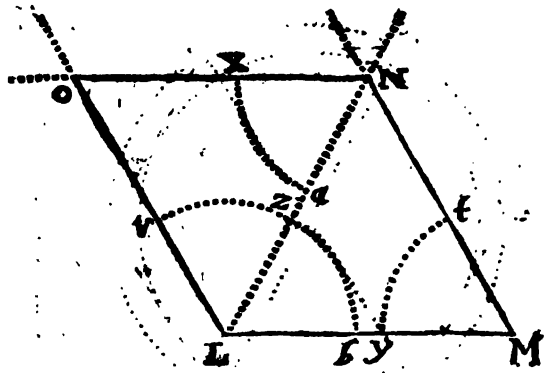

C O N C L U S . XIII.

A Circle being given, to find the Center thereof.

L E T $TPSQ$ be a Circle given, and it is required to find the Center thereof.

First, draw a right line within the Circle, to cut the Circle in two points, as the line PQ ; upon this line PQ (by the *Vth.* Conclusion) describe two Equilateral Triangles, one above, as PRQ , and another below, as PSQ ; through the points R and S draw the line $RTSV$; so shall TV be the Diameter of the Circle : Then with the distance of your fork set one foot in T , and with the other make the mark c , and setting one foot in S , make the mark d , (both in the Circumference of the Circle) ; then draw the line cd , cutting the diameter TS in X ; so is X the Center of the Circle.

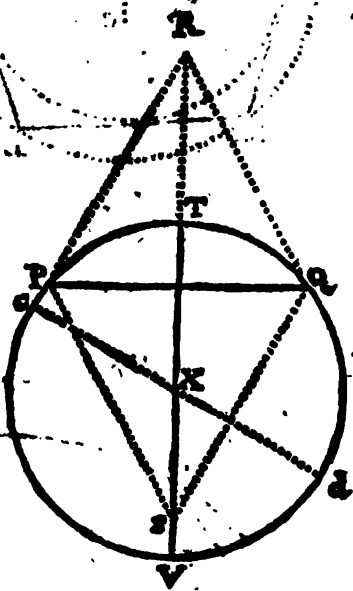

C O N C L U S . XIV.

To find a Point within a Regular Poligon, of any number of equal sides and Angles, upon which Circles may be drawn ; which Circles shall either circumscribe the Poligon, touching all the Angles thereof without ; or be inscribed to touch all the sides within.

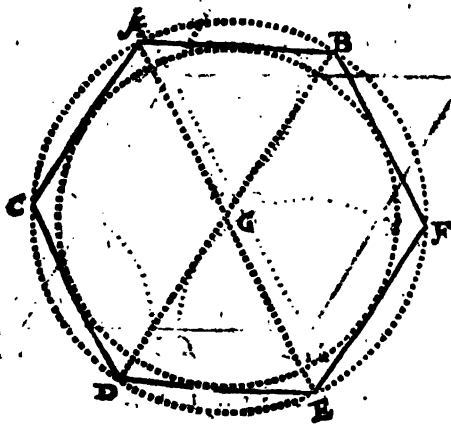

IF the *Poligon* be of an even number of sides, as 6, 8, 10, 12, &c. as the uppermost *Poligon* in the figure is of 6 sides; then you have no more to do, but to draw two lines from any two opposite sides, and their concurrence shall be the Center; as the lines A E and B D do intersect each other in the point G, which is the Center of *Poligon*, upon which a Circle may be drawn to circumscribe the *Poligon*, or one upon the same Center may be inscribed within the *Poligon*, only to touch the sides.

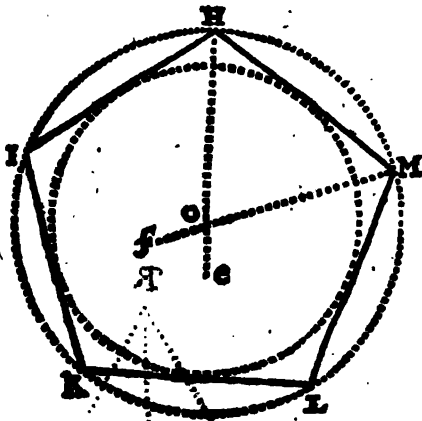

But if the *Poligon* consist of any odd number of sides, as of 5, 7, 9, &c. then (by the *Vith. Conclusion*) you must divide any two of the Angles thereof, into two equal parts, and the intersection of those lines of division shall give the Center either of the Inscribing or Circumscribing Circle about the *Poligon*; so in the lowermost *Poligon* of five sides the Angle I H M is divided into two equal parts by the line H e, and the Angle H M L is divided into two equal parts by the line M f, cutting the line H e in O; so is O the Center of the *Poligon*, upon which a Circle may be described, either to be circumscribed about, or inscribed within the regular *Poligon*.

C O N C L U S. XV.

To divide a Circle into 2, 3, 4, 6, 8, and 12 parts, or more.

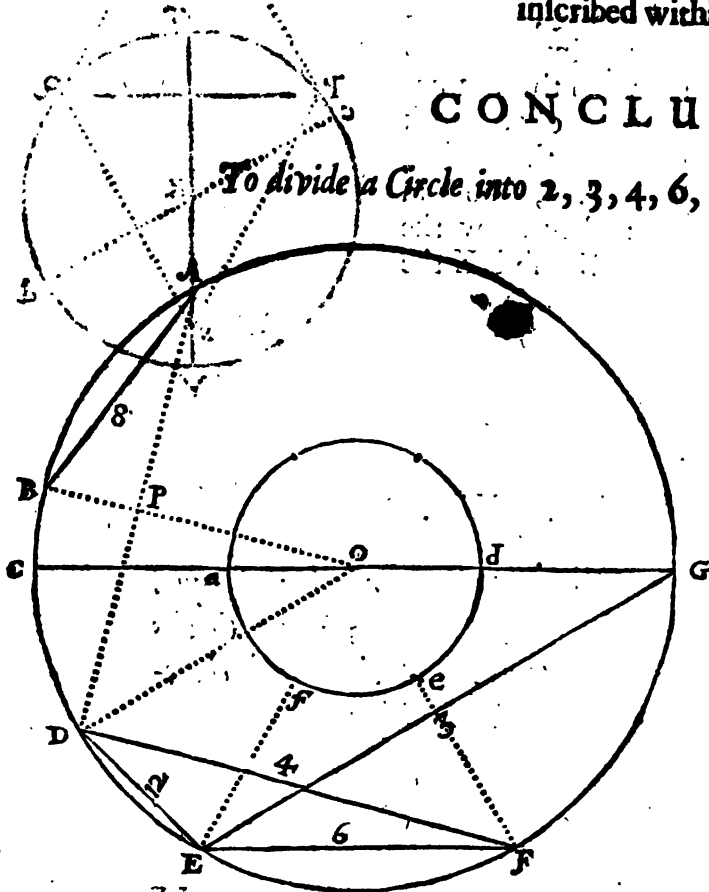

THE Circle given is A B C D E F G H; then to divide it into two equal parts you have no more to do, but to draw a line through the Center thereof, as C O G; so is the Circle divided into two equal Parts or Semicircles, C B A H G, and C D E F G. But for the dividing it into the other parts,

First, With your fork (upon the Center O) describe a Circle, dividing it into Six equal parts (which the distance of your fork will do) in the points a b c d e f; then from the Center O, through the points e and f draw the right lines O f E and O e F, between

between which draw the line EF ; which will divide the Circle into Six equal parts. Then (by the *VIth*. Conclusion) divide the Angle COE into two equal parts, by the line OD , and draw the line DE , which shall divide the Circle into Twelve equal parts. Then draw a line from E to G , as EG , which shall divide the Circle into three equal parts. Then draw a line from D to F , which will divide the Circle into Four equal parts. Divide the line DA (which is equal to DF) into two equal parts in P , and draw the line OP , cutting the Circle in B ; so shall the line BA divide the Circle into Eight equal parts.

And after this manner may the Circle be divided into several other equal parts, but not into any number.

C O N C L U S. XVI.

How with your Fork to describe a kind of Oval Figure, by once turning it about upon one Center.

TAke a piece of Paper, and lay it upon a round Ruler, or Columb of Wood or Stone (if your fork be large), and the Paper lying stretched out upon the Columb, describe thereon with your Fork a Circle, which when you have done, take the Paper from the Columb, and the Circle you there describe, will now, the Paper lying flat, appear of an Oval Form.

C O N C L U S. XVII.

How with your Fork to describe a Spherical Triangle, which shall have three Right Angles; and all the sides also equal one to the other.

UPon a point A , with the distance of your fork, describe an Arch BC ; then set one foot in B , in the former Arch, and with the other describe the Arch AC ; and lastly, set one foot in C , and with the other describe the Arch BA , so shall you have described an Equilateral Equi-angled Spherical Triangle ABC , whose Three Sides and Three Angles are all equal.

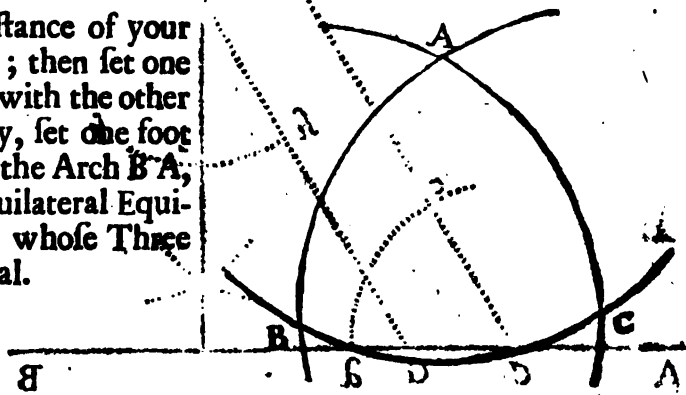

C O N C L U S. XVIII.

Through a Point given, to draw a Line which shall be Parallel to a Line given.

D

LET

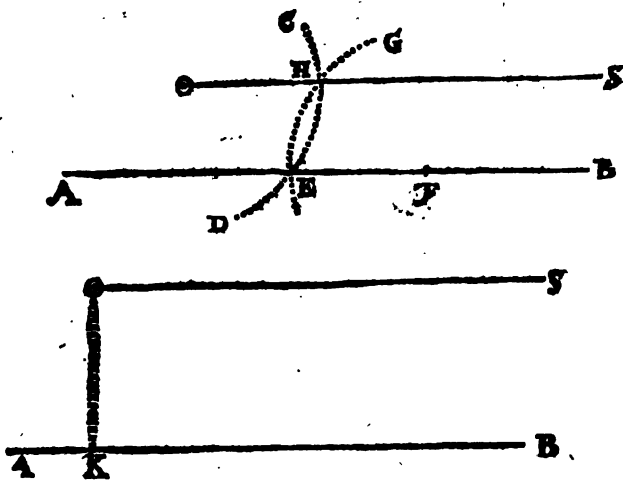

LET the Point given be \odot , through which let it be required to draw a right line which shall be Parallel to the given line A B.

First, If the distance between the Point \odot , and the given line A B, be less than the distance of your fork, then set one foot in \odot , and with the other describe the Arch C D, cutting the Line A B in the point E: then set the distance of your fork from E to F, and upon F describe the Arch E G,

cutting the former Arch D C in in H, a line drawn from \odot through H, (as \odot S) shall be Parallel to the line A B.

Secondly, But if the distance between \odot and A B be greater than the distance of your fork, then (by Concl.) let fall a Perpendicular from \odot to A B (as \odot K), and upon the point \odot erect a Perpendicular (by Concl.) to \odot K, as \odot S, so shall \odot S be Parallel to A B, as in the lowermost Scheme.

C O N C L U S. XIX.

From a Point above to let fall a Perpendicular upon a line below, otherwise than in Conclusion IV.

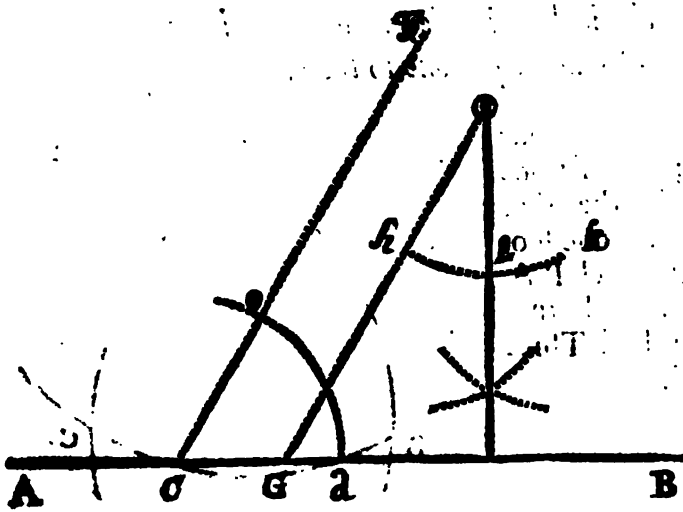

LET the given Point be \odot , from whence a Perpendicular is to be let fall upon the Line A B:

Upon any part of the line A B, as C, with your fork describe an Arch, and upon it set the distance of your fork from d to e, and draw the line C F: Then (by the last Problem) through the point C, draw a line Parallel to the line C F, as \odot G; then upon the point \odot with your fork describe an Arch, and set the distance of

your fork upon it from h to k: Lastly, (by Conclusion VI.) divide the Angle h \odot k into two equal parts in l, and through l draw the right line \odot M, which shall be Perpendicular to the Line A B.

C O N-

LET

C O N C L U S. XX.

Unto two given Right Lines, A 3, and B 5; to find a Third Line which shall be in proportion to them.

This is to perform the Rule of Three, or Golden Rule in Lines, (of which more hereafter in this Book). As if the Question were thus stated;

If 3 Yards of Cloath cost 5 Shillings;

What shall 5 Yards cost?

To perform this by this Artifice, draw two lines at length, making any Angle, as the lines D F and D H, making the Angle F D H: This done, with the distance of your fork, run three distances from D to E, upon the line D F, and 5 distances from D to G, upon the line D H, and draw the line E G; then run 5 distances (also) upon the line D F from D to F, and through F (by Conclusion XIX.) draw the line F H Parallel to E G, cutting the line D H in H; and then measuring with your fork from D to H, you shall find it to contain 8 distances of your fork, and one third part of a distance, which is 8 Shillings and 4 Pence, for the Price of Five Yards.

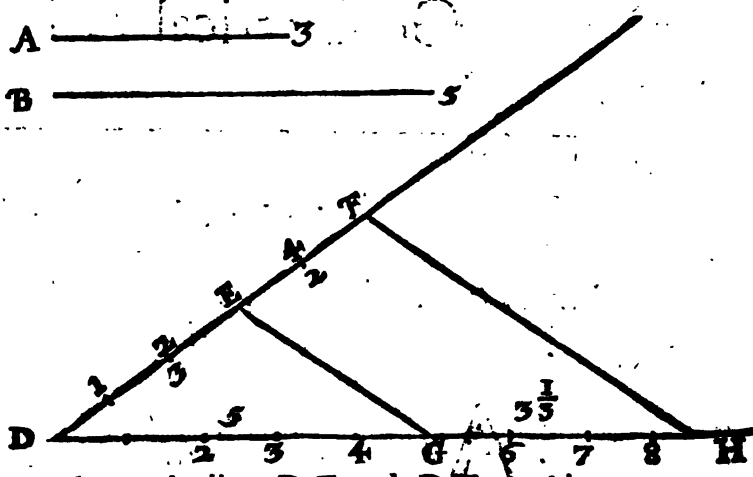

Many more of the like Conclusions may be performed by this Artifice; but for the present let these suffice.

C H A P. III.

Geometrical Arithmetick.

An Introductive Problem.

Between two Right Lines, A 4, and B 9, to find a Mean Proportional Line.

Definition. **A** Mean Proportional Line between two other Lines, is such a Line whose Length being multiplied in it self, shall produce such a Number as shall be equal to the Products of the lengths of the two given Lines, they being multiplied one by the other.

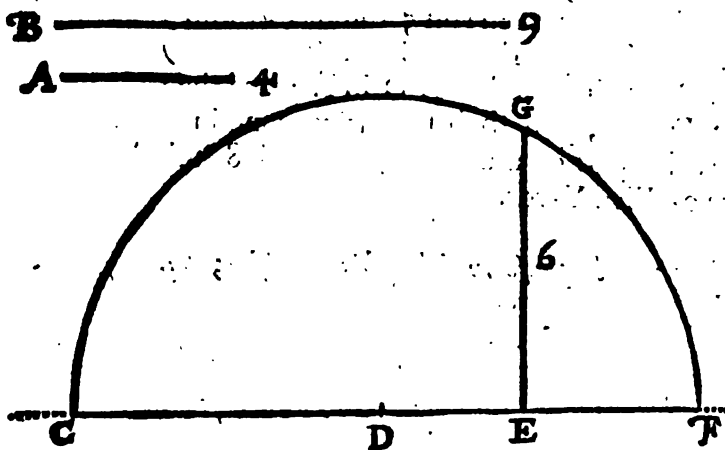

Practise. **D** Draw a Right line at pleasure, as the line C F, then take the length of the given line A 4 in your Compasses, and set it from F to B; also take the other given line B 9 in your Compasses, and set it from E to C; so is the line C F equal to both the given lines A 4 and B 9, (the point of joining them together being in the point E.) This done, divide the line C F into two equal parts in D, and upon D, as a Center, with the distance D C or D F, describe the Semicircle C G F: Lastly, from the point of joining of the two given lines A and B, namely, from the point E, erect the Perpendicular E G, cutting the Semicircle in G; so shall the line E G be a Mean Proportional between the two given Lines A and B, and will contain 6 such parts, as the whole line C F contains 13, that is, as A 4, and B 9: And so this Mean Proportional Line E G, 6, multiplied in it self will produce 36, equal to the line A 4, multiplied into the line B 9, for 9 times 4 is 36 also.

R E D U C T I O N .

I. *How to reduce a long Square or Parallelogram A B C D, into a Geometrical Square E F G D, whose four sides are all equal.*

BY the Problem foregoing find a Mean Proportional Line between A B the shorter, and B D the longer side of the long Square A B C D, which will be found to be D F.

First, Draw a line as B H, and upon it set one of the longest sides of the Parallelogram, as A C, from B to D; also take the shortest side A B, and set that from D to H; and upon the point of joining at D, erect Perpendicular: Then divide the line B H into two equal parts in K, and upon K (as a Center) describe the Semicircle B F H, cutting the Perpendicular D F in F; so shall D F be the side of the Geometrical Square, G E F D, which shall be equal in quantity to the long Square A B C D.

For,

Suppose the lesser side of the Long Square A B to be 8 (of any measure) and the longer side A C to be 18, the Mean Proportional between them F D will be 12; and so 18 multiplied by 8, the Product will be 144; and so will 12 multiplied by 12, produce the same.

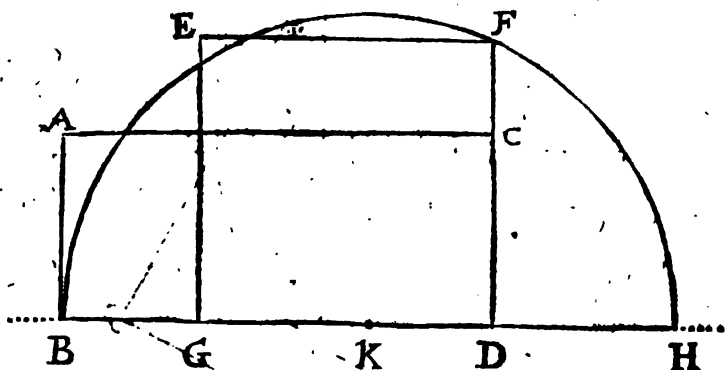

II. *To Reduce a Triangle into a Geometrical Square.*

LET L M N be a Triangle given to be reduced into a Square.

Draw a line at pleasure, as L R, then take the length of the Base of the Triangle L N, and set it from L to N; then take half the length of the Perpendicular P O, and set it from N to R, and upon N erect the Perpendicular N Q; then divide the line L R into two equal parts at S, and upon S as a Center, with the distance S L or S R, describe the Semicircle L Q R, cutting the Perpendicular N Q in Q; so shall Q N be the side of a Geometrical Square, equal to the Triangle M L N.

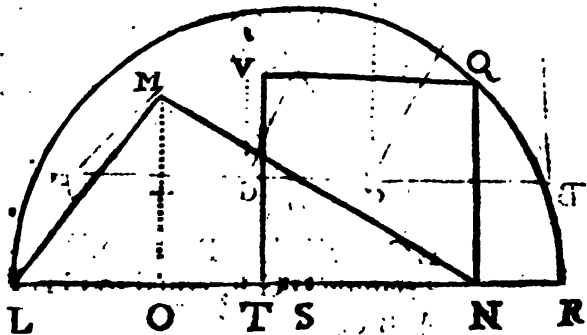

III. *To*

III. To Reduce a Circle into a Geometrical Square.

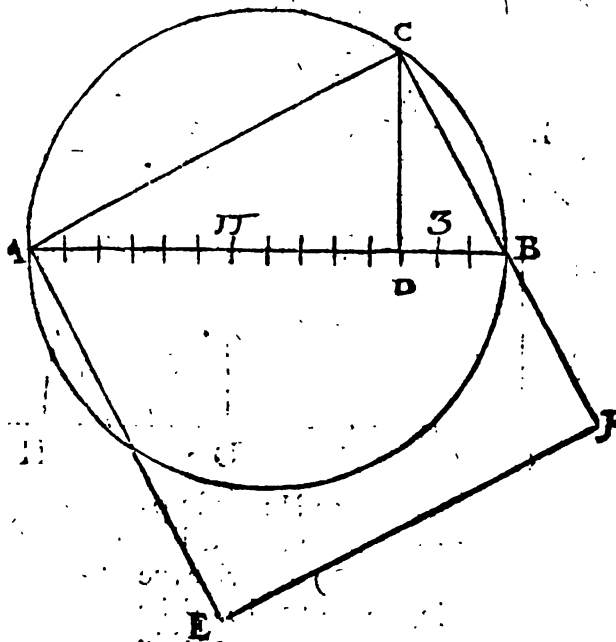

LET ABC be a Circle given to be reduced into a Geometrical Square.

Divide the Diameter of the Circle AB into 14 equal parts, at 11 of them, as at D, erect a Perpendicular DC, cutting the Circumference in C; then draw the line AC, which shall be the side of a Square ACEF, equal to the Circle ABC.

IV. Two Triangles of different heights being given, to reduce them to one height.

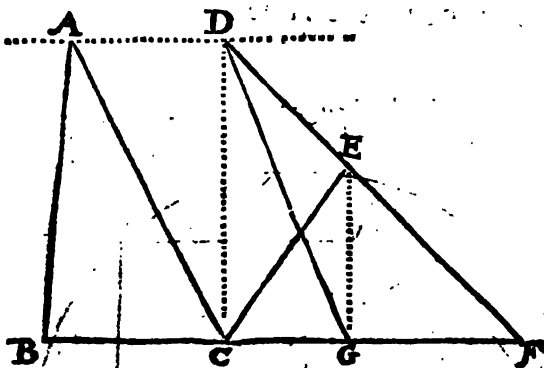

LET there be two Triangles ABC, and CEF, and let it be required to reduce the Triangle ECF into another Triangle that shall be equal in height with the Triangle ABC.

First, Through the point A draw a line AD, parallel to the bases of the two Triangles, viz. BF; then extend the side EF of the Triangle CEF, till it cut the Parallel line in D, and draw DC; then through the point E draw the line

EG parallel to DC. Lastly, draw the line DG, so shall you have a new Triangle DGF, equal to CEF, and of equal height with the Triangle ABC.

V. How to Reduce an irregular Figure of Four sides into a Triangle, from an Angle given.

LET HKLN be a *Trapezium*, or a Figure of Four unequal Sides and Angles, and let it be required to reduce the same into a Triangle, by a Line drawn from the Angle N.

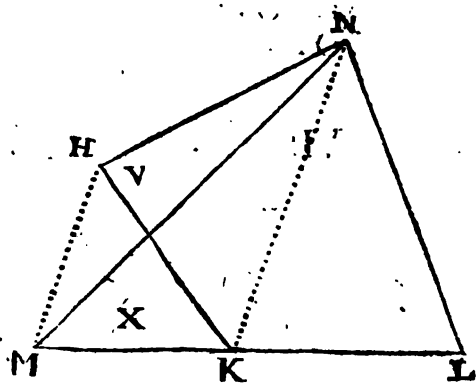

Extend the side KL, which is opposite to the Angle N, towards M, and from N draw a line to the opposite Angle M, as NK; then through the point H draw the line HM parallel to NK: Lastly, draw the line NM; so shall you have a Triangle LMN, equal to the irregular Figure HKLM; for the Triangle V, left out in the irregular Figure, is equal the Triangle X, which is taken into the Triangle.

VI. To reduce an irregular Figure of Four sides into a Triangle, by a line drawn from a Point limited in any of the sides thereof.

LET ABCD be an irregular figure, and it is required to reduce the same into a Triangle, by lines drawn from the point E, in one of the sides thereof.

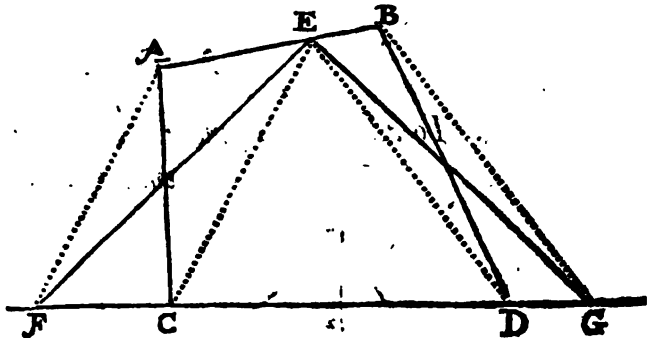

From the given Point E draw two lines to the two opposite Angles, as the lines EC and ED, and extend the side CD, opposite to the given point E, out on both sides towards F and G; then through the point A draw the line AF, parallel to EC, and the line BG parallel to ED, cutting the side CD (extended) in the Points F and G: Lastly, draw the two lines EF and EG; so shall you have a Triangle EFG, equal to the irregular figure ABCD.

VII. To Reduce an irregular figure of Five sides, into a Triangle, by lines drawn from any of the Angles thereof.

LET OPQRS be the figure given, and let it be required to Reduce it into a Triangle, by lines drawn from the Angle at O.

First, Prolong the side QR, opposite to the given Angle at O, both ways, towards T and I; and from the Angle O draw the lines OQ and OR; also through the Angular point P and S, draw the lines PT and SI, parallel to OQ and SR, cutting the side QR (extended) in the points T and I: Lastly, Draw the lines OT and

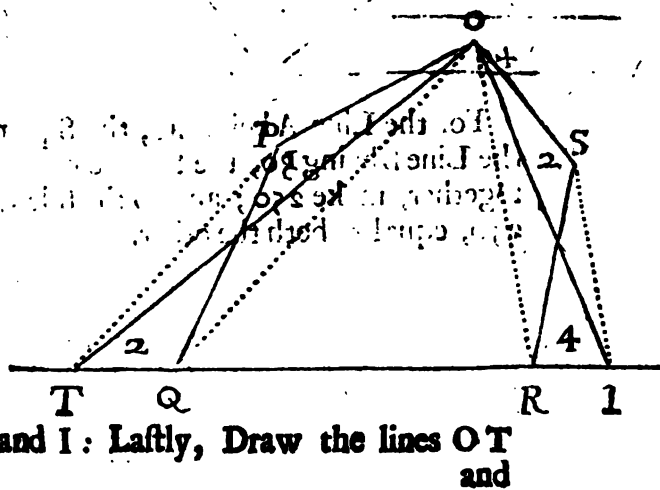

and OI; so shall you have a Triangle O T I, equal to the five sided figure O P Q R S.

VIII. To Reduce a Geometrical Square into a Figure of a Lunary Form.

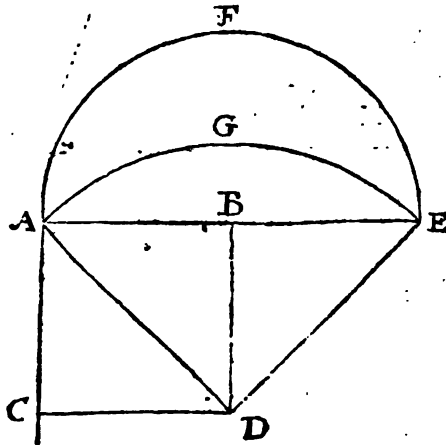

LET ABCD be the Square given; first draw the Diagonal line AC, and on the end thereof at C erect the Perpendicular EC, making it equal to AC; then continue the side of the Square AB to E; and on B, as a Center, with the distance BA or BE, describe the Semicircle AFE. Lastly, On the point C, and distance CA, describe the Arch AGE, leaving the Lunary Figure AFEG, equal to the Geometrical Square ABCD.

A D D I T I O N.

I. To add two Geometrical Squares together, and to give the Sum of them together in one Square.

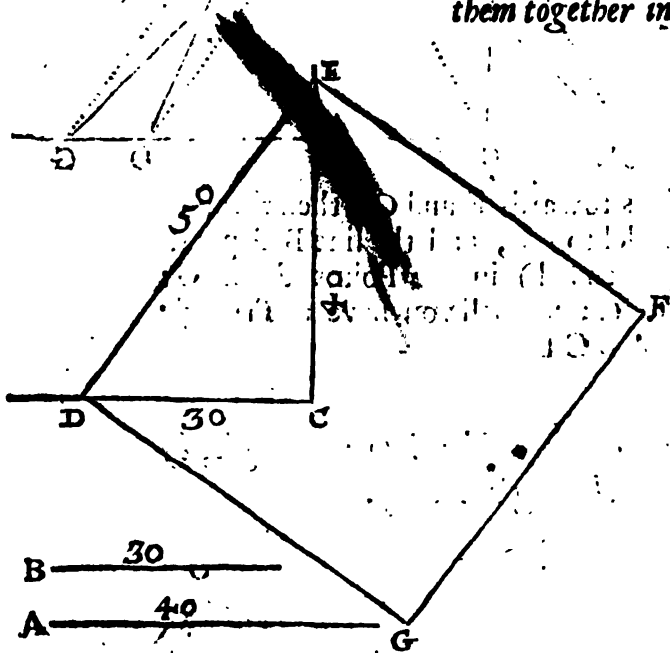

LET the two lines A and B be the sides of the two Geometrical Squares; the one being 30, the other 40, of any Measure.

First, Join two lines DC and EC together, making a right angle at C: Then take the line B in your Compasses, and set it from C to D; also take the line A in the Compasses, and set that from C to E, and draw the line ED, so shall ED, be the side of the Square DEFG, which shall be equal to both the Squares made of the lines A and B.

For the Line A being 40, the Square made thereof will be 160; and the Line B being 30, the Square made thereof will be 90; which added together, make 250; and so the side ED being 50, the Square thereof is 250, equal to both the other.

II. To

TO find the sum of two Squares, and to give the Sum of them together in one Square.

II. To add Two, Three, or Four Squares together, and to give their Sum in one entire Square.

LET HIKL be four lines given, equal to the sides of four several Squares.

First, Join two lines MN and NO together, so as to make a right Angle at N; then take the line L, and set it from N to P, and take the line K, and set it from N to Q, and draw the line QP, which shall be the side of a square equal to the squares of L and K. — Then take the line QP, and set it from N to V, and the line I and set it from N to R, and draw the line RV, which shall be the side of a square, equal to the squares made of the lines L, L and I. — Then take the line RV, and set it from N to S, and the line H, and set it from N to T, and draw the line ST, which is the side of the square STXY, and is equal to the four squares made of the lines H, I, K, and L; which I thus prove by Numbers.

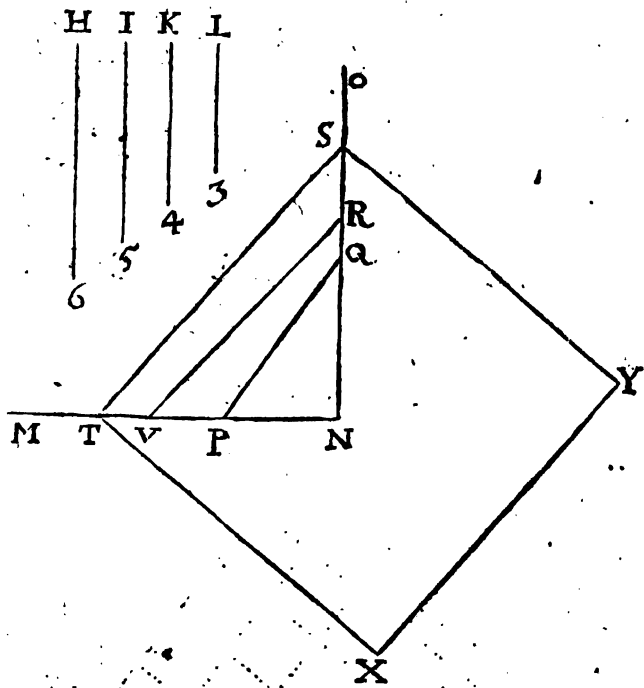

The Line	}	H	is	}	6	Whose	}	36.	
		I			5			Square is	25.
		K			4				16.
		L			3				9.

Their Sum is 86.

And the Square Root of 86 is $9\frac{27}{100}$, and somewhat more, for $9\frac{27}{100}$ multiplied in it self, produceth for its Square $85\frac{93}{100}$, which is too little; and the Square of $9\frac{28}{100}$ will be, $86\frac{12}{100}$, somewhat too much.

III. To add two (or more) Circles together.

LET the lines A and B be the Diameters of two Circles to be added together.

Make a right Angle by the two lines CD and ED; then take the line A, and set it from D to F, and take the line B, and set it from D to G, and draw the line GF, which shall be the Diameter of a Circle equal in Area or Content of two Circles described upon the Diameters A and B.

In this manner may you add Three, Four, or more Circles together.

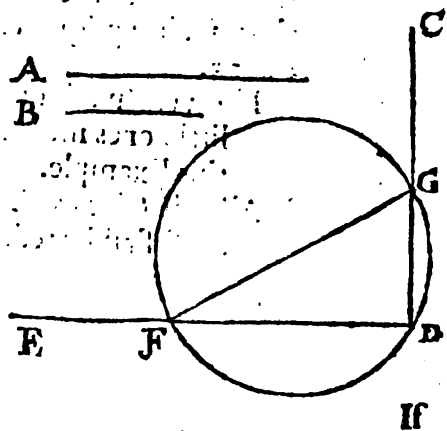

E

IF

R E C R E A T I O N S

If you would add 2, 3, 4, or 5 Triangles together, you must first reduce them to Geometrical Squares, and then add them; as before is taught.

Also if they be Long Squares or Parallelograms, first reduce them to Geometrical Squares, and then add them.

If the figures to be added be of divers kinds, as a Long Square, a Circle, a Triangle, an Irregular Figure of four or five sides, you must then first reduce your figures of 4 or 5 sides into Triangles, and those Triangles into Geometrical Squares, and then add them, as hath been already taught.

S U B S T R A C T I O N.

I. *Two Geometrical Squares being given, to subtract the Lesser from the Greater, and to give the Remainder in a third Square.*

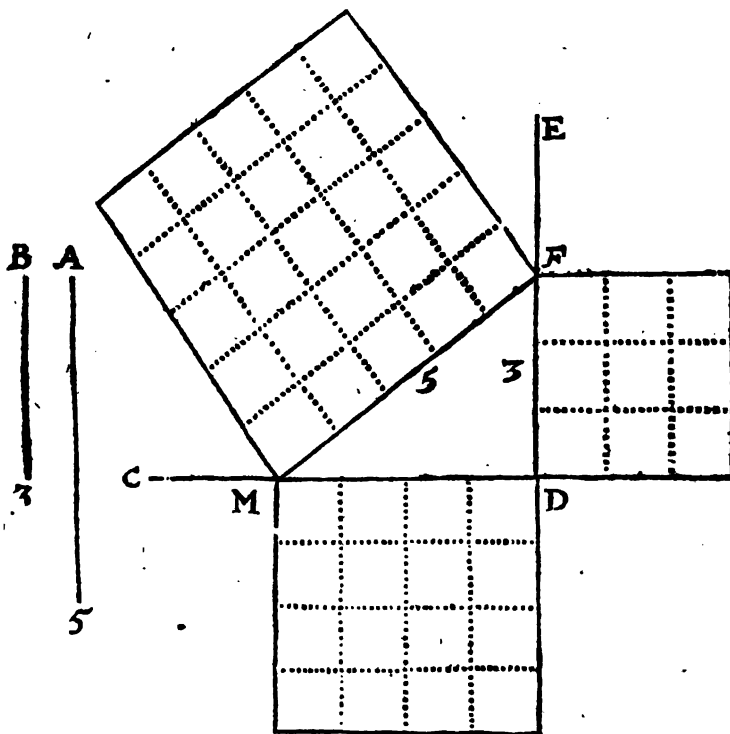

L E T A and B be the sides of two Squares, and let it be required to subtract the square of B from the square of A.—First, Join two right lines, C D and E D in a right Angle in D; then take the lesser line B, and set it from D to F; then take the greater line A, and setting one foot of the Compasses in F, with the other mark the Point M in the line C D, and draw the line F M.

Then have you a Triangle F M D, of which the side D M, equal to the line B, is 3, and the square raised thereon contains 9 little squares; and the side M F equal to the given line A,

which is 5, and the square raised thereupon contains 25 little squares; then subtract the square 9, from the square 25, and there is left 16 for the remaining square, for 4 times 4 is 16, as 3 times 3 is 9, and as 5 times 5 is 25.

If divers small squares be to be subtracted from one greater square, the little ones must be all reduced into one, and then subtracted, as in this Example.

Also, if Circles, Triangles, or other figures be to be subtracted, they must first be reduced, and then dealt with as before.

MUL-

M U L T I P L I C A T I O N.

Multiplication in Geometry, is nothing esse but to find the Square that is made of any Line (or Number) multiplied in it self. Or to find the Rectangle or Parallelogram made of any two Lines or Numbers involved one into the other.

Example 1. *Let the Number 12 be given, to be multiplied in it self.*

Now 12 multiplied in it self (that is, by 12) produceth (or the Product is) 144; so that 144 is the Square, and 12 the Root thereof. And so of any other single Number in it self produceth a Square Number.

Example 2. *Let there be two Numbers 8 and 3 to be multiplied together.*

Now if you multiply 8 by 3, the Product is 24, which in Geometry is called a Rectangle, and 24 is the superficial Content or Area thereof, and 8 and 3 are the two sides thereof.

Which in Geometrical Figures will be as follows ;

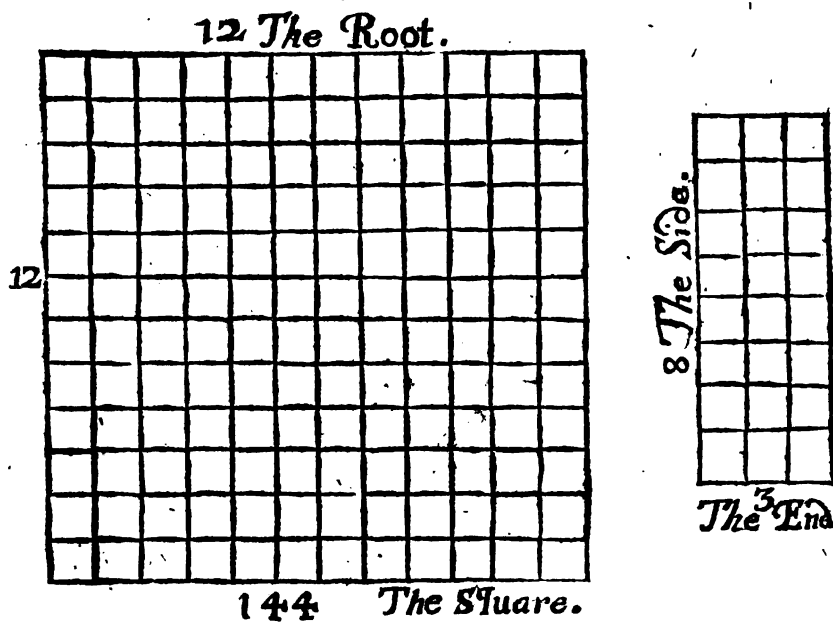

DIVISION.

I. To divide a Triangle into any number of equal parts, by Lines drawn from any Angle thereof.

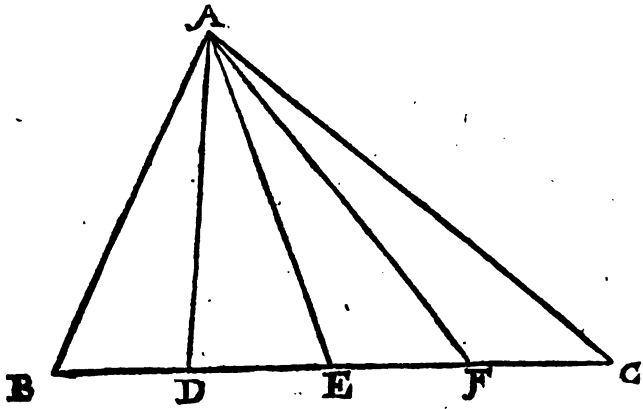

and AFC , all of them equal one to another, and all of them together equal to the given Triangle ABC .

LET ABC be a Triangle to be divided into four equal parts, by lines drawn from the Angle at A .

First divide the side BC , which is opposite to the Angle A , (from whence the division is to be made) into four equal parts, in the points D , E , and F ; then if you draw the lines AD , AE and F , you shall have four Triangles ABD , ADE , AEF ,

II. To divide a Triangle into any number of equal parts, by lines drawn from any Point taken in any of the Sides thereof.

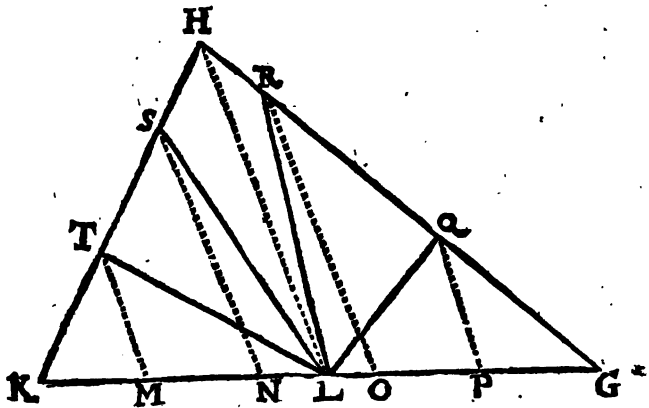

LET GHK be the Triangle to be divided into five equal parts, by Lines drawn from the Point L in the side KG .

First, divide the side GK , in which the point of division is, into five equal parts, in the points M , N , O , and P ; and from the point of division at L , draw a right line to the opposite Angle H ; then through the several Points M , N , O , and P , draw lines all parallel to the line LH , as the lines MT , NS , OR , and PQ ; by which the whole Triangle is divided into five equal parts.

III. How

III. *How to divide a Triangle into Two, Three, or Four, (or more) unequal parts.*

LET the Triangle A B C be a Piece of Ground containing Nine Acres, and it is let out to four men; A B C and D, of which A is to have 3 Acres, B 2 Acres, C 1 Acre about the middle, and D 3 Acres, and their lines of separation are to be made from the Angle at A, there being a Pond to accommodate all the Tenants.

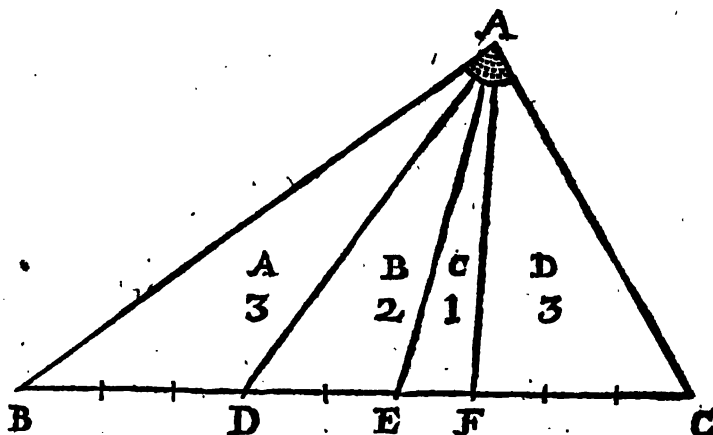

First, Divide the side B C, which is opposite to the points from whence the division is to be made, into 9 equal parts; then (because A is to have 3 Acres) count three of the parts (or divisions) from B to D, and draw A D, so is A B D 3 Acres, the share for A. — Then count two parts more from D to E, and draw E A, so is A D E 2 Acres for B. — Then count one division from E to F, and draw A F; so is E A F one Acre for C his share; and the rest, F A C, being three Acres, is the share for D; in all, Nine Acres.

IV. *How to divide a Triangle into two or more equal or unequal parts, by a Line drawn Parallel to any side thereof.*

LET GHK be a Triangle given, to be divided into two equal parts, by a line drawn Parallel to any one side thereof, as the side G K.

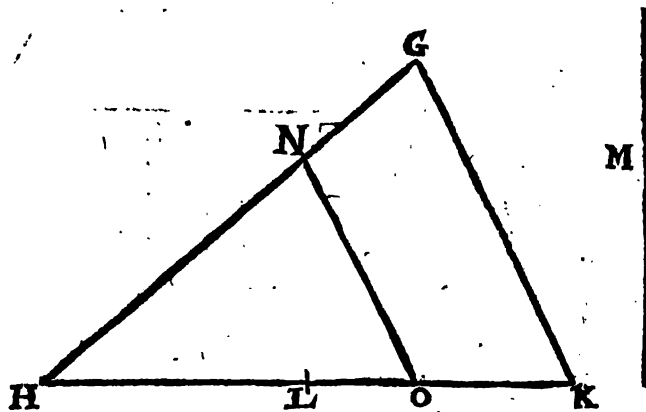

First, divide the side K H into two equal parts in L; then by the Introductory Problem find a Mean Proportional Line between the whole Base H K and H L, which line will be found to be the line M, which line M set from H to O, and through O, draw the line O N, parallel to G K; so shall the Triangle be divided into two equal parts, by the line N O.

The G O L D E N R U L E,

Or *Rule of Three.*

TO work the Golden Rule, or Rule of Three, Geometrically, is, by having of Three Lines (or Numbers) given, to find a Fourth Line (or Number) that shall be in Proportion to them; that is,

As the First Line (or Number)
Is to the Second Line (or Number),
So is the Third Line (or Number)
To a Fourth Line (or Number).

Therefore,

Having Three Lines (or Numbers) given, let it be required to find a Fourth that shall be in Proportion to them.

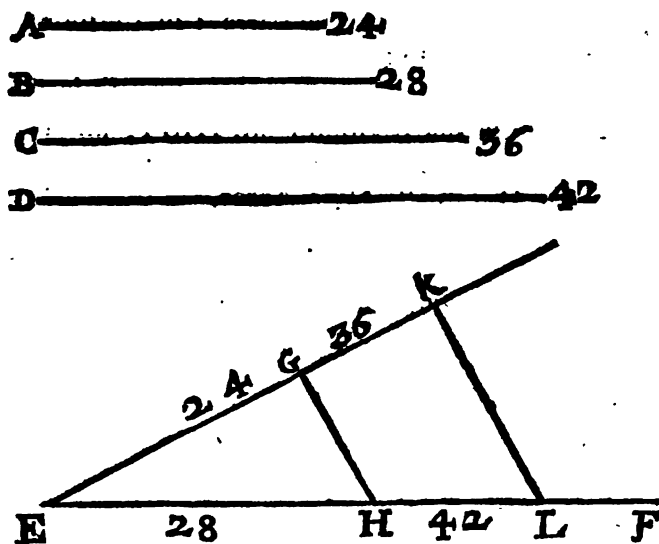

LET the Three Lines given be A 24, B 28, and C 36, of any Measure), and let it be required to find a Fourth Line D, which shall be in Proportion to them.

First, Draw two lines, as E M and E F, making any Angle, as the Angle D E F; then take the line A in your Compasses, and set it from E to G; then take the line B, and set it from E to H, and draw the line G H; then take the third line C in your Compasses, and set that from E to K, upon the line E M, the same where the first line A was set; and through the point K draw the line K L Parallel to G H, cutting the line E F in the point L; so shall the line E L be the Fourth Proportional Line required.

For,

For,

As the Line A, equal to E G 24,
Is to the Line B, equal to E H 28;
So is the Line C, equal to E K 36,
To the Line D, equal to E L 42.

And so,

If 24 Yards of any Commodity cost 28 Shillings; what shall 36 Yards of the same cost at that rate?

Thus, as in Vulgar Arithmetick, if you multiply the second number 28, by the third number 36, and divide the Product by the first number 24, the Quotient will be 42 for the fourth number sought; and so many Shillings will 36 Yards cost.

C H A P. IV.

Of Altimetria, Longimetria, and Planometria.

Shewing how to take all manner of *Heights, Depths, and Distances*, whether Accessible or Inaccessible, and to *Measure Land Mechanically*.

SECT. I. *Of Altimetria, or Measuring of Heights.*

P R O B L. I.

How to take the Height of any Tree, Steeple, or other Upright Building, by the Shadow thereof.

F I G. I.

LET AB be the Wall of some Castle or Watch-Tower, and the Sun shining casts the Shadow thereof upon the Level Ground to C; now having a Walking staff in your hand, set that upright at the end of the shadow of the Wall at C, and I find that the staff casts its shadow to E, where I make a mark, as also another at C; then measuring the length of my staff, I find it 38 Inches, and the length of the shadow of it CE, to be 46 Inches: Then measuring the length of the shadow of the Wall of the Tower AC, I find that to be 30 foot, which is 360 Inches. Now for the Height of the Castle-Wall, you must work by the Rule of Proportion, thus:

As CE, the length of the shadow of the staff, 46 Inches,
Is in Proportion to the length of the staff CD, 38 Inches;
So is AC, the length of the shadow of the Wall, 360 Inches;
To 297.4 Inches, for the Height of the Castle Wall.

For

For if you multiply 360, by 38, the Product will be 13680; which divided by 46, the Quotient will be 297.4 Inches *ferè*, for the Height of the Castle-Wall B A, which is 24 Foot and 9 Inches, and somewhat more.

P R O B L. II.

How to take the Height of a Watch-Tower, by the Shadow, when you cannot come to the bottom of it, to measure the length of the Shadow.

F I G. II.

LET A B be a Watch-Tower, whose Height I would know by the shadow thereof, but there is a Moat about it, as B C, so that I cannot come to measure the shadow thereof: However,

I come near to the Moat-side, and there I find the shadow of the top of the Tower, to cast at C, where I erect my staff C G, and that casts its shadow to H; I measure the length of my staff, and I find it 4 foot, or 48 Inches; and the length of the shadow thereof C H, I find to be 32 Inches, these two I note down.

Then, some time after, (when the Sun is lower) I come again to the place, and find the shadow of the top of the Tower to cast at D, where again I erect the same staff of 4 foot long, and find that it casts its shadow to E, and that the length of the shadow thereof, D E, is 4 foot 5 inches, or 53 inches, and somewhat better; this I also set down, and then I measure the distance between the two places where the Tower casts its shadow, at the first and second time of my observation, namely the distance C E, and find it to be 10 foot, or 120 inches.

And now having all these numbers set down, I come to find the Height of the Tower A B, by help of the Rule of Proportion, as followeth.

(1.) As D E, the length of the shadow of the staff D F at the second Observation, 53 Inches,

Is to 48 Inches, the length of the staff;

So is 10 foot (or 120 Inches) the length of the shadow between the two places of Observation C and D,

To 108 Inches, or 9 foot.

Which number 9 foot, or 108 Inches, set down,

And say again by Proportion,

(2.) As 48 Inches the length of the staff G C,

Is to 10 foot (or 120 Inches) the distance between the two places of Observation C and D;

So is 108 Inches, (the Number before found)

To 270 Inches, the Height of the Tower; which reduced into Feet is 22 Foot, 6 Inches.

P R O B L. III.

How to take the Altitude of any upright Building, or the like, by a Bowl of Water.

F I G. III.

Travelling along the Road I see a May-pole, as K L, the height whereof I would gladly know, but having no Geometrical Instrument, I procure a Bowl of fair Water, which I set down upon the ground,

ground at M. And then, when the Water is still in the Bowl, I go backward in a right line from the May-Pole, till I see the shadow of the top of the May-Pole in the middle of the Water, which I do when I come at N; and at N, I make a mark upon the ground; then do I measure the distance from the foot of the May-Pole at L, to the Bowl of Water at M, and find it to be 175 Inches: Also I measure the distance from the Bowl of Water at M, to the place of my standing at N, and find that to be 72 Inches: Then I measure the Height of my eye from the Ground O N, and find that to be 60 Inches: These things known, I say by the Rule of Proportion,

If 72 Inches distance M N, give 60 Inches Altitude N O;

What Altitude shall 175 Inches the distance L M give?

Answer 145 $\frac{60}{72}$ Inches.

For if you multiply 175 by 60, the Product will be 10500, which divide by 72, the quotient will be 145 $\frac{60}{72}$, that is almost 146 Inches, which is 12 foot 2 Inches for the height of the May-Pole K L, required.

P R O B L. IV.

How to take the Height of any upright Building that is approachable, by two Sticks or Rulers joined together Square-wise.

F I G. IV.

LET P Q be some Structure, standing upright upon plain Ground, whose height you require.

Go unto some convenient Court, Yard, Garden, or other piece of level Ground adjoining to the building to be measured, then take your Square in both your hands, holding it perpendicular, which you may do, by having a Thread and Plummets as T V, hung upon a pin near the top of the Square at T; then keeping it in this posture, go backwards or forwards (as occasion requires) till your Eye being at X, you can see the other end of your Square at T, and the Top of the Building at P, all in one Right Line, which when you do, make a stand, as at S; Then measure the height of your eye from the Ground X S, with a string, and set that length upon the ground from the place of your standing at S, to R: Then measure the distance from R to Q, for that shall be equal to the height of the building P Q, and is here 210 foot.

S E C T. II.

Of Longimetria; or Measuring of Distances.

P R O B L. I.

How by the help of this Square, standing upon a Platform of a known height, to find the distance from the Platform to any Tree, River, or other Object that is remote from you.

F I G. V.

LET A B be a Platform, whose Perpendicular height is 100 foot, being upon the top thereof at A, I would know how far the Oak at C, is distant from the bottom of the Platform at B.

Upon the top of the Platform at A, I erect a Pike or Javelin 12 foot long,

F

long, more or less, upon which I hang the Angle of my Square: And I look with my eye at D, along the side of my Square, till I see the bottom of the Oak at C, and in this position I fix my Square, with a Screw or the like, to the head of the Javelin: Then from D I extend a thread or Line by the side of my Square, till it touch the Platform at E, and then I measure the distance upon the Platform from A to E, and find it to be 24 foot, 6 inches; then by Proportion I say,

As 12 foot, the length of the Javelin, D A,

Is to 24 foot and a half, the distance measured upon the Platform A E,

So is 112, the height of the Platform and Javelin together, B D,

To 228 foot, 8 inches, for the distance B C.

P R O B L. II.

How to take the distance from the place of your standing upon level Ground, to any Tree, Tower, or other thing, remote from you, tho you cannot come near the same, by your Square.

E I G. VI.

Standing at F, I see a Conduit head at G, whose distance from F where I stand, I would know, but I cannot come near it for a River between F and G: However,

At F I erect a staff of 4 foot high, (or 48 Inches) as F H, upon the end whereof I hang the Angle of my Square, and I look by the side thereof, till I see the foot of the Conduit-head at G, and fixing my Square there, I extend a line from H, by the side of the Square, till it touch the Ground at K: Then measuring the distance between F and K, I find it to be 3 foot, or 36 Inches: Then by the Rule of Proportion I say,

As 36, the distance K F,

Is to F H, the length of the staff, 48 Inches;

So is 48 inches, the length of the Staff F H,

To 64 inches, for the Distance F G.

For as often as K F is contained in F H,

So often is F H contained in F G.

P R O B L. III.

How to take the Breadth of a River by the Square.

F I G. VII.

There is a River M P O, whose breadth I desire to know: Upon the brow of the River at M, I set up my Staff M L, which is 60 inches (or 5 foot) long, and hanging my Square upon the end thereof at L, I look by the side thereof, till I see the Brow of the River on the other side at O, and there fixing my Square, I extend a Thread by the side thereof, from L to N, then measuring the distance L N, I find it to be 15 inches (or 1 foot 3 inches); then I say by Proportion,

As N M, the distance measured, 15 inches,

Is to L M, the length of the Staff, 60 inches.

So is L N 15 inches,

To M O, 240 inches, (or 20 foot) for the breadth of the River M O.

P R O B L.

P R O B L. IV.

How to take an inaccessible Distance, by three flat Sticks or Rulers of equal Length, joined together, thereby making an Equilateral Triangle: As in

F I G. VIII.

LET A be a Tree or other Object, whose distance you would know from the place of your standing at B, there being a River or the like Impediment between you and the Tree.

Place your Triangular Rulers horizontally upon a staff at B, and observe the Object at A by the side of the Triangle B D ; it so resting, look at some other Object (or cause one to be set up) by the side of the Triangle B E. Then transfer your Triangle along the line B C, and place it upon divers parts of the same line, till at length you find a Point C, upon which placing the Triangle, you shall see the Point B, by the side C G, and the Object A, by the side C F ; then I say the lines C B and C A are equal ; so that by measuring the line B C, you have the Distance from B to A.

P R O B L. V.

How to take the Distance between Two (or more) Places, without coming near any of them, by a Two Foot Joint Rule.

F I G. IX. and X.

LET the two remote Places given be A and B, whose distance I would know, but I cannot approach or come near either of them ; and I have no other Instrument but my Two-Foot Joint Rule ; however, I make choice of a Place at C, from whence I can see both the Places, A and B, and there I set up a staff whereon to rest my Rule, and opening it to a Square Angle, I look by one side of it, till I espy my first place at A, and there keeping it fast and level, I look by the other side of the Ruler, and cause a Mark to be set up in a right Line from C, at a competent distance from C, as at D, 150 foot ; then close in your Rule, till by the side thereof you see your second place at B ; keep your Rule at that Angle :

Then having a sheet of Paper, or upon a Board, as Figure IX. draw two Right Lines thereon, as K L, and L M, making a Right (or Square Angle) at L.

Then bring your Ruler, (it being still kept at the Angle it was when you looked to B) and lay the Center of your Ruler upon L, and by the side of it draw a line L M ; and because your measured distance between C and D was 150 foot. take 150 quarters of Inches (150 of any equal parts that you have upon your Ruler) and set them down upon your Paper or Board, from L to M.

Then take your Rule and go to D, and set the Center of it upon the Staff, look by one side thereof to C, and by the other to A, then bring the Rule to the Board, and lay the Center thereof on M, and one side upon the line M L, and by the other side draw a line at length, as the line M O, crossing the line L K in O ; so shall O upon your Board represent the Place A in the Field : Again, Take your Rule, and go to D, and there resting it upon the Staff, look by one edg to A, and by the other

to B, and keeping it at that Angle, bring it to the Board, and lay one side upon the line M O, and by the other draw the line M P, crossing the line L N in the Point P, so shall P represent upon the Paper the second Place B in the Field, and being measured upon the same Scale whereof L M was measured, it will be found to be 250 foot, and that is the distance from A to B. And by this means you may find the distances of all the Places in the Figure, if you measure them upon the same Scale as L M, or O P were measured, and so shall you find

$$\text{The Distance } \left. \begin{array}{l} \text{LO} \\ \text{LP} \\ \text{MO} \\ \text{MP} \end{array} \right\} \text{ to Contain } \left. \begin{array}{l} 128 \\ 317 \\ 200 \\ 210 \end{array} \right\} \text{ Foot.}$$

P R O B L. VI.

How to take the Distance between One or more Places, by a Ten Foot Rod (divided into Inches) only.

F I G. XI, and XII.

Standing at A, I would know how far it is to the Tree at B, tho I cannot come near it.

Standing at A, I measure in a right line from thence 30 foot, from A to *a*: And looking towards D, I measure out 30 foot more, as from A to C; and measuring the distance *a* C, I find it to be 25 foot, which laid down upon Paper, do make the Triangle A C *a*, of which draw the line A *a* out at length.

Then standing at C, I measure in a right line towards B, 25 foot, from C to *b*, and the distance between *a* and *b*, I measure to be 20 foot, which makes the Triangle C *a* *b*, Draw the side C *b* at length, till it cross the former line A *a*, extended in B; so shall the line A B (being measured by the same Scale that the other Lines were laid down by) be found to contain 82 foot, and such is the distance between A and B.

And according to this Method may the distances from several Places be measured, As in Figure XI. Where standing at G and H, you may find the distance between E and F; and also all the other intermediate distances, as from G or H, to E or F, as also the distances G E, G F, H E, H F, &c. as by Figure XII. is evident.

S E C T. III.

Of Planometria: Or Land-Measuring Mechanically.

FOR the Measuring of Land (by a Chain only without any other Graduated Instrument, which I call) Mechanically: The best Chain that I can advise you to, is one that is commonly known by the name of *Gunter's Chain*, and it contains in length four *Rods*, *Poles*, or *Perches* (which are all one), and each Pole contains 16 foot and a half: So that this Chain is 66 foot in length, and is divided into 100 equal Parts or *Links*, which are distinguished by having a *Brass Ring* at every Ten Links end: And one of these *Chains* in *Breadth*, and Ten of them in *Length*, do make One just *Acre* of Land according to the Statute: And thus

thus much concerning the *Chain* it self. — And now, before I come to shew you how to take the Plot of a Field by help thereof, without any other Graduated Instrument, I think it convenient, first to shew you how any Piece of Land measured by such a Chain may be cast up; that is, to know how many *Acres, Roods, and Perches*, such a Piece of Ground so measured doth contain. And in order thereunto I shall begin with the Mensuration of *Squares, Triangles, &c.*

I. To Measure a Square Piece of Land.

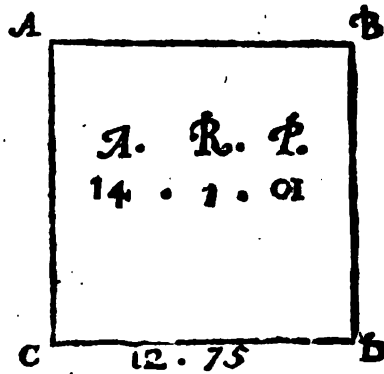

IF your Piece of Ground be exactly four Square, and have all the sides of equal length, and at right (or square) Angles, as the figure *ABCD*; and by your Chain you find that each side thereof contains 12 Chains, and 25 Links; you have no more to do, but multiply 12 C. 25 L. by 12 C. 25 L. as you see done in the Margent. And the Product is 1425625, from which (always) cut off five Figures towards the Right hand, by a Point or Line, and then the Product will be 14.25625; that is 14 Acres, and .25625 hundred thousand parts of an Acre; and to know how many *Roods and Perches* that is, multiply .25625 by 4, (because there are 4 *Roods* in one *Acre*) and the Product will be 1.02500; and five figures cut off, there is 1 beyond the Prick, which is 1 *Rood*, and .02500 remaining, which multiply by 40, (because there are 40 *Perches* in a *Rood*) and the Product will be 1.00000; from which five figures being cut off, there will remain 1. which is one *Perch*: So that this Square Piece of Land thus measured, will contain 14 *Acres*, 1 *Rood*, and 1 *Perch*.

12.75
12.75

6375
8925
2550
1275

A 14.25625
.25625
4

R 1.02500
.02500
40

P 1.00000

II. To measure a Square Piece of Land, whose Length and Breadth are unequal.

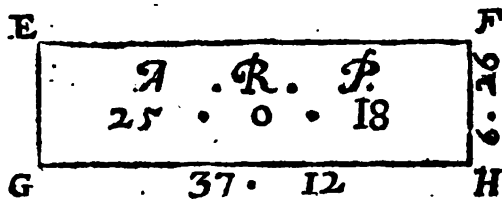

LET CDEF be a Furlong in common Field, or the like; and let the length thereof GH be 37 Chains and 12 Links, and the breadth thereof

RECREATIONS

$$\begin{array}{r} 27.12 \\ 9.26 \\ \hline 16272 \\ 5424 \\ \hline 24408 \\ \hline \end{array}$$
 A. 25.11312
 4

 R. 0.45248
 40

 P. 18.09920

thereof FH 9 Ch. 26 L. Multiply 27. 12. by 9. 26; and the Product will be, five figures being cut off 25. 11312, which is 25 Acres; and the remainder 11312 multiplied by 4, the Product (five figures being cut off), is 0. 45248, which is 0 Roods: And the remainder 45248 multiplied by 40, and five Figures cut off, will be 18. 09920, which is 18 Perches; so that this Piece of Land contains 25 Acres, 0 Roods, 18 Perches. As is seen in the Margent.

III. To measure a Triangular Piece of Land.

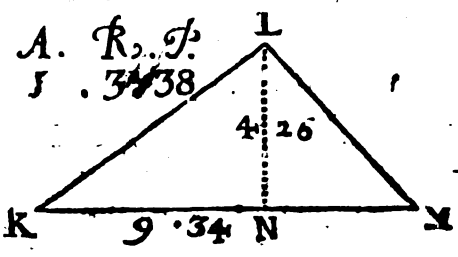

$$\begin{array}{r} 4.67 \\ 4.26 \\ \hline 2802 \\ 934 \\ \hline 1868 \\ \hline \end{array}$$
 A. 1.98942
 4

 R. 3.95768
 40

 P. 38.30720

TO measure Triangular Pieces of Land, you must multiply Half the length of the *Base* by the *Perpendicular*, and that Product shall give the Content of the Piece. So in the *Triangular Piece* of Land KLM, the length of the line KM is 9 Ch. 34 L. the half thereof is 4 Ch. 67 L. this multiplied by 4 Ch. 26 L. the length of the Perpendicular LN, the Product (five figures being cut off) is 1 Acre, and .98942 remaining; which multiplied by 4, the Product is 3 Roods, and .95768 remaining; which multiplied by 40, it produceth 38 Perches, &c. as in the Margent: So that this Triangular Piece of Land contains 1 Acre, 3 Roods, and 38 Perches; which is 2 Acres wanting only 2 Perches.

IV. How to measure an irregular Piece of Ground, of Four unequal Sides.

Suppose the figure OPQR to be such a Piece of Land to be measured by the Chain only.

First

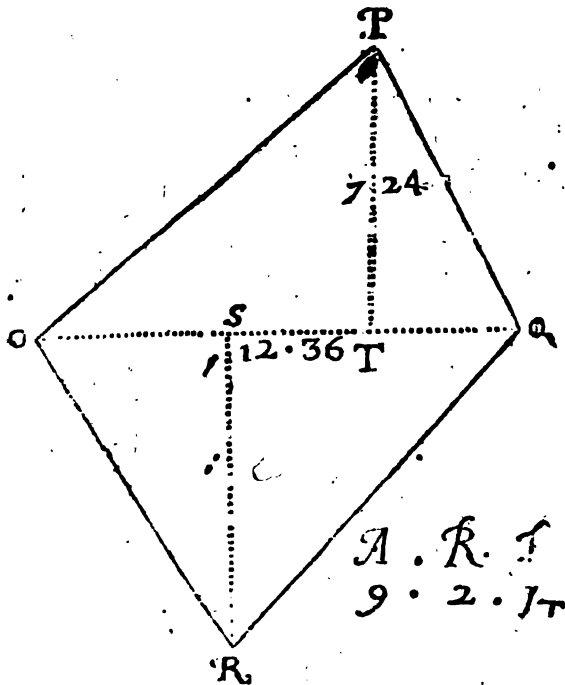

First, measure the Length or Diagonal thereof O Q, finding it to contain 12 Chains, 36 Links, which set down; then measure the Perpendiculars P T and R S, finding one to be 7 C. 24 L. the other 8 C. 28 L. which added together makes 15 C. 52 L. the half whereof is 7 C. 76 L. which multiplied by the length O Q, 12 C. 36 L. the Product is 9 Acres, and .59136, which multiplied by 4, the Product is 2 Roods, and .36544 remaining; and that multiplied by 40, produceth 14 Perches, &c. as in the Margent; and the whole Content of the Triangle is 9 Acres, 2 Roods, and 14 Perches.

12.36
7.76

7416
8652
8652

A. 9. 59136
4

R. 2. 36544
40

P. 14. 61760

V. Of Irregular Pieces of Ground of many Sides, how to reduce them into Triangles, and to measure them.

LET ABCDEFGH be a Field to be measured: In regard that the Field is irregular, it must therefore be first reduced into Triangles by drawing (or imagining) lines to be drawn from one Angle to another, as the lines A D, D B, A E, and F H; by which lines so drawn (or imagined) the whole Figure will be reduced into Six Triangles, namely,

Into the Triangle {

B C D
A D B
A D E
A E F
A F H
F G H

These

R E C R E A T I O N S

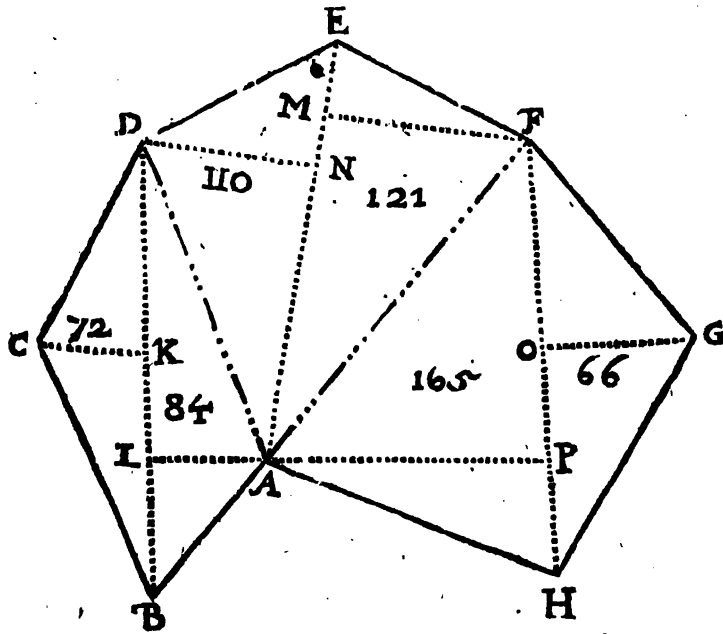

These six *Triangles* being measured severally, according to the directions before given, the Contents of all of them added together into one Sum, will give you the Content of the whole *Piece* in Acres, Roods, and Perches.

		A. R. P.
Suppose the Triangle	B C D	1 1 16
	A D B	1 2 12
	A D E	2 0 10
	A B F	2 1 03
	A F H	3 0 15
	F G H	1 0 38
The Sum		11 2 14

Which is the Content of the whole Field.

But for an Abbreviation of this Work, you need not to find the Content of every single *Triangle*, but of every *Trapezia* or *Four-sided Figure*, as is taught in the Fourth *Problem* next before going; for the *Figure* is as well divided into *Trapezias* as into *Triangles*, namely, into the Three *Trapezias* ABCD, ADEF, and AFGH; and so by this means you will abbreviate half your work; for if you measure the Three *Trapezias* severally, you shall find

		A. R. P.
The <i>Trapezia</i>	A B C D	2 3 28
	A D E F	4 1 13
	A F G H	4 1 13
The Sum		11 2 14

Note, That of what *Number* of *Sides* your *Figure* consists of, the *Number* of *Triangles* into which it will be reduced, will (always) be less by *Two* than the *Number* of *Sides*: As in this *Figure*; the *Number* of *Sides* are *Eight*, and the *Triangles* are but *Six*; two less.
And

And thus have I done with the *Chain*, as to the description of it; and how to cast up any *Figure* or *Piece of Land*, *Regular* or *Irregular*, measured thereby, in *Acres*, *Roods*, and *Perches*: It resteth now, that I shew you how to make use of it in the *Field*, in measuring of any *Irregular Piece of Ground*; and that shall be the *Work* of this next *Paragraph*.

VI. *How to take the true Plot of any Irregular Field of many Sides and Angles, by the forementioned Chain only, without any Graduated Mathematical Instrument; and to make a Plot of the same upon Paper or Velum.*

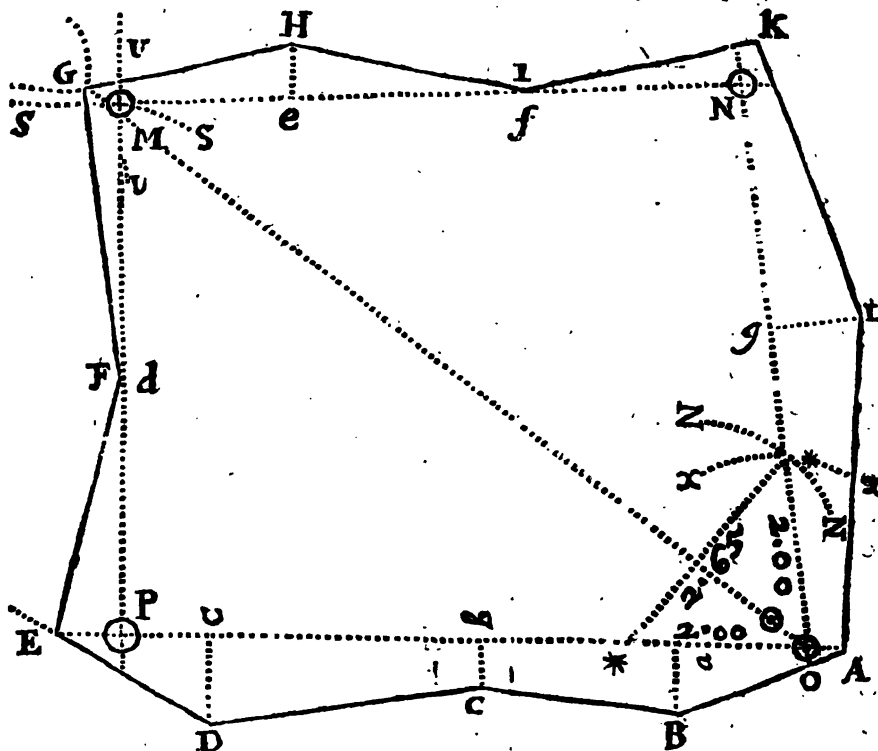

LET ABCDEFGHIKL, be an Irregular *Field* to be measured as aforesaid.

When you first enter the *Field*, cause *Beacons* or other *Visible Marks* to be set up near the principal *Angles* or *Corners* of the *Field*, as those at M, N, O, and P.

Secondly, Consider the best corner to begin at (tho any will serve) as I make choice of that Mark at O.

Thirdly, Take out your *Chain*, and holding one end at the *Beacon* at O, measure out 2 *Chains* (or more or less, as you see occasion) from the *Beacon* at O towards the *Beacon* at N, and at the end of the 2 *Chains* set up a small *Bow* or *Stick* at *. — Then again, from your *Beacon* at O measure 2 *Chains* more in a right line towards P, and there set up another small *Bow* or *Mark* as at *. — And then measure with your *Chain* the distance between your two *Marks* * and *, which here is 2 *Chains* 65 *Links*.

Fourthly, Prepare a *Book*, or *Sheet of Paper*, *Ruled* as in the *Margin*, to set down your *Measures* as you go along, but first at the top of it make a *Triangle* answerable to that which you measured out in the *Field*, and set such *Numbers* to it as you there measured, as 2 *Chains* from O to * both ways, and 2 *Chains* 65 *Links* from * to *.

R E C R E A T I O N S

This done, go into the Field to your Beacon at O, and measure the distance of it from the hedge on your left hand, finding it to be 20 Links of your Chain, which set down on the left hand Column of your Book, against 0 Ch. 00 L. because the Hedge was on your left hand.

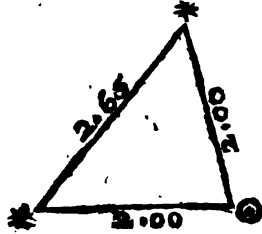

Sets off	Ch.	L.	Sets off
o 20	o	00	
o 70	1	40	
o 50	3	40	
o 90	6	50	
o 40	7	20	
<hr/>			
e 70	o	00	
touch	2	70	
o 30	5	50	
<hr/>			
o 25	9	00	
o 60	1	80	
o 15	4	25	
o 40	6	50	
<hr/>			
o 30	o	00	
o 95	2	70	
o 40	5	90	

Then with your Chain measure from the Beacon at O, towards that at P, in a right line, and as you go along, at the end of 1 C. 40 L. you find a Break or Bend in the Hedge, distant from your Chain 70 L. Set the 1 C. 40 Links in the middle Column, and the 70 L. by it; then going on farther, at the end of 3 C. 40 L. you come against another Break or Bow in the Hedge, distant from your Chain-Line 50 Links, both which set down in your Book: And going on farther towards P, at the end of 6 C. 50 Links, I find another Break or Bow distant from my Chain-Line 90 Links, both which set down, and measure on to your Beacon at P, which will terminate at 7 C. and 20 L. which set down, and because the Beacon at P is 40 Links distant from the Hedge, set 40 Links by the 7 C. 20 L. and draw a Line cross your Book, to signify that you have done with that side of the Field.

Then in your Book under Ch. L. write 0 00; and because your Beacon at P is distant from the Hedge G H 70 L. set that down against 0 00, and go on and measure towards the Beacon at M, and when you have measured 2 C. 70 L. you come to *touch* the Bow in the Hedge at F, wherefore set down 2 C. 70 L. and against it write *Touch*. Then measuring on to your Beacon at M, you find the length to be 5 Ch. 50 L. which set down, and by it 30 L. which is the distance of the Beacon M from the Hedge. Thus having finished this side of the Field, draw a Line cross your Book, as before.

And in this manner must you deal with the other two sides, M N and N O, till you come where you first began. And this way for measuring of any irregular piece of Ground, is as exact as is possible to be performed by the best Graduated Instrument that can be made.

And

And thus having shewed you how to measure in the Field, and take account thereof in your Book, it resteth now to shew you how to lay the Plot or Figure of this Field down upon Paper or Velum, in order to the finding of the Content or Quantity of it in Acres, Roods, and Perches.

VII. *How to lay down upon Paper or Parchment any Piece of Ground taken by the Chain as before, in order to finding the Content or Quantity thereof.*

FOR the performance of this Work, you must provide for your use a Pair of very fine-pointed *Compasses*, and also a Ruler with several Scales of Equal Parts, such as is mentioned in the next Chapter, with a figure thereof. This Plot here described, is laid down by a Scale, that half an Inch is equal in length to one whole Chain of Four Pole; and the half Inch in the Scale is divided by *Diagonals* into 100 parts, answerable to the 100 Links into which your Chain is divided. Being thus provided of Scales and *Compasses*, you may begin your Plot in this manner.

1. Upon a sheet of Paper draw a right line at pleasure, as the line P O; towards one end thereof, as at the Station or Beacon by O, make a Mark, as \odot .

2. With your *Compasses*, out of your Scale take 2 Chains, (which in this Plot is one Inch) and setting one foot of the *Compasses* in \odot , the other will reach to the Point *, upon the line O P, and one foot of the *Compasses* still resting in the point \odot , with the other describe the obscure Arch x x. Then take out of your Scale 2 Ch. 65 L. (which was the distance you measured from * to *) and setting one foot of that distance upon the Point *, in the Line O P, with the other describe another obscure Arch z z, crossing the former in the Point *, which is upon the line O N; and through the Point * draw another right line $\odot * N$ at length.

3. These two Lines being drawn, repair to your *Note-Book*; and therein finding your Chain-Line O P to be 7 Chains 20 Links, take 7 C 20 L. from your Scale, and set them from \odot to P. Also finding by your Book, that the Chain-Line O N did contain 5 C. 90 L. take that also out of your Scale, and set it upon the Line from O to N; then the Chain-Line P M being 5 C. 50 L. take them out of your Scale, and setting one foot of the *Compasses* in P, with the other describe an obscure Arch s s; and the Chain-Line M N being 6 C. 50 L. take them out of your Scale also, and setting one foot of the *Compasses* in N, with the other foot describe the obscure Arch v v, crossing the former in the station point \odot by M, through which Point draw the right lines P M and N M at length: And thus have you drawn upon Paper the Quadrilateral Figure M N O P, of the same Length and with the same Angles as you measured them with your Chain in the Field.

4. Having gone thus far, lay your *Note-Book* before you; and seeing that at your beginning at \odot , your Beacon at \odot did stand 20 L. distant from the Hedge, take 20 L. out of your Scale, and set them from \odot to o; also at 1 C. 40 L. at a, the bow of the Hedge was distant from the Chain-Line 70 L. take first 1 C. 40 L. and set them from O to a, and the 70 L. from a to B, and draw the line A B; Then take 3 C. 40 L. and set them from O to b, and 50 L. from b to C, and draw the line B C. Then take 6 C. 50 L. and set them from O to c, and 90 L. from c to D, and draw the line C D. Then at 7 C. 20 L. which is at the

Beacon P, set 40 Links to the Hedge, and through that Point draw the Line D E: So is this side of your Field finished.

5. Begin again at the Beacon by P, where you find by your Book, that the Beacon was distant from the Hedge 70 L. set 70 L. from \odot to E. Then at 2 C. 70 L. you find that your Chain-Line did touch the Hedge; wherefore take 2 C. 70 L. from your Scale, and set them from P to F (or d) and draw the line E F; then your next length 5 C. 50 L. will reach from P to M, where the Beacon was 30 L. from the Hedge, set 30 L. from \odot to the Hedge, and through that point draw the line F G. And thus have you finished your second side: And in the same manner you must deal with the other two sides; and in so doing you shall have compleated your Work, and have the exact Draught of your Field upon a sheet of Paper, which you may cast up into Acres, Roods, and Perches, by the Directions given in the preceding Third Paragraph.

And if you measure the small Triangles, and other four-sided Figures which are without the Chain-Lines, by themselves, and afterwards the Quadrilateral Figure M N O P, by it self, (which is the better way) you will find this Field to contain 4 Acres, 2 Roods, and 35 Perches.

C H A P. V.

Wherein is shewed how to take all manner of Heights and Distances; and to measure all manner of Land, of what kind soever, Instrumentally.

IN the foregoing Chapter you are taught how to take Heights and Distances, and also to measure Land Mechanically, whereby any person may very well (with more labour) perform many Geometrical Conclusions by slight and common Tools used by Mechanick Artificers; as by Squares, Joynt-Rules, Rods, &c. But in this Chapter I shall shew more Artificially how to perform the forementioned by Graduated Instruments: And altho I have handled this Subject at large in my Compleat Surveyor, yet I will here give a sufficient and exact way to do the like by an Instrument both portable and exact, not there mentioned; namely, a Semicircle, with its Appurtenances.

A. Description of the Semicircle.

A Semicircle in Geometry is thus defined, *A Semicircle is the one half of a Circle cut off by the Diameter, and is contained under a right Line, which is the Diameter; and an Arch or crooked Line, which is called sometimes the Circumference, Periphery, or Limb.*

The Semicircle which we here intend to describe and shew the use of, is usually made in Brass, the Diameter whereof may contain in length about 10 Inches, the Semidiameter half as much; the Diameter and Limb are either of them about an Inch in breadth: The Limb of this Semicircle is divided into 180 equal parts, called Degrees, and every of those Degrees is usually divided into smaller equal parts, according to the bigness of the Instrument, (usually into four) so is every small division or part, 15 Minutes. It is sometimes divided by Diagonals, so that you may (the
the



the Instrument be small) take off every third or fourth Minute. These Degrees are numbred from the left hand towards the right, by 10, 20, 30 &c. to 180; and back again from the right hand towards the left, by 190, 200, 210, &c. to 360.

Upon the Centre of this Semicircle is placed a round Box of Brass, in the bottom whereof is a *Chard*, having upon it the 32 points of the Mariners Compass, and over it a *Needle* covered with Glass; this *Needle* is at any time to set the *Diameter* of the Semicircle due North and South, or according to any other Coast.

Between the Semicircle and this Box is an *Index*, which moves upon the Centre of the Semicircle, and is of sufficient length to cut at either end thereof the Degrees on the Limb of the Semicircle. It hath upon it two *Sights*, through which you may look either backward or forward, to any Mark or Object.

On the backside of the Semicircle is screwed a *socket*, into which goes another *socket* called a *Ball-socket*; which serveth to set the Semicircle when it is upon the *Staff* in any position whatsoever, as *horizontal*, or *level*, *vertical* or *perpendicular*, or *reclining*, or *inclining* to any Angle.

Into this *Ball-socket* there goes the head of a *three-legged staff*, which supporteth the Instrument in the field.

These are all the parts of the Semicircle, as it is to be used in the fields to make observations; but to lay down your Work at home, there belongeth,

1. A *Protractor*.
2. A *Scale*.
3. A *Pair of Compasses*.
4. A *protracting Pin*.

1. The *Protractor* is made of a thin piece of Brass divided in all respects as the Semicircle was, and numbred in the same manner from 1 to 180 degrees, but from 180 degrees to 360 degrees; it ought to be numbred from the left hand towards the right, contrary to the numbering of your Semicircle. The use of this *Protractor* is to lay down the quantities of those Angles upon *Velum* or *Paper*, which you observe in the field.

2. Your *Scale* is a Ruler of Brass, upon which you may have what Scales you please, either *plain* or *diagonal*, as of 10, 11, 12, 16, 20, 24, 30 and 32 in an Inch; these Scales are to lay down the lengths of your Lines, as you measured them in the field with your Chain; and according to the largeness or smallness of your Scale, you may make your Plat or Draught of what bigness you please.

3. Your *Compasses* are to take your distances from your Scale, and to apply them to your Paper or Velum.

4. Your *Protracting Pin* is to fix in your Center Point, and also to mark the degrees on the edge of your *Protractor*.

The *Chain* which you measure your lengths in the field, may be of what length, and how you will divided; but the Chain which the Examples in this Book are wrought by, is 4 Pole in 100 Links.

The Use of the Semicircle, in taking of Heights, Depths, and Distances.

P R O P. I.

How to take the Height of any Tree, Tower, Steeple, or other Object, which standeth upright, and being accessible at one Station.

F I G. I.

LET *AB* be a *Castle-Wall*, whose height you would know; you standing at *C*, place your Semicircle at *G*, and turning it about by help of your Ball-socket, direct it to the Object; then fixing all your Sockets fast, by help of the screws for that purpose; hang a Thrid and Plummert upon the Center of your Semicircle, and move the Semicircle up and down till the Thrid and Plummert hang directly upon 90 deg. then laying the Index just upon the Diameter, there hold it, and looking through the Sights, mark what part of the *Castle-Wall* you see, for that part is in the true level with your eye, which point let be *D*; then, the Index still remaining fixed, move the Semicircle upwards or downwards; till (through the sights) you see the very top of the *Castle-Wall* at *A*, (the Semicircle still remaining immoveable) look what number of degrees and parts the Thrid cutteth, which degrees let be 55, which you must set down; lastly, measure the distance from *G* to *B*, which let be 200 Foot, to which add 5 Foot, the height of your Semicircle's Center from the ground *CE*, and it makes 205 Foot; by help of this distance, and the degrees before noted down, you may find the altitude of the *Castle-Wall*, as followeth.

Example.

Upon a piece of Velum or Paper, draw a line at length, as *MN*; towards one end whereof, as at *B*, erect a Perpendicular *AB*, representing the *Castle-Wall*; then from one of your Scales take with your Compasses 205 Foot; and set that distance upon your Paper or Velum, from *B*, the foot or bottom of the *Castle-Wall*, to *C*, so shall *C* upon your Paper represent the place on the ground where the Semicircle stood, and 5 Foot more being added (which is the height of your Semicircle from the ground) *BC* maketh 205 Foot, which taken from your Scale will reach from *B* to *F*.

This done, place the Center of your Protractor upon the Point *F*, and the Diameter thereof upon the line *MN*, then count 35 degrees (which is so much as 55 deg. which the thrid cut, wants of 90 deg.) upon the edge of the Protractor, and against it make a mark or point with your protracting Pen, through which point (or mark) and the point *F*, draw the line *FA*, cutting the line *AB*, representing the *Castle-Wall* in *A*; so shall *AB* be the height of the Wall, which being measured by the same Scale as *BF* 205 foot was taken from, will be found to be 143 foot; and so high is the *Castle-Wall* from the ground.

P R O P.

P R O P. II.

How to take the Height of an Object, which is not accessible at two Stations; by help of the Semicircle.

SUPPOSE A B to be a Castle-Wall as before, and you cannot come nearer to the Wall than G, for that there is a Moat about the Wall so broad.

First, Place your Semicircle at G, the edge of the Moat or Trench, and directing the sights to A, the top of the Wall, you shall find the Thrid to cut 30 deg.

Secondly, Go backwards a competent distance of ground, in a right line, as to F, and there placing your Semicircle as before, direct the sights to A, where you shall find the Thrid to cut 55 deg.

Thirdly, Measure the distance between G and F, which let be 125 Foot; these two Observations being made at G and F, and the distance between them measured by the Chain, the altitude of the Wall may be easily attained in manner following.

Example.

First, Upon Paper, or the like, draw a line M N, upon which, towards one end thereof, as at F, place the Center of your Protractor; and because the Thrid there cut 55 deg. make a mark against 35 deg. of your Protractor (which is so much as 55 deg. wants of 90 deg.) and through this point, and the point F, draw a right line at length upwards.

Secondly, For that the distance between G and F (your two Stations) was 125 Foot, take 125 out of some one of your scales, and set off that distance upon your paper from F to G.

Thirdly, Lay the Centre of your Protractor upon G, and the Diameter thereof upon the line M N; and because when you made Observation at G, the Thrid cut 30 deg. make a mark against 60 deg. of the Protractor, (which is so much as 30 deg. wants of 90 deg.) and through this mark, and the point G, draw a right line at length upwards, continuing it till it cut the former line drawn from F, which it will do in the point A.

Lastly, From the point A let fall a perpendicular upon the line M N, which will fall upon the point B, so is A B the height of the Castle-Wall, which if you take in your Compasses, and measure it upon the scale from whence you took your distance F G, you shall find it to contain 143 Foot, and so high is the Castle-Wall.

P R O P. III.

A Fort or Castle being besieged, how the Besiegers shall know of what length to make Scaling-Ladders that shall reach from the edge of the Moat or Trench to the top of the Wall.

LET A B be the Wall of a Fort or Castle, and that the Castle within were besieged, the Besiegers lying at F, and cannot come nearer to

to the Wall than G, the edge of the Moat; wherefore standing at G, make Observation with your Semicircle as you did before, and you shall find the Thrid to cut 30 deg. — Do the like at F, and you shall find the Thrid to cut 55 deg. and the distance between G and F measured will be found to be 125. — These two Observations being made, and the distance FG measured (all which are the same as in the last Prop.) you may protract or lay down the same upon Velum or Paper, in all respects as in the former Prop. and so measuring the line GA upon the same scale that GF was measured by, you shall find it to contain 166 Foot, and so long must Ladders be to scale the Walls of this Fort or Castle.

P R O P. IV.

Standing upon a Wall or Tower of a known height, to find how far any Ship, Tree, &c. is from you.

LET A be the top of a Tower or Castle standing by the Sea-side, and let F be a Ship lying at Anchor, and you would know how far that Ship is off the Castle-Wall.

Standing upon the Tower-Wall at A, with your *Semicircle*, direct the sights (the Index lying upon the Diameter) to F, the Thrid will cut 55 deg. Then, the Castle-Wall being 143 Foot high, by help of these two you may find the distance that the Ship at F is from the Castle-Wall B, in this manner:

Upon Paper or Parchment draw a line AB, representing the Castle-Wall, and upon it by help of your scale, set the height thereof 143 Foot, from A to B, and upon the point B erect the Perpendicular BF.

Then placing the Center of your Protractor upon A, turn it about upon that Point, till 55 deg. (which were the degrees cut by the Thrid) come to lye directly upon the line AB, then at 00 deg. (or the beginning of the Semicircle of the Protractor) make a mark close by the edge thereof, through which point and the point A, draw a line at length downwards, which line being drawn, will cut the line BF in the point F, so the distance BF being taken in your Compasses, and measured upon the same scale from whence AB (the height of the Wall) was taken, it will be found to contain 205 Foot, and so far is the Ship F from the Castle-Wall B.

P R O P. V.

How to take an inaccessible Distance at two Stations by the Semicircle.

F I G. II.

SUPPOSE you were standing at G, and that it were required of you to know how far distant the Tree of A is from you, between which and you there is the River D, so that you cannot come near A.

First, Place your *Semicircle* at C, laying the Index on the Diameter thereof, and turn the Semicircle about till through the sights you see the Tree at A, and there fixing the Semicircle, turn the Index about till you see the Mark set up at B, and there note what degrees the Index cutteth, which let be 110 deg. Secondly,

Secondly, Remove your Semicircle from C to B (setting up a Mark at G, where your Semicircle before stood) and laying the Index on the Diameter thereof, turn the Semicircle about till through the sights thereof you see the Mark at C, where your Instrument before stood, and there fixing the Semicircle turn the Index about till by the sights you see the Tree at A, and there also note what degrees the Index cutteth, which let be 40 deg.

Thirdly, Measure the distance between C and B, which let be 120 Foot; by help of these three you shall find the distance of A from either C or B, as followeth.

Example.

Draw a line upon Paper, as A C, and laying the Centre of your Protractor upon C, and the Diameter thereof upon the line C A, with your protracting Pin make a mark against 110 deg. and through that point and the point C, draw a line C B; then from your Scale take 120 Foot, and set it upon the line C B, from C to B.

This done, lay the Center of your Protractor upon the point B, and the Diameter thereof upon the line C B, and make a mark against 40 deg. through which mark and the point B, draw the line B A, cutting the former line C A in the point A.

Lastly, If you take in your Compasses the line C A, and measure it upon the Scale from which you took B C 120 Foot, you will find it to contain 154 Foot and about half a Foot, and such is the distance A C.

In like manner, if you measure A B by the same Scale, you shall find it to contain 224 Foot, and about half a Foot.

P R O P. VI.

How to measure the Distance of several Places from you, as also of one from another, by measuring only of one Distance, and observing of Angles by the Semicircle.

F I G. III.

LET A, B, C, D, E, be several places, as Churches, in a Town or City, or the like, whose distance you require one from another.

First, Make choice of two places, from either of which you may see all the places, whose distance you require, which places let be F and G, distant one from another 100 Foot.

Secondly, Place your Semicircle at F, and laying the Index on the Diameter, turn the Semicircle about till through the sight you see your other place of standing at G; and there fixing your Instrument, first direct your sights to A, noting what degrees the Index cutteth; then to B, and note what degrees are there cut by the Index, doing the like at C, D, and E; all which degrees note down in a Book or Paper.

Then removing your Semicircle to G, and setting up a Mark at F, lay the Index on the Diameter thereof, and turn the Semicircle about till you see the place of your former standing at F, and there fixing the Semicircle, make observation of every place, as you did at F: First, directing the sights to A, noting the degrees cut by the Index, likewise to B, C, D, and E.

H

By

By these observations of Angles, made at either station F and G, and and the stationary distance, you may draw a perfect draught of all the places upon Paper or Velem, in their true position and scituation, in manner following :

Example.

First, Upon your Velem or Paper draw a line F G, containing 100 Foot of any Scale, which line shall represent the distance of your two stations.

Secondly, Place the Center of your Protractor upon F, and lay the Diameter thereof upon the line F G, and there keeping it steady, make a mark against those deg. which the Index cut upon the *semicircle* when the sights were directed to A ; also make a mark against those deg. of the Protractor which the Index cut at B, and the like at C, D, and E.

Thirdly, Through the point F, and every one of those marks you made against the side of the Protractor, draw lines, as F A, F B, F C, above the line F G, and F D, F E, below the line.

Fourthly, Lay the Center of your Protractor upon the point G, and the Diameter thereof upon the line F G, and there keeping it fast make marks against the edge thereof, at those degrees the Index cut upon the Semicircle, when the sights were directed to A, B, C, D, and E ; and through those points and the point G, draw right lines G A, G B, G C, G D, and G E, cutting the former lines drawn from F, in the points A, B, C, D, and E ; which points will stand in the same position and scituation as the Churches or other places in the City or Town do ; and if you take in your Compasses the distance between any two of them, and measure that distance upon the same Scale that F G 100 was measured from, it will there shew you the distance of those two places.

The Use of the Semicircle in Measuring of Land.

P R O P. I.

To take the Plat of a Field by placing the Semicircle in any part thereof, from whence all the Angles of the Field may be seen.

PLace your Semicircle upon its staff in some convenient place of the Field (whose Plat you would take) that from thence you may conveniently see all the Angles thereof, then setting the Semicircle level (by help of the Ball-socket) lay the Index upon the Diameter, and turn the Semicircle about till the Needle hang directly over the North and South Points of the Chard, and there fix the Semicircle, by help of the screw of the *plain Socket*, then doth the Instrument (the Diameter thereof) lye directly in the Meridian, and is fitted for your present use.

Your Instrument thus fixed, cause marks to be set up at every angle of the field (or rather let one go from angle to angle with a long staff having a white cloth or paper tied to the top thereof) and coming to your Instrument, the Diameter being next to you, and the Limb of the Semicircle from you, turn the Index about till through the sights thereof you espy the first of your marks (or man) which is on your right
and,

hand, and when you have directly found your mark, let the Index rest, and see what degrees and parts of a degree of the Semicircle are cut thereby; which degrees and parts note dōtē down in a book or paper ruled as that which followeth.

In this nature must you deal with every angle round about the field, beginning at that which is next towards your left hand, and proceeding gradually from that towards the right hand, till you find that end of the Index which cut the degrees, falls off of the Instrument, (which will always be when you come past 180 degrees) then must you look through the other sights, and the Limb of the Semicircle will be next to you, and you must count your degrees from 180 towards 360; to which, before you come, you will have passed all your Angles.

When you have taken observation of all your Angles, you must, with your Chain, measure from the place where your Semicircle stands, to every Angle (beginning with the first, and so proceeding from the left towards the right hand) and note how many Chains and Links each line contains, which lengths must be set down in your book or paper, in a column by themselves against the degrees which the Index cut, when you made observation at that Angle, that is, the first length against the first degrees, and the second length against the second degrees; and in this order must you proceed till you have measured all your lengths.

The foregoing Precepts illustrated by Example.

F I G. IV.

LET *a, b, c, d, e, f, g,* be a field to be Surveyed. Place your Semicircle (it being a convenient place) at O, the diameter thereof, as also the Needle in the Box, hanging over the North and South Points in the Chard, then will they lye directly over the line NS in this figure; then fix your Instrument, and directing your sights to A (your first Angle) you shall find the Index to cut 12 d 15 m. which set down in your book or paper; then directing your sights to B, the Index cuts 37 d. at C, 94 d. 30 m. and the rest, as in the following Table, representing your book or paper in which you took your notes.

		<i>d.</i>	<i>m.</i>			<i>C.</i>	<i>L.</i>
The Index cut when directed to the mark,	[A	— 12.	15]	And the distance from O the place of the Se- micircle, was	OA	— 10. 35
		B	— 37.	0]		OB	— 9. 45
		C	— 94.	30]		OC	— 10. 30
		D	— 169.	15]		OD	— 6. 20
		E	— 193.	0]		OE	— 8. 93
		F	— 270.	30]		OF	— 8. 09
		G	— 347.	0]		OG	— 5. 20

Having gone through all your Angles, and noted them down in your book or paper, as is done in the foregoing Table, in the column having *d. m.* at the top thereof (signifying Degrees and Minutes) you must then go to the measuring of your lines, where you shall find OA to contain 10 Chains 35 Links, OB 9 Chains 45 Links, and the rest as in the Table in that column which hath C. L. at the top thereof, C signifying Chains, and L Links.

When you have thus taken observation of all your Lines and Angles, and noted them down in a Book or Paper, you may at pleasure draw the Plat of the Field upon Velum or Paper, by the Precepts which shall be delivered in the following Proposition.

P R O P. II.

How to lay down the Plat of the former Field upon Velum or Paper, by help of the former Observations of Lines and Angles.

UPon a piece of Velum or sheet of Paper, draw a line for the Meridian or North and South Line, represented by the line in the Figure by NS. In some convenient place of that line (as at O) assign a point, which point O upon your paper, represents or signifies the place in the field where your Semicircle stood when you made observation of your Angles.

Upon this point O place the Center of your Protractor, laying the Meridian Line or Diameter thereof just along the line NS, drawn upon the paper, and there hold it fast. Then having recourse to your Table of Angles, which you observed in the field, you find your first to be 12 deg. 15 min. wherefore, close to the edge of your Protractor, and against 12 deg. 15 min. make a mark with your protracting Pin; and still keeping your protractor in the same position unmoved, make a mark against 37 deg. your second Angle, also against 84 deg. 30 min. your third Angle, and against 169 deg. 15 min. your fourth Angle.

Then because your fifth Angle at E exceeds 180 deg. it being 193 deg. you must turn the *Semicircle* of your *Protractor* downwards, laying the Center thereof upon the point O, and the Diameter upon the line NS as before, and against 193 deg. make a mark with your protracting Pin, do the like against 270 deg. 30 min. your sixth Angle, and against 347 deg. your last Angle.

These points being marked upon your Paper, through every one of them, and the point O, draw obscure lines, as O A, O B, O C, O D, O E, O F, and O G. — Then having recourse to your Table of Lines which you measured in the field, you find that the first line O A, contained 10 Chains 35 Links, wherefore from some Scale (according to the bigness you would have your *Plat*) take 10 C. 35 L. and set it upon your paper from O to A, this point A upon the paper shall represent the first Angle in the field A; your second length being 9 C. 45 L. take that from your Scale, and set it upon your paper from O to B. Do thus with all the rest of the lengths; and when you have found out and marked upon your paper the several points A, B, C, D, E, F, and G, if you draw lines from point to point, as from A to B, from B to C, from C to D, &c. you shall constitute the figure A B C D E F G, which shall be the exact *Plat* of your *Field* O. And thus may you take the *Plat* of any *Field*, where you may see all the Angles from any one place.

P R O P. III.

How to take the Plat of a Field or other piece of Ground, by placing the Semicircle in some one Angle thereof, from whence all the rest may be seen.

Your Semicircle being placed in the Angle where you intend to make your observation with the Index upon the Diameter thereof, and the Needle hanging over the Meridian Line in the Chard. It being thus fixed, direct your sights to the first Angle towards your left hand, noting the degrees and minutes cut by the Index, and note them down in a book or paper, in all respects as you did those in the former Proposition.

Then measure with your Chain from that Angle where your Semicircle standeth, to every one of the other Angles, noting the lengths of every of them, and write them also down in your book or paper, proceeding thus from the first line on your left hand, till you come round the field to that again.

Example.

F I G. V.

LET HKLMNOPQ be a piece of Ground to be measured in the manner here prescribed: The Semicircle placed in the Angle Q, direct the sights to H, where the Index cuts 15 deg. which note down, then direct the sights to K, where the Index cuts 31 deg. 30 m. likewise to L, M, N, O, P, where the Index cut the degrees and parts, as in the Table following:

	d.	m.		C. L.	
The Index cut when directed to the Angle,	H —	15. 0	And the distance from the Angle Q, as	QH —	9. 90
	K —	51. 30		QK —	10. 25
	L —	87. 14		QL —	11. 60
	M —	106. 0		QM —	12. 30
	N —	168. 15		QN —	12. 0
	O —	196. 0		QO —	10. 85
	P —	250. 0		QP —	6. 88

P R O P. IV.

By the former Observations of Lines and Angles, to draw the Plat or Figure of the Field upon Velum or Paper.

Draw upon Velum or Paper a line N S, representing the Meridian Line, upon which line assign a point as Q, which denotes the place where your Semicircle stood in the field.

Upon this point Q, lay the Center of your Protractor, and the Diameter thereof upon the line N S; and there holding it fast, look in your Table what degrees the Index cut when you made observation at H, which were 15 degrees, make a mark against 15 degrees of your Protractor; likewise see by your Table what degrees the Index cut when

when you made observation at K, which were 31 deg. 30 min. make a mark against 31 deg. 30 min. of your Protractor; and in like manner do with every Angle, as at L, 87 deg. 15 min. at M, 106 deg. 0 min. at N, 168 deg 15 min. at O, 196 deg and at P, 256 deg. at all which numbers of degrees, make marks against the side of your Protractor.

Then removing your Protractor, draw right lines from the point Q through every one of those marks, so shall you have upon your Velum or Paper the several Lines QH, QK, QL, QM, QN, QO, and QP.

Again repair to your former Table, where you shall find that the line QH, being measured by the Chain in the field, contained 9 Chains, 90 Links, take this distance from any of your Scales, and set it upon the line QH, from Q to H; and so have you the point H upon the paper.

In like manner, take 10 Chains 25 Links from your Scale, and set it from Q to K, so have you the point K upon paper. And in this manner deal with all the numbers of Chains and Links in your Table, and they will give you the points L, M, N, O, P, upon your Velum or Paper.

Lastly, If you draw the lines QH, QK, QL, QM, QN, QO, QP; you shall thereby constitute the true Symetry or Proportion of the field you measured, the several Angles whereof are H, K, L, M, N, O, P, and Q.

P R O P. V.

How you may by the Semicircle take the true Plat of any large piece of Ground, as Park, Wood, Marsh, or other spacious Inclosures, by going round about the same.

IN going round about a field (or other ground) to survey, there are two ways, but both effected by the same artifice; for in going about a field, you may either go about it on the inside of the field, or on the outside thereof; and sometimes you shall be constrained to go partly within and partly without; and if you go without the field, you may (if you will) take the quantity of the Angles within; and if you go on the inside, you may take the quantity of the Angles without. Of both which ways I shall give Examples.

I. *By going about the Field within the same.*

Let A B C D E F be a Field to be measured by going about the same on the outside.

F I G. VI.

First, Begin at any Angle thereof, as A, and there place your Semicircle, laying the Index upon the Diameter, and turning it about, direct the sights to B, there fix the Semicircle, and turn the Index about, till through the sights you see the Angle at F, and there note what deg. the Index curreth, which you will find to be 300, for the quantity of the exterior Angle F A B without the field, or 60 deg. for the quantity of the interior Angle within the field; but (as I said before) going with-

without the Field I make use of the exterior or outward Angles : Then measure the side FA, which you shall find to be 10 Chains 25 Links, and the side AB 7 Chains 50 Links, these distances with the quantity of the Angle note down in a Book or Paper, as you see in the following Table.

Secondly, Remove your Semicircle to B, and laying the Index upon the Diameter, turn the Instrument about, till through the sights you see the place where your Semicircle last stood at A, and then fixing it, turn the Index about, till by the sights you see the Angle C, and there note the *degrees* which the Index cutteth, which here are 145 *degrees*, and the distance BC measured is 7 Chains 10 Links ; note both the *degrees* and distance down as before.

Thirdly, Carry your Semicircle to C, and placing the Index on the Diameter, look back to B, and there fix the Instrument, then turn the Index about till you see the Angle at D, where the Index cutteth 270 *degrees*, and the distance CD is 5 Chains 85 Links.

Fourthly, Remove the Semicircle to D, and the Index on the Diameter, look back to C, then fix the Semicircle and turn the Index about, till by the sights you see the Angle at E, the Index cutting 263 *degrees*, and the measured distance DE being 7 Chains, note these down in your book or paper.

Fifthly, Place the Semicircle at E, and the Index lying on the Diameter, look back through the sights to D, then fixing the Instrument there, turn the Index about till by the sights you see the Angle F, the Index cutteth 220 *degrees*, and the measured distance EF being 10 Chains 70 Links, both which you must note down. And,

Sixthly, Carry the Semicircle to F, and the Index lying on the Diameter, look back to E, and then fix the Instrument, then turn the Index about till by the sights you see your first Angle at A, the Index then cutting 210 *degrees*; these being noted down will stand as in this Table.

	<i>d.</i>	<i>m.</i>	C.	L.	
Angles.	A — 300 —	0	10 —	25	Sides.
	B — 145 —	0	7 —	50	
	C — 270 —	0	7 —	10	
	D — 263 —	0	5 —	85	
	E — 220 —	0	7 —	00	
	F — 210 —	0	10 —	70	

These Observations of Sides and Angles being made in the Field, and noted down as in the foregoing Table, a Plat thereof may be drawn upon Velum or Paper by help of the following Directions.

P R O P. VI.

How to draw a true Plat of the Field before measured, by help of the Table of Sides and Angles.

UPON your Velum or Paper draw a Line AB, containing 7 Chains 50 Links of any Scale, and upon the end A place the Centre of the *Protractor*, laying the Diameter upon the line AB, then the exterior Angle A being 300 *degrees*, make a mark against 300, and through

through that point and the point A, draw a line downwards as A F, containing 10 Chains 25 Links.

Secondly, Place the Centre of the *Prosector* upon B, and the Diameter upon A B, and against 145 degrees (the Angle at B) make a mark, and through that mark and B draw the line B C, containing 7 Chains 10 Links.

Thirdly, Lay the Centre of the *Protractor* upon C, and the Diameter upon B C, and against 270 deg. make a mark, through which, and C, draw the line C D, containing 5 Chains 85 Links.

Fourthly, Lay the Centre of the *Protractor* upon D, and the Diameter upon C D, making a mark against 263 deg. through which, and the point D, draw the line D E, to contain 7 Chains.

Lastly, Lay the Centre of the *Protractor* upon E, and its Diameter upon D E, and against 220 deg. make a mark, through which, and the point E, draw a right line E F, which will cut your line A F in F; so have you upon you Velum or Paper, the true figure of your Field, A B C D E F.

In all the Work of these two last Propositions, we have wrought by the exterior or outward Angles: If any have a desire to work by the interior or inward Angles, it is but taking the exterior Angle from 360 degrees, and the interior Angle will remain. So the Angle at A being 300 degrees, that taken from 360 degrees, leaves 60 degrees for the interior Angle at A. So B being 145 degrees, that taken from 360, leaves 215 for the interior Angle.

H. *By going about the Wood or Park on the Outside thereof.*

TH E foregoing way, where the Hedges are straight, and not many, and the Ground clear of *Wood, Pools, Quags,* and such like, is sufficient to perform the Works there intended: But if the *Wood* be overgrown, so that you cannot see from Angle to Angle, nor measure along by the Hedge-side, then make use of the way hereafter prescribed.

F I G. VIII.

Let A B C D E F G H I K L M N O, be a *Wood* to be measured and *Plotted*, and it is so overgrown with *Wood* that ye cannot by any means come within the same to measure any *Sides*, or see to take any *Angles*; wherefore you must go on the outside thereof: And having made choice of a place, as at P, where to begin your *Survey*, here set up a visible mark, then standing at P, look along the *Wood's* side towards Q, where set up another visible Mark. And at Q, look towards R, where set up another visible Mark as at R: From which looking along the *Wood's* side (as near the side as you can) set up another Mark as S, from whence you may see your first Mark at P: and by this means you have encompassed the whole *Wood* within the Quadrilateral Figure P Q R S: And now to begin your *Instrumental* Work:

1. Set up your *Semicircle* at P, laying the Index upon the Diameter thereof, and turn the whole Instrument about, till through the Sights you

you see the *Mark* set up at Q, and then fix the Instrument, and turn the Index about till through the Sights you see the last Mark at S: where the Index will cut 89 deg. 00 m.

d.	m.	C. L.	From
89	00	C. L.	From
0	00	1 80	P to A
3	55	0 90	a B
4	60	touch	at C
8	50	1 40	c D
11	15	0 50	d E
12	70	0 80	e F
15	00	touch	at G
18	80	0 0	at Q
<hr/>			
87	30	C. L.	From
0	00	0 90	Q to G
3	00	touch	at H
6	35	0 60	h I
6	90	0 00	at R
<hr/>			
91	00	C. L.	From
0	60	0 40	k to I
2	75	touch	at K
5	45	0 65	m L
8	40	0 70	n M
11	90	touch	at N
14	90	1 20	P O
15	65	0 0	at S
<hr/>			
92	30	C. L.	From
0	00	0 0	at S
1	10	0 85	q to O
4	70	touch	at A
6	50	0 0	at P

Which set down in the first Column of a *Field-Book*, or Paper, ruled like this in the *Margin*: Then at the beginning of your Measure from P towards Q, you find that the corner of the Wood at A is distant from P, 1 Chain and 80 L set down 1 C. 80 L. in the next Column; and in the third Column say, from P to A: — Then measuring along the *Chain-Line* from P towards Q, I find that from Q to a is 3 C. 55 L. which I set down in the first Column; and because a is distant from the Angle of the Wood at B 90 L. I set down 0 C. 90 L. and in the third Column, from a to B— Then measuring on till I come to b, 4 Ch. 60 Li. I find the Chain to touch the very corner of the Wood at C. wherefore, I write down 4 C. 60 L. in the first Column; *Touch.* in the second Column, and at C, in the third Column: And in this manner I proceed in *Measuring* and *setting down* (as in the *Margin*) till I come to the second Mark at Q: Then

2. Set up your *Semicircle* at Q, the Index upon the Diameter hereof; and turn the Instrument about till through the Sights you see your first Mark at P, and then fasten it: Then turn the Index about to R, where you shall find it to cut 87 Deg. 30 m. which set down in the first Column of your Book: And measuring from Q towards R, you find that at 3 Chains end, the Chain touches the Corner of the Wood at H, wherefore, write down 3 Chains in the

first Column, *Touch* in the second Column, and at H in the third Column: Then measuring on towards R, till I come to b, 6 Ch. 35 L. I find that the Angle at b, is distant from I, 60 Links: wherefore, I set down 6 C. 35 L. in the first Column, 60 L. in the second, and, from b to I in the third Column: And lastly, 6 C. 90 L. at R.

3. In like manner set up your Instrument at R, and at S, measuring and setting down as before, and as you see done; And you shall find all the Sides and Angles to be such as they are noted to be in the figure of the *Field-book* in the *Margin*: From whence, by what hath been already said, and the sight of the *Figure* (which will give more light to the Work than a whole *Chapter* of Directions) you may draw a true *Plot* of the Wood upon Paper or Parchment.

And for the casting up of the *Content* thereof the directions formerly given, in *measuring* by the *Chain* only : And those which follow in the next *Proposition* will sufficiently inform you.

But, by way of *Advertisement*, In this *Example* where you went on the outside of the *Wood*, you must first find the *Content* of the whole *Quadrilateral Figure* P Q R S, and then of the several small *Triangles* and *Trapezias* made without the *Wood*, as the *Trapezia*, P a B r, and the rest : Which being deducted from the *Content* of the whole *Quadrilateral* P Q R S, will leave the *Content* of the whole *Wood* included therein.

P R O P. VII.

The Plat of a Field being laid upon Paper, and the Scale by which it was laid down known, to find how much the said Field containeth in Acres, Roods and Perches.

T Here are several ways to effect this ; but I shall here deliver only one, which shall be general, and that which by all (or most) Surveyors is practised.

Every irregular Plat or Figure, before the quantity or content of it can be found, must first be reduced into such Regular Figures, for the mensuration whereof there are certain Rules : The most meet and convenient Figures into which Irregular Plats may be reduced, are Triangles and Quadrilaterals, called Trapezias, which is done by drawing of lines from Angle to Angle cross the Plat. And here note, That of how many sides soever your Plat consisteth, into so many Triangles, wanting two, will the Plat be reduced, and no less, as the Figure VII. denotes, where the Plat consisteth of 7 Sides, and it is reduced into 5 Triangles.

The manner of reducing the Plat into Triangles.

F I G. VII.

L ET the Figure A B C D E F G be a *Plat* which contains seven sides ; to reduce which into Quadrilaterals and Triangles, do thus :

First, Draw the line B F, so is part of the *Plat* reduced into the Quadrilateral A B F G.

Secondly, Draw the line F D, so is another part of the *Plat* reduced into the Trapezia B C D F ; and the other part of the *Plat* is comprehended in the Triangle F D E.

Thus the whole *Plat* being reduced, contains two Trapezias, *viz.* K and L, and the Triangle M, in number five, (for every Trapezia contains two Triangles) which are less by two than the number of sides.

To cast up the Quantity or Content of the Plat.

First begin with the Triangle M, whose base, F B, is 13. 75. that is, 13 Chains 75 Links, and his Perpendicular E Q, 7 Chains 12 Links.

Now the Quantity, Area, or Content of every Triangle, is found, By multiplying the length of the base by half the length of the perpendicular.

So here the base 13. 75. and the perpendicular 7. 12. the half whereof is 3. 56. if you multiply 13. 75. by 3. 56. (as if they were whole Numbers, tho in reality the 75 and 56 are Fractions) the Product will be 4. 89 500, and that is the Quantity of the Triangle F D E.

13.75
3.56

8250
6875
4125

4.89500

Secondly, For the Trapezia or Quadrilateral L, in which Trapezia you may see that the line C F is a common base to the two Triangles B F C, and C D F, for the perpendiculars B P, and D O, of both Triangles, fall upon it.

Now the Quantity of any Trapezia is found, *By multiplying the common base (here F C) by half the Sum of the two Perpendiculars which fall upon it (here B P, and D O.)*

So in this Trapezia, the common base C F, is 14 C. 90 L. and the sum of the two Perpendiculars B P, and D O, is 13 Chains 80 Links, the half whereof is 6. 90. If you multiply 14. 90. by 6. 90. the Product will be 10. 28100.

14.90
6.90

134100
8940

10.28100

Thirdly, For the Trapezia K, multiply 12. 66. (the length of the base B G) by 4. 55. half the sum of the two perpendiculars A H and F R, the Product of that Multiplication will be 5. 76030, which is the Quantity, Area, or Content of the Trapezia K.

12.66
4.55

6330
6330
5064

5.76030

Thus have you the Content of the two Trapezias and the Triangle. Now,

To find the Quantity of the whole Field, in Acres, Roods, and Perches.

Add the Products of the several Multiplications together, the Sum of them is the whole Quantity. So

The { Triangle M } containing { 4. 89500
 Trapezia K } { 5. 76030
 Trapezia L } { 10. 28100

Their Sum is — 20. 93630

Which is 20 compleat or entire Acres, and $\frac{2160}{10000}$ parts of an Acre; and to know how much that is, multiply 93630 by 4 (because 4 Roods make an Acre) the Product is 3 compleat, and $\frac{74520}{10000}$ parts of a Rood; and to know how much that is, multiply 74520 by 40 (because 40 Perches are contained in one Rood) the Product will be 29.80800, which is 29 compleat Perches, and $\frac{8000}{10000}$ parts of a Perch, which is inconsiderable, for 160 whole Perches make but one Acre.

$$\begin{array}{r} 93630 \\ \underline{\quad\quad 4} \\ 374520 \\ \underline{\quad\quad 74520} \\ \quad\quad 40 \\ \underline{\quad\quad\quad 29.80800} \end{array}$$

Thus have you the Area, Quantity, or Content of this Field cast up, and you find it to contain 20 Acres, 3 Roods, and 29 Perches. And in this manner may you cast up the quantity of any Irregular Plat whatsoever, remembering that in all your Multiplications you cut off 5 figures towards your right hand with a prick of your Pen, as in this Work I have done all along.

S.

great

ie Sole

Exam-
lift up
Pounds
: there

Effect
: Pro-
on by
of *two*
: same
: 100
ounds
o the
to the

Force
to be

one
tem ;

A P.

Whi
of a
936
Proc
to ki
cauf
duC
and
160

T
and
in th
wha
figu
Wo

DO
000

001

002

003

004

005

006

007

008

009

010

011

Mechanical RECREATIONS.

CHAP. I.

Of Engines, by help of which we may Raise a very great Weight, with small Strength.

THE invention of all these Engines depend upon one Sole Principle; which is,
That, *The same Force that can lift up a Weight (for Example of 100 Pounds) to the height of one Foot; can lift up one of 200 Pounds, to the height of half a Foot: Or one of 400 Pounds to the height of a fourth part of a Foot; And so of the Rest, be there never so much applyed to it.*

And this *Principle* cannot be denied, if we consider that the *Effect* ought to be proportioned to the *Action* that is necessary for the Production of it: So that, if it be necessary to employ an *Action* by which we may raise a *Weight* of 100 Pounds, to the height of *two Feet*; for to raise one such to the height of *one Foot* only, this same ought to weigh 200 Pounds: For, it's the same thing to raise 100 Pounds to the height of *one Foot*; and again yet another 100 Pounds to the height of *one Foot*, as to raise one of 200 Pounds to the height of *one Foot*, and the same also, as to raise 100 Pounds to the height of *two Feet*.

Now the *Engines* which serve to make this *Application* of a *Force* which acteth at a *Great Space* upon a *Weight* which it causeth to be raised by a *Lesser*, are

Trochela, the Pulley.

The inclined Plain.

Cuneus, the Wedge.

Axis in Peritrochio, the Crane, Capsten, or Wheel.

Cochlea, the Screw.

Vetis, the Leaver.

And some others: For, if we will not apply, or compare *them* one to another, we cannot well number *more*: And if we will apply *them*; we need not instance in *so many*.

A

CHAP.

C H A P. II.

Of the Pulley PROBLEA.

LET A, B, C, be a Cord put about the Pulley D, to which let the Weight E be fastned; and first, supposing that two Men sustain, or pull up equally each of them, one of the Ends of the said Cord: It is manifest, that if the Weight weigheth 200 Pounds, each of those shall employ but the half thereof, that is to say, the Force that is requisite for sustaining, or raising of 100 Pounds, for each of them shall bear but the half of it.

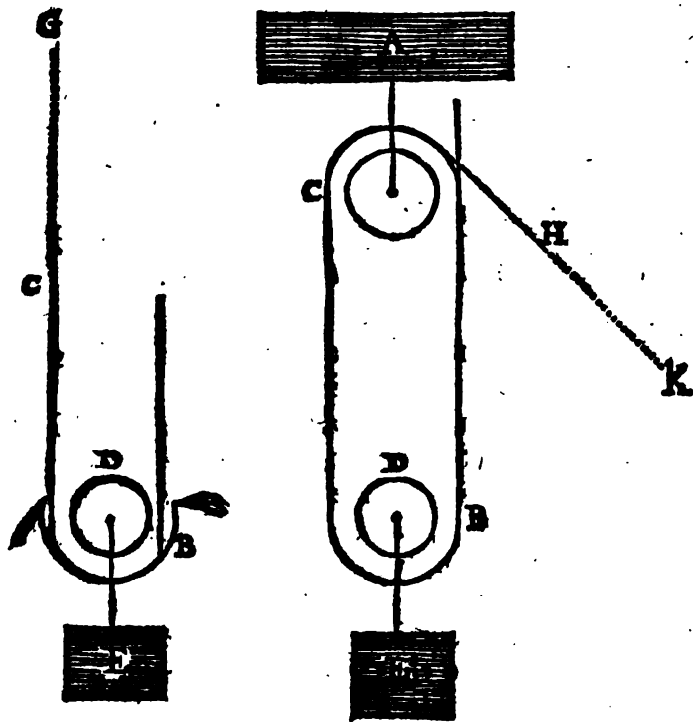

Afterwards, let us suppose that A, one of the Ends of this Cord, being made fast to some Nail, the other C be again sustained by a Man; and it is manifest, that this Man in C needs not (no more than before) for the sustaining the Weight E, more Force than is requisite for the sustaining of 100 Pounds; because the Nail at A, doth the same Office as the Man which we supposed there before. In fine, let us suppose that this Man in C do put the Cord to make the Weight E to Rise; and it is manifest, that if he there employeth the Force which is requisite for the Raising of an hundred pound to the height of two Foot, he shall Raise this Weight E of 200 Pounds to the height of one Foot; for the Cord A B C being doubled, as it is, it must be pulled two Foot by the end C, to make the Weight E rise as much, as if two Men did draw it, the one by the end A, and the other by the end C, each of them the length of one Foot only.

There is always one thing that hinders the exactness of the Calculation, that is the ponderosity of the Cord or Pulley, and the difficulty that we meet with in making the Cord to slip, and in bearing it:

But

M E C H A N I C A L.

But this is very small in comparison of that which raiseth it, and cannot be estimated save within a small matter.

Moreover, it is necessary to observe, that it is nothing but the redoubling of the Cord, and not the Pulley, that causeth this Force; for if we fasten yet another Pulley towards A; about which we pass the Cord A B C H, there will be required no less Force to draw H towards K, and so to lift up the Weight E, than there was before to draw C towards G. But if to these two Pulleys we add yet another towards D, to which we fasten the Weight, and in which we make the Cord to run or slip, just as we did in the first, then we shall need no more force to lift up this Weight of 200 Pounds, than to lift up 50 pounds without the Pulley; because that in drawing four Feet of Cord we lift it up but one Foot. And so in multiplying of the Pulleys, one may raise the greatest Weights with the least Forces. It is requisite also to observe, that a little more Force is always necessary for the raising of a Weight, than for the sustaining of it; which is the Reason why I have spoken here distinctly of the one and of the other.

C H A P. III.

Of the Inclined P L A N E.

IF not having more force than sufficeth to raise an hundred Pounds, one would nevertheless raise this Body F, that weigheth 200 Pounds, to the height of the Line B A, there needs no more, but to draw or rowl it along

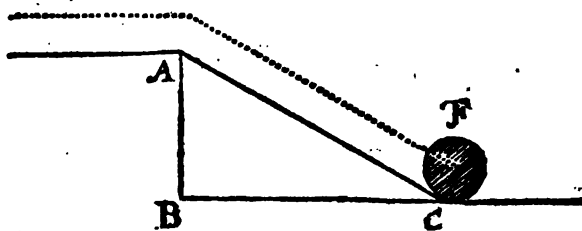

the Inclined Plane C A, which I suppose to be twice as long as the Line A B, for by this means, for to make it arrive at the Point A, we must there employ the Force that is necessary for the raising 100 Pounds twice as high, and the more enclin'd this Plane shall be made, so much the less force shall need to raise the Weight F: But there is to be rebated from this Calculation, the difficulty there is in moving the Body F, along the Plane A C; if that Plane were laid down upon the Line B C, all the parts of which I suppose to be equidistant from the Center of the Earth.

It is true, that this impediment being so much less as the Plane is more united, more hard, more even, and more polite, it cannot be likewise estimated but by guess, and it is not very considerable.

We need not neither much to regard that the Line B C, being a part of Circle that hath the same Center with the Earth, the Plane A C ought to be (though but very little) Curved, and to have the Figure of part of a Spiral, described between two Circles, which like-

R E C R E A T I O N S

wife have for their Center that of the Earth; for that it is not any way sensible.

C H A P. IV.

Of the W E D G E Cuneus.

THE force of the Wedge A B C D, is easily understood after that which hath been spoken above of the enclined Plane, for the force wherewith we strike downwards, acts as if it were to make it move according to the Line B D; and the Wood, or other thing and body that it cleaveth, openeth not, or the Weight that it raiseth doth not raise, save only according to the Line A C, insomuch, that the force wherewith one driveth or striketh this Wedge, ought to have the same proportion to the resistance of this Wood or Weight, that A C hath to A B: Or else again, to be exact, it would be convenient that B D were a part of a Circle, and A D and C D two portions of Spirals that had the same Center with the Earth, and that the Wedge were of a matter so perfectly hard and polite, and of so small Weight, as that any little force would suffice to move it.

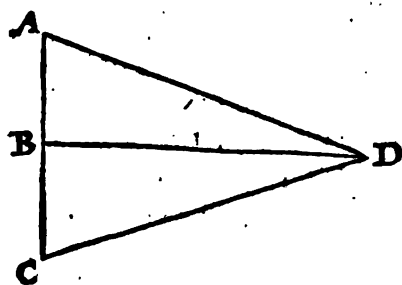

C H A P. V.

Of the C R A N E, C A P S T E N, or W H E E L, Axis in Peritrochio.

WE see also very easily, that the force wherewith the Wheel A or Cogg B is turned, which make the Axis or Cylinder C to move, about which a Cord is Rolled, to which the Weight D, which we would raise is fastned, ought to have the same proportion to the said Weight, as the circumference of the Cylinder hath to the Circumference of a Circle which that

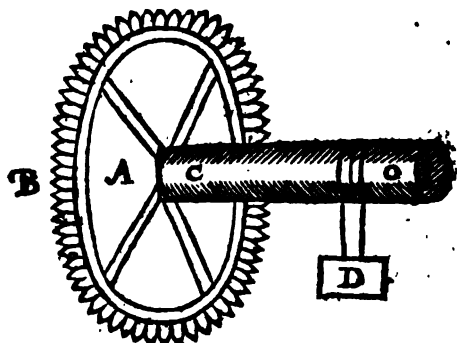

force

M E C H A N I C A L.

force describeth, or that the Diameter of the one hath to the Diameter of the other, for that the Circumferences have the same proportions as the Diameters: Insomuch, as the Cylinder C having no more but one Foot in Diameter, if the Wheel A B be six Feet in its Diameter, and the Weight D do weigh 600 pounds, it shall suffice that the force in B shall be capable to raise an 100 Pounds, and so of others. One may also, instead of the Cord that rolleth about the Cylinder C, place there a small Wheel with Teeth or Cogs, that may turn another greater, and by that means multiply the Power of the force as much as one shall please, without having any thing to deduct of the same, save only the difficulty of moving the Machine, as in the others.

Unto this Faculty of the *Wheel*, may be referred the Force of all those *Engines* which consist of *Wheels* with Teeth in them: And from hence also may be discerned the Reason why sundry *Instruments* in common use are framed, as *Hand-Mills*, the *Piercer*, the *Gimlet*, &c. as in the Figure. All which are but several kinds, of this fourth Faculty the *Wheel*; in all which *Instruments*, the Points A B C do represent the Places of the *Power*, the *Fulcrum* and the *Weight*. The *Power* being in the same proportion unto the *Weight* as B C is unto B A.

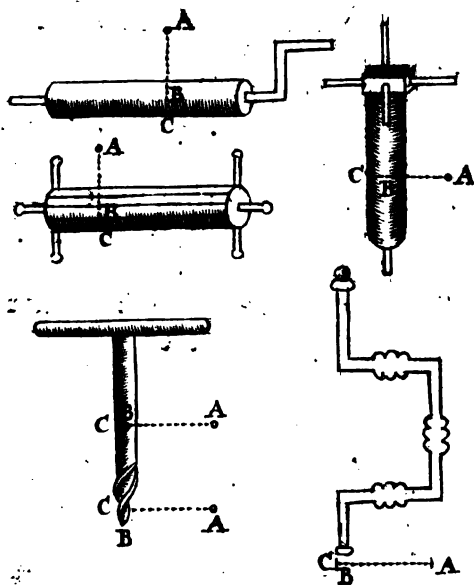

C H A P VI.

Of the S C R E W Cochlea.

When once the force of the Capsten, and of the inclined Plane is understood, that of the Screw is easie to be computed, for it is composed only of a Plane much inclined, which windeth about the Cylinder; and if this Plane be in such manner inclined, as that the Cylinder ought to make *v. gr.* ten turns, to advance forwards the length of a Foot in a Screw, and that the

the bigness of the Circumference of the Circle which the force that turneth it about doth describe be of ten Feet; forasmuch, as ten times ten are one hundred, one Man alone shall be able to press as strongly with this Instrument, or Screw, as one hundred without it, provided always, that we rebate the force that is required to the turning of it.

Now I speak here of pressing rather than of Raising, or removing, in regard that it is about this most commonly that the Screw is employed: but when we would make use of it for the raising of Weights, instead of making it to advance into a Female Screw, we joyn or apply unto it a Wheel of many Cogs, in such sort made, that if *v. gr.* this Wheel have thirty Cogs, whilst the Screw maketh one entire turn, it shall not cause the Wheel to make more than the thirtieth part of a turn, and if the Weight be fastned to a Cord, that Rolling about the Axis of this Wheel shall raise it but one Foot in the time that the Wheel makes one entire Revolution, and that the greatness of the Circumference of the Circle that is described by the force that turneth the Screw about be also of ten Feet, by Reason that 10 times 30 makes 300, one single Man shall be able to raise a Weight of that bigness with this Instrument, which is called the *Perpetual Screw*, as would require 300 Men without it.

Provided, as before, that we thence deduct the difficulty that we meet with in turning of it, which is not properly caused by the Ponderosity of the Weight, but by the force or matter of the Instrument, which difficulty is more sensible in it, then in those aforegoing, forasmuch as it hath greater Force.

MECHANICAL.

CHAP. VII.

Of the LEAVER Veils.

I Have deferred to speak of the *Leaver* until the last, in regard, that it is of all Engines for raising of Weights, the most difficult to be explained.

Let us suppose that CH is a Leaver, in such manner supported, at the Point O, (by means of an Iron Pin that passeth through it across, or otherwise) that it may turn about upon this Point O, its Part C describing the Semicircle ABCDE, and its Part H the Semicircle FGHIK, and that the Weight which we would raise by help of it were in H, and the force in C, the Line CO being supposed Triple of OH. Then let us consider, that in the time whilst the Force that moveth this Leaver, describeth the whole Semicircle ABCDE,

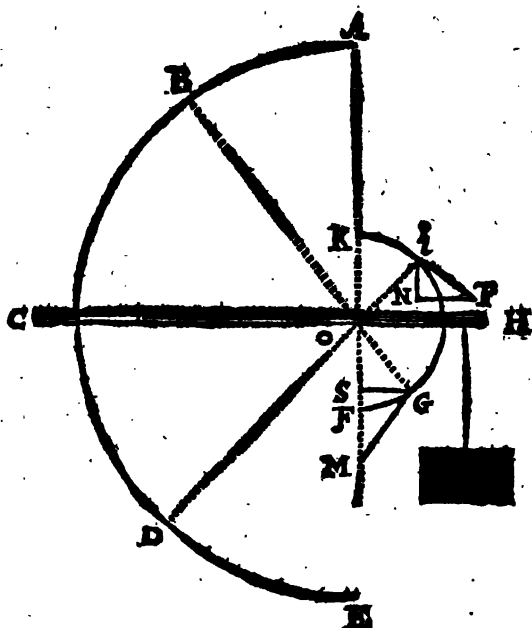

although that the Weight describeth likewise the Semicircle FGHIK, yet it is not raised to the length of this Curved Line FGHIK, but only to that of the Line FO K; inasmuch, that the proportion that the Force which moveth this Weight ought to have to its Potency, ought not to be measured by that which is between the two Diameters of these Circles, or between the two Circumferences, as it hath been said before of the Wheel, but rather by that which is between the Circumference of the Greater, and the Diameter of the Lesser. Furthermore, let us consider, that there is a necessity that this Force needeth not be so great, at such time as it is near to A, or near to E, for the turning of the Leaver, as then when it is near to B or to D, nor so great when it is near to B or D, as then when it is near to C; of which the Reason is, that the Weights there do mount less; as it is easie to understand, if having supposed that the Line COH is parallel to the Horizon, and that AOF cutteth it at Right Angles, we take the Point G equidistant from the Points F and H, and the Point B equidistant from A and C; and that having drawn GS Perpendicular to FO, we observe that the Line FS (which sheweth how

how much the Weight mounteth in the time that the Force operates along the Line A B) is much Lesser than the Line S O, which sheweth how much it mounteth in the time that the Force operates along the Line B C.

And to measure exactly what his Force ought to be in each Point of the Curved Line A B C D E, it is requisite to know that it operates there, just in the same manner, as if it drew the Weight along a Plain Circularly Inclined; and that the Inclination of each of the Points of this Circular Plain were to be measured by that of the Right Line, that toucheth the Circle in this Point. As for Example; when the Force is at the Point B, for to find the proportion that it ought to have with the Ponderosity of the Weight which is at that time at the Point G, it is necessary to draw the Contingent Line G M, and to account that the Ponderosity of the Weight is to the Force which is required to draw it along this Plain, and consequently to raise it, according to the Circle F G H, as the Line G M is to S M. Again, forasmuch as B O is Triple to O G, the Force in B, needs to be to the Weight in G, but as the third part of the Line S M, is unto the whole Line G M. In the self same manner, when the Force is at the Point D, to know how much the Weight weigheth at I, it is necessary to draw the Contingent Line betwixt I and P, and the Right Line I N Perpendicular upon the Horizon, and from the Point P, taken at discretion in the Line I P, provided that it be below the Point I, you must draw P N parallel to the same Horizon, to the end you may have the proportion that is betwixt the Line I P, and the third part of the Line I N, for that which is betwixt the Ponderosity of the Weight, and the Force that ought to be at the Point D for the moving of it; and so of others. Where, nevertheless, you must except the Point H, at which the Contingent Line being Perpendicular upon the Horizon, the Weight can be no other than Triple the Force which ought to be in C. for the moving of it: In the Points F and K, at which the Contingent Line being parallel unto the Horizon it self; the least Force that one can Assign, is sufficient to move the Weight. Moreover, that you may be perfectly exact, you must observe that the Lines S M and P M ought to be parts of a Circle, that have for their Center that of the Earth; and G M and I P, parts of Spirals drawn between two such Circles: And lastly, that the Right Lines S M and I N, both tending towards the Center of the Earth, are not exactly Parallels: And furthermore, that the Point H, where I suppose the Contingent Line to be Perpendicular unto the Horizon, ought to be some small matter nearer to the Point F than to K, at the which F and K the Contingent Lines are Parallels unto the said Horizon.

C H A P^r VIII

Of Archimedes his Cochlea, or Water Screw, and how
a Perpetual Motion hath been attempted to be performed
thereby.

I Do not think it fit in this place, to pass over with silence, the
Invention of Archimedes to raise Water with the Screw, which is
not only *Marvelous* but *Miraculous*: For we shall find, that the Water
ascendeth in the Screw continually descending: And in a given time,
with a given Force, doth raise an unpeakable quantity thereof. But
before we proceed any farther, let us declare the use of the Screw in
making Water to Rise: And

in the Figure let us consider
the Line I L O P Q R S H,
being an hollow Pipe of Metal,
wrapped or turned about
the Columb M K H, or a
hollow Channel, cut in the
Columb of Wood, and covered
with thin Plate of
Brass or Latten, through
which the Water may run.
If we shall put the end I into
the Water, making the
Screw to stand Leaning, so

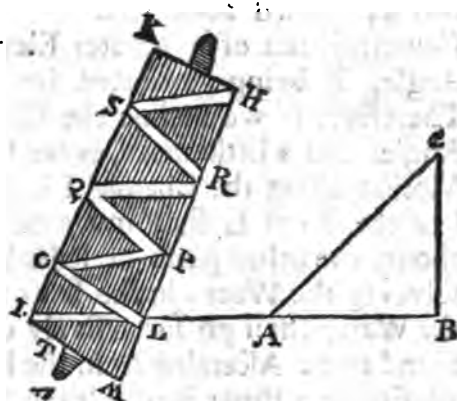

as the Point L may be lower than the first I, (as the Diagram sheweth) and shall turn it round about on the two Axes T and V, the Water shall run thorough the Pipe or Channel, till, that in the end, it shall discharge forth at the Mouth H. Now I say, that the water, in its conveyance from the Point I, to the point H, doth go all the way descending, although the Point H be higher than the Point I: Which that it is so, we will declare in this manner: We will describe the Triangle A C B, which is that of which the Screw H I is generated, in such sort, that the Channel of the Screw is represented by the Line A C, whose Ascent, or Elevation is determined by the Angle B A C, that is to say, if so be the Angle B A C be one third, or one fourth part of a Right Angle, then the Elevation of the Channel A C shall be according to one third, or one fourth of a Right Angle also: And it is manifest, that the Rise of that same Channel A C, will be taken away, debasing the Point C as far as to B, for then the Channel A C shall have no Elevation: And debasing the Point C a little below B, the water will naturally run along the Channel A C downwards from the Point A towards C. Let us therefore conclude, that the Angle A, being one third of a Right Angle, the Channel A C shall

R E C R E A T I O N S

shall no longer have any Rise, debasing it on the Point C, for one third of a Right Angle.

These things understood, let us unfold the Triangle about the Columb, and let us make the Screw B A E F G, &c. which if it shall be placed at Right Angles with the end B in the water, turning it about, it shall not this way draw up the water, the Channel about the Columb being Elevated, as may be seen by the Part B A, but altho' the Columb stand erect at Right Angles, yet for all that, the Rise along the Screw, folded about the

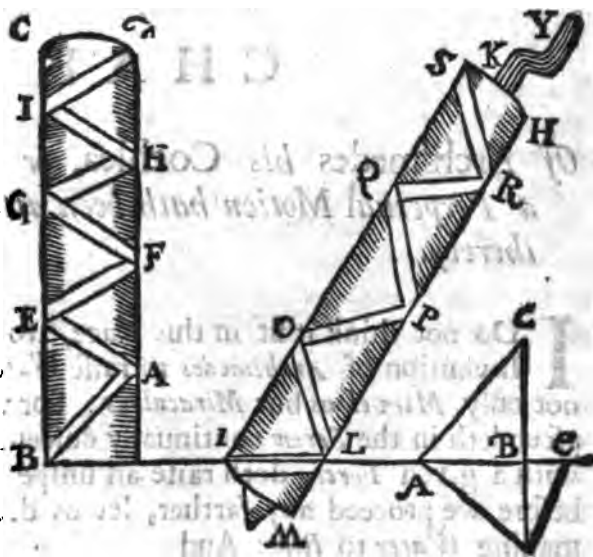

Columb is not of a greater Elevation, than of one third of a Right Angle, it being generated by the Elevation of the Channel A C: Therefore, if we incline the Columb but one third of the said Right Angle, and a little more, as we see I K H M, there is a Transition and Motion along the Channel I L: Therefore, the Water from the Point I to the Point L shall move descending, and the Screw being turned about, the other parts of it shall successively dispose, or present themselves to the Water in the same position as the part I L: Whereupon the Water shall go successively descending, and in the end shall be found to be Ascended from the Point I, to the Point H. Which, how admirable a thing it is, I leave such to judge who shall perfectly have understood it.

How it hath been by some supposed, that from this Water Screw a Perpetual Motion may be contrived:

For, say they, if there were but such a Water-Wheel made on this Instrument, upon which the Stream that is carried up, may fall; in its Descent it would turn the Screw Round, and by that means convey as much Water up, as is required to move it; so that the Motion must needs be continual, since the same Weight which in its fall does turn the Wheel, is by the turning of the Wheel carried up again.

Or, if water falling upon one Wheel would not be forcible enough for this effect; why, there might be two or three, or more, according as the Length and Elevation of the Instrument will admit; by which means the Weight of it may be so multiplied in the fall, that it shall be equivalent to twice or thrice that quantity of water which Ascends; as may be more plainly discerned by the Figure.

M E C H A N I C A L.

In this Figure L M at the bottom, represents a Wooden Cylinder with Helical Cavities cut in it; which at A B is supposed to be covered over with Tin Plates, and three water Wheels upon it, as H I K; the Lower Cistern which contains the water, being C D. Now this Cylinder being turned round, all the water which from the Cistern Ascends through it, will fall into the Vessel at E, and from that Vessel being conveyed upon the Water Wheel H, shall consequently give a circular Motion to the whole Screw: Or if this alone should be too weak for the turning of it, then the same water which falls from the Wheel H, being received into the other Vessel F, may from thence again descend on the Wheel I; by which means the force of it will be doubled. And if this be yet insufficient, then may the water which falls on the second Wheel I, be received into the other Vessel G, and from thence again descend on the third Wheel at K; and so for as many other Wheels as the Instrument is capable of. So that besides the greater distance of these three Streams from the Center or Axis, by which they are made so much heavier; and besides, that the fall of this outward water is forcible and Violent; whereas the Ascent of that within, is natural: Besides all this, there is thrice as much water to turn the Screw, as is carried up by it.

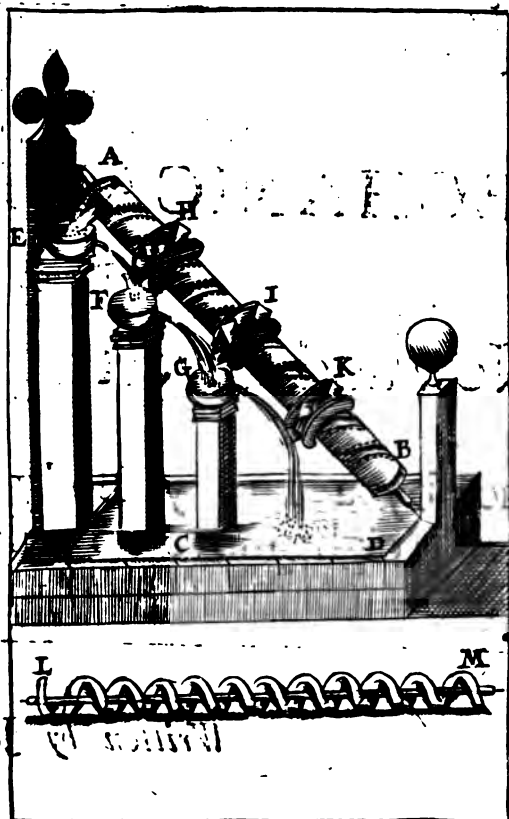

But on the other side, if all the water falling upon one Wheel would be able to turn it round, then half of it would serve with two Wheels. Although what is here said concerning the probability of effecting such a Motion, yet Trial and Experience have discovered the contrary, and found it wholly insufficient: And that,

First, For that the water that Ascends will not make any considerable Stream in the fall. And

Secondly, This Stream (though multiplied) will not be of force enough to turn about the Screw.

First, For that the water that Ascends will not make any considerable Stream in the fall. And

Secondly, This Stream (though multiplied) will not be of force enough to turn about the Screw.

A
MECHANICAL PARADOX:
 O R, A
New and Diverting Experiment.

Whereby a Heavy Body shall by its own
 Weight move up a sloping Ascent.

Written by J. P.

TH E Things necessary for this Experiment are, First, A Roller of Wood, turned in a *Lathe-Ins*, a Figure like as here is represented at A B, (*viz.*) of two Cones (or Sugar Loaves) abutting one against the other. Let the thickness in the middle (g h) be about
 5 or

5 or 6 Inches, the length AB about 3 times the thickness; at the end A & B may be left two little Pins turned. 2. You must provide two straight smooth Rulers about a Yard in length, and strong enough to bear the weight of the Roller. 3. Lastly, You must have three pieces of Wood to support the ends of the Rulers; the first about two or three Inches thick, the other two (to stand at D and F) must be thicker than this first by somewhat less than half the Diameter of the Roller; so that if the Roller be 6 Inches Diameter, the first piece of Wood 2 Inches, then let the other 2 pieces be about 4 Inches apiece. Being thus provided when you would try the Experiment, 1. Place the two thicker pieces upon a level Table almost the length of the Roller off of one another, as at DF, set the other piece of Wood almost the length of the Rular off of the other two. 2. Place the two Rulers with their ends upon the pieces of Wood in the manner as is represented in the Figure, with their lower ends near together, and the upper ends stradling. 3. Place the middle of your Roller between the two lower ends of the Rulers, and you will see (if you have placed all right) what you desire, *viz.* The Roller will of it self climb to the upper ends of the Rulers.

When you would divert any person with this Experiment, you may first put the Rulers Parallel, (or with lower ends as wide as the upper) and let it be seen how fast the Roller will run down the Descent; which will make it the more strange to see it afterwards climb the same Ascent, by only bringing the lower ends nearer.

The reason of this (seeming) Ascent of the Rhomb or Roller, is a real *Descent* or *Lowering* of its Center of Gravity, for tho' the way or line of the motion on the *Rulers* be an *Ascent*, yet the line which the Roller describes on its own surface is such, that every point of it approaches nearer to the Axis of the Rhomb, the opening of the Rulers causing the Contact to be nearer to the small ends of the two Cones; and consequently, nearer to their Axis: Whereupon the Axis of the Rhomb is so much lower at the top of the Rulers, as their Elevation comes short of the Semi-diameter of the Rhomb.

C H A P. IX.

Of other Engines, deduced from the former, for the moving of Great or Heavy Bodies; and of others for violent Motions.

Although great and heavy *Works* may be effected by many Hands, according to the Verse,

Multorum manibus grande levator opus:

And as may be instanced in the *Wild Indians*, who have performed with Hand Labour (they not having the knowledge of *Engines*) such strange matters, as the removing of Stones of an incredible greatness.

Arcoffa in his History of *Italy* relates, That he himself measur'd one at *Tiaguanaco* which was 38 foot long, 18 foot broad, and 6 foot thick. And he there also affirms, That in their stateliest *Edifices*, there were many other of far vaster Magnitude.

I. Of Pullies.

1. It is Reported of *Archimedes*, that with an Engine of *Pullies*, to which he applied only his *Left-hand*, he lifted up 5000 *Bushels* of *Corn* at once; and drew a *Ship*, with all its *Lading*, upon the Land.

2. The same *Archimedes* with an Instrument called *Helix*, which *Rivoltus* supposes to consist of many *Screws*, Launched into the Sea that great *Ship* which *Hero* had built, without any other help. And what is here said may in some measure be verified by the Experiment following.

3. How a Child, with a small Thread, or Sewing Silk, shall draw up a Weight of 3 or 400 Pounds.

Prodigious is the force of *Engines* made by the Multiplication of *Wheels*; but this feat may be performed by a Common Kitchen Jack for Roasting of *Meat*, provided the *Pullies* be well fixed, and the Cord of sufficient strength: For let a *Man*, or a greater *Weight*, be fastned where the Jack-Weight usually is, then let a small silk *String* or *Thread* (nay a *Horses Hair*) be tied fast to one end of the *Fly* of the *Jack*, which put into a *Childs* Hand, he can with it easily turn the *Fly* about, which he continuing so to do, shall draw the *Man* or *Weight* up to what height he pleaseth.

But if the number of *Wheels* were any Invented, it would draw up a far greater *Weight*; nay, it might be made of sufficient strength to pull

pull a great *Oake*, or other *Tree*, out of the *Ground* by the *Root*; Nay, as *Archimedes* affirmed, That the whole *Globe of the Earth* might be moved were there any other place to fix his *Engine* in.

4. How to contrive a *Ladder* by *Pullies*; whereby a *Man* may draw himself up to any assigned height.

For the performance hereof, there is required only an upper and a lower *Rundle* or *Pullies*. To the uppermost of these, at *A*, there should be fastned a sharp *Grapple*, or *Cramp* of *Iron*, which may be apt to take hold of any place where it lights: This part, being first cast up and fastned, and the *Staff DE*, at the neither end, being put betwixt the *Legs*, so that a *Man* may sit upon the other *BC*, and take hold of the *Cord* at *F*; it is evident, that the weight of the *Person* at *E*, will be but equal to half so much strength at *F*, so that a man may easily pull himself up to the place required, by leaning but little more than half of his own weight on the string *F*: But if the *Pullies* be Multiplied, this *Experiment* might be performed with less *Labour*.

II. Of the Sling.

The *Sling* is an *Instrument* or *Engine* of incredible force, and of such swiftness, that it exceeds that of a *Stone* thrown by the *Hand*, by how much the end of the *Sling* is farther off from the *Shoulder joint*, which is the *Center of Motion*; the *Victory* by *David* over *Goliath* is a sufficient Evidence of the force of this *Engine*. And again, in *Holy Writ*, we read of 700 *Benjamites* Left-handed that could *Sling* a *Stone* at a *Hairs breadth* and not miss. *Vegetius* relates, that it was usual this way to strike a *Man* Dead, and beat the *Soul* out of his *Body*, without so much as breaking his *Armor*, or fetching *Blood*. And it is likewise *Storied*, that there is a whole *Nation* among the *Indians*, who for their Excellency in the use of this *Engine* are Stiled *Baleares*; and they are so strict in *Teaching* this *Art* to their young *Children*, that the *Mother* will not give *Meat* to her *Child*, till (it being set at some distance) he could hit it with *Slings*.

C H A P. X.

Of Engines of War used among the Ancients.

Those among the *Ancient Romans* were principally of two sorts,

1. *Ballistæ*, Engines for Shooting or Casting of *Stones*.
2. *Catapultæ*, For the discharging of *Arrows*.

1. *Athenians*

1. *Athenus* mentions one of these *Balists*, that was proportioned into a *Stoep* of three *Talents* Weight, each *Talent* being 120 pound (saith *Vitruvius*) and so the whole 360 pounds.

2. It is reported by *Plutarch*, that *Archimedes* cast a Stone into one of *Marcellus* his Ships, which was found to weigh 10 *Talents*; that is, 1200 pound weight.

3. Among the *Turks* there have been used such Instruments, for *Nab. Naudem* tells us of one Bullet shot from them at the Siege of *Constantinople*, which was of above 1200 pound weight. This he affirms from the Relation of an Archbishop, who was then present and did see it.

4. Of the *Catapults*; some of them were proportioned to carry Spears of 12 Cubits long, which they would discharge with such force (saith *Amianus*) that the Weapons discharged from them were sometimes set on Fire by the swiftness of their motion.

5. It is related by Sir *Francis Bacon* in his 704 Experiment, that the Bows used now in *Turky* can strike an Arrow through a piece of *Steel* or *Brass* two Inches thick; being headed only with *Wood*, it will pierce *Timber* of 8 Inches thick, and hath pierced the sides of Ships.

6. *Bareley*, in his *Icon animorum*, affirms that he was an Eye-Witness how one of these Bows, with a little *Arrow*, did pierce through a piece of *Steel* three Fingers thick. These Bows (says the same Author) are somewhat like the *Long Bows* now in use with us, and bent by the immediate strength of one Man.

7. Mr. *John Greaves*, in his *Pyramidographia* reports, that he hath seen *Turkish Bows* of that strength, that they would pierce a Plank of 6 Inches thick.

C H A P. XI.

Of Automonata, or Self-Movers.

OF these there are principally two kinds, *viz.*

1. Such as are moved by something which is *Extrinsic* unto their own *Frame*, As *Mills* by *Water* or *Wind*.

2. Such as receive their Motion from something that does belong to the *Frame* it self, As *Glocks*, *Watches*, &c. by *Weights*, *Springs*, or the like.

Mills by *Wind* and *Water* are commonly known, and to what uses they serve; as for *Grinding of Corn*, *Making of Paper*, *Grinding of Brazill*, *Logwood*, &c. *Forging of Iron*, &c. But there are some other Motions by *Wind* and *Air*, though not so common, yet of Excellent *Curiosity*. As for Instance:

1. In *Egypt* there is a Statue of *Memnon* which makes a strange noise whenever the Sun begins to shine upon it; which Statue, *Strabo* affirms he hath both seen and heard it. Much like unto this was that *Musical Instrument* made by *Cornelius Dreble*, which being set in the Sun-shine, would of it self render a soft and pleasant Harmony; but being removed into the shade, would presently become silent.

2. *Cardano* makes mention of a Spit that may be turned (without the help of Weights) by the Motion of the *Air* that ascends the Chimney, and may be used for the Roasting of many a great Joint of Mear. In which contrivance there are these conveniencies: First, It makes little or no noise. Secondly, It needs no Winding up. Thirdly, It is much Cheaper than an ordinary Jack, it consisting only of a pair of *Sails*, one *Wheel*, to the *Axis* whereof the Jack-Line must be fastned. This may be an Engine of good use in many other Domestick Affairs, as in Reeling of Yarn, Rocking of a Cradle, &c.

Unto these kind of Motions may be added all those representations of *Living Creatures*, as *Birds* or *Beasts*, Invented by *Ctesibius*, which were for the most part performed by the motion of the *Air*, being forced up by Rarefaction by *Fire*; or else by compression through the fall of *Water*, which by possessing the place of the *Air*, did thereby drive it to seek for vent.

3. The late Invention of the *Wind Gun*, which is Charged by the forcible compression of *Air*, being injected through a *Syringe*, the strife and distension of the imprisoned *Air* serving by help of little *Falls* within to stop and keep close the *Vents* by which it was admitted; the force of which Gun is almost equal to our common Powder Guns: For *Mersennus* saith, that he hath often found by frequent Trials, that a *Lead-Bullet* from one of these Guns being shot against a Stone-Wall at 24 Paces distance, hath been beaten into a thin Plate.

4. The same Author (in the 31th Prop. of the same Book *Phænomena Pneumatica*.) whereby he will make the same Charge of *Air* to serve for the discharge of several *Arrows* or *Bullets* one after another, by giving the *Air* only so much room as may immediately serve for to impress a violence in sending away the Arrow or Bullet.

5. *Boterus* mentions that *Sailing Chariots* are commonly used in *Champion Countries*, as in *China*, by which a Man may Sail on the Land as well as by a Ship on the Water. Amongst these *Sailing Chariots*, that at *Scheveling* in *Holland* is very remarkable; it was made by the Directions of *Stephinus*, and is Celebrated by divers Authors. *Walchinius* affirms it to be of so great a swiftness for its Motion, and yet of so great Capacity for its Burthen, that it did far exceed the speed of any Ship; and that in some few hours space it would convey six or ten Persons 20 or 30 *German Miles*, and all this with very little Labour to him that sitteth at the Sterh. One *Peireskius* an inquisitive Man, Travelled to *Scheveling* for to see the Experience of this *Chariot*, and would often speak of the Extraordinary swiftness of it: And saith (among other Excellencies of it) that in two hours time it would pass from *Scheveling* to *Putten*, which are distant above 14 *Horaria Milliaria*; that is, more than 42 Miles.

6. Of this kind in *Holland* they have frequently other little Vessels for one or two Persons to go upon the Ice, having Sledges instead of Wheels, being driven by a Sail; the Bodies of them like little Boats, that if the Ice should burst they might yet safely carry a Man upon the Water, where the Sail would be still useful.

III. Of such Automata's that have their Motions from something within their own Frames.

1. Of the same kind with our *Clocks* or *Watches*, was that Sphere of Glass Invented by *Archimedes*, which did represent the Heavenly Motions, the Diurnal and Annual Motions of the *Sun*; the *Changes*, and other Aspects of the *Moon*, &c. This is frequently Celebrated in the Writings of the Ancients, particularly by the Epigramist *Claudius*, &c.

Jupiter in Parvo, &c.

Thus Englished.

IN a small Glass when Jove beheld the Skies,
 He Smiles, and thus unto the Gods Replies:
 Could Man so far extend his Studious Care,
 To mock my Labours in a Brittle Sphere,
 Heaven's Laws, Man's Ways, and Nature's Sovereign Right,
 This Sage of Syracuse Translates to sight.
 A Sol within on various Stars attends,
 And moves the quick Work unto certain ends.
 A feigning Zodiack runs his proper Year,
 And a false Cynthia makes new Months appear.
 And now bold Art takes on her to Command,
 And Rule the Heavenly Stars with Humane Hand:
 Who can admire Salmonean harmless Thunder,
 When a slight Hand stirs Nature up to Wonder.

This Spherical Engine I cannot think to be of *Glass*, but rather of *Brass* set on Work by Springs as the Movements of our *Watches*, and that it was inclosed in a *Case* of *Glass*, through which the Motions might be visible. In imitation whereof there was lately made one by *Cornelius Dreble*, and presented to King *James I.* of *England*. And like unto these *P. Ramus* Reports to have seen two at *Paris*, not of *Glass* but of *Iron*; one of which was brought by *Ruellius* the Physician from the Spoils at *Sicily*, and the other was recover'd by *Oromtius* from the *Gracian* Wars.

Of Walking or Flying Automata's.

1. Such were those strange Inventions attributed to *Daedalus*, Self-moving Statues, which (unless they were violently detained) would of themselves run away. *Aristotle* affirms that *Daedalus* did this by putting

putting *Quicksilver* into them; it is more likely he did it with *Wheels* and *Springs* within.

2. Of this kind likewise were *Vulcan's Tripodes*, Celebrated by *Homer*, that were made to move up and down the House, and fight with one another.

3. *Cardan* makes mention of an *Image* holding in its Hand a *Golden Apple*, beautified with many costly Jewels, which if any Man offered to take, the Statue presently shot him to Death; the touching of which Apple serving to discharge several short Bows, or other like Instruments couched in the Body of the Image.

4. *Walchinus* his *Iron-Spider* is very remarkable, which being but of an ordinary bigness, besides the outward similitude, which was very exact, had the same motions with a Living *Spider*, creeping up and down as if it had been alive.

5. I my self remember, and have often seen it, a Figure of a *Dutch Froe* made; the Case of Silver about 5 or 6 Inches high, one Arm by her side, and in the other a Silver Cup, which Cup being filled with Wine, and her Face directed to the party Drank to, who would softly Travel over the Table to the very Party; and when she came to the edge of the Table, she would there stand still till the party took the Cup out of her Hand and Drank to another; and so to a 3d, 4th, 5th or 6th Party, or more, one after another. And thus would she do for the space of half an hour, besides the times that she stood still between every Parties taking the Cup and Drinking.

6. There have been some Inventions also, which have been made, able to utter some certain Words; and such are some of the *Egyptian Idols* related to be: And such was the *Brazen Head* made by *Friar Bacon*. And that Statue, in the framing of which *Albertus Magnus* bestowed thirty years in the framing, who *Aquinas* coming to see, broke it, purposely, that he might boast, how that in one Minute he had ruined the Labour of 30 years.

Of Flying Automata's.

1. The Wooden *Dove* made by *Architas*, a Citizen of *Tarentem*, and one of *Platres* Acquaintance.

2. The Wooden *Eagle* framed by *Regiomontanus* of *Noremburg*, which by way of Triumph did fly out of the City to meet *Charles* the Fifth.

3. The *Iron Fly* made by the foresaid *Regiomontanus*, which, when he invited any of his Friends, would fly to each of them round the Table; and at length (as being weary) return unto his Master.

C H A P. XII.

Of the Magnificent Works of the Ancients, and wherein they exceed these of our Age.

I Shall here make a recital of some of the largest *Monuments* of this Nature which are Recorded in the *Ægyptian, Jewish, Grecian* and *Roman Histories*. And

1. Amongst the *Ægyptians*, we read of divers *Pyramids*. *Herodotus* mentions one of them Erected by *Cleopes* an *Ægyptian King*, wherein there was not one Stone less than 30 foot long.
2. *Amasis*, another *Ægyptian*, made himself a *House* of one entire *Stone*, which was 21 *Cubits* long, 14 *Broad*, and 8 *High*.
3. The forementioned *Amasis* is Recorded to have made the *Statue* of a *Finx*, or *Ægyptian Cat*, all of one *Stone*, whose *Length* was 143 foot, its *Height* 62 foot, and the *Compass* about it 102 foot.
4. *Pliny*, in his 37 Book, and 5th Chapter, Reports, that in one of the *Ægyptian Temples* Dedicated to *Jupiter*; there is an *Obelisque*, consisting of four *Emeralds*; which is 40 *Cubits High*, 4 *Cubits Broad* at the *Bottom*, and 2 at the *Top*.
5. *Dionorus S. cubus*, Reports, that *Sesoftris* an *Ægyptian King*, Erected in a *Temple* at *Memphis* Dedicated to *Vulcan*, two *Statues*, one for himself, the other for his *Wife*; both consisting of two several *Stones*; each of which *Statues* were 30 *Cubits High*.
6. Amongst the *Jews*, *Solomons Temple*, which for its *State* and *Magnificence*, (besides the great *Riches* of the *Materials*,) there were *Pillars* of *Brass* 11 *Cubits* high, and 12 *Cubits* about; and great and costly *Stones* for the *Foundation* of it; some of which *Josephus* tells us, were some 40, others 45 *Cubits* long.
7. The same *Josephus*, in the 6th Chap. of his 6th Book, tells us, that *Herod* built three *Famous Towers*, each 30 *Cubits* high, of *White Marble*, each *Stone* whereof was 20 *Cubits* Long; 10 *Broad*, and 5 *Thick*. These *Temples* were situate upon a steep rising *Ground*, and *Hills* upon that; upon the *Tops* of which *Hills* these *Towers* were Erected.
8. *Pliny*, in the 14th Chapter of his 36 Book Relates, that in the *Ephessian Temple* Dedicated to *Diana*, there were 127 *Columbs* made of so many several *Stones*, each 60 foot high; which *Stones* were digged out of the *Quarries* in *Asia*. This *Temple* was fired seven times, the last time by *Erostratus*, only to get himself a *Name* to *Postérité*.
9. Amongst the rest, the *Brazen Colossus* at *Roads* must not be forgotten, which *Pliny* in the 3d Chapter of his 34th Book, Reports to be Erected over a *River*, the two *Feet* whereof were fixed on either side of the *River*, and of such a *Magnitude*, that it was 70 *Cubits* high, the *Thumbs* of it being so big, that no *Man* could grasp one of them

them about with both his Arms : And it standing upright, a Ship might have passed betwixt the Legs of it, with all its Sails fully displayed: This *Statue* was thrown down by an Earth Quake, and the *Brass* of it did Load 900 Camels. Now, supposing a *Camels* Burthen to be 1200 Weight, the *Brass* in this *Statue* did contain 1080000 Pound Weighr.

10. But above all these (had it been effected) that would have taken place, which was by a *Grecian* Architect propounded unto *Alexander*, for to have cut the *Mountain Athos* into the Form of a *Statue*, which in his *Right Hand* should hold a *Town*, capable to receive ten thousand Men, and in his *Left*, a *Vessel* to receive all the *Water* that flowed from the several *Springs* in the *Mountain* : But *Alexander* (for what Reason I know not) embraced not the proposal, and so the World must rest satisfied without this *Wonder*. But had this *Statue* been Erected, according to the Proposal, let us a little enquire into the *Magnitude* of some of the *Members* of this *Statue*. (1.) For the *Statue* it self, that could not be higher than the *Mountain*, and the *Mountain* was not above one *Mile* in *Perpendicular height*. Therefore (2) The *Hand* must be the 10th part of the height, that is 500 foot, and consequently, (3.) The *Breadth* thereof 250 foot. And, (4.) The *Superficies* of the *Hand* would be 125000 *Square Foot*, in which ten thousand Men were to be received, and that it would afford, (5.) Each *Man* 12 Foot and a half of *Ground*. And, (6.) For the other *Members* you may compare their *Magnitudes* by what hath been said concerning the *Proportions* of the *Members* of *Mans Body*.

11. Amongst the *Romans*, we Read of a *Colossus* of *Brass*, made by the command, and at the Charges of *Nero*, which was 100 Foot high, which *Martial* calls *Syderius*.

Hic ubi Syderus proprius videt Astra Colossus.

12. It is storied of *M. Curio*, that he Erected two *Theatres* sufficiently capable of People, contrived moveable upon several Hinges. Sometimes there were *Plays* or *Shews* in each of them, neither being any disturbance to the other; and sometimes they were both turned about with the People in them, and the ends meeting together, did make a perfect *Amphitheatre*. So, that the *Spectators* which were in either of them might joyntly behold the same Spectacles.

13. At *Rome* were Erected several *Obeliskes*, each consisting but of one entire Stone; of which some were 40, some 80, and some 90 Cubits high. The choice of these were brought out of *Egypt*, where they were dug but of several *Quarries* there, and being there wrought into Form, were afterwards (with great Charge and Labour) conveyed to *Rome*.

14. In the year 1586, there was Erected an *Old Obeliske*, which had been formerly Dedicated to the Memory of *Julius Caesar*, it was one solid Stone, an *Ophite*, or spotted *Marble*; the *Height* of it was 117 foot, the *Breadth* at the bottom 12 foot, and at the Top 8 foot. Its whole Weight is Recorded to be 956148 Pounds, besides the heaviness of all those *Instruments* and *Utensils* that were employed about it, which (as it is thought) could not amount to less than 1040824 Pounds.

R E C R E A T I O N S

Pounds. This *Obeliske* was Transplaced at the Charges of *Pope Sixtus* the V. from the Left side of the *Vatican*, unto a more Eminent place, about a hundred foot off, where now it stands upon a Pedistal 12 foot and a half high; And the height of the Gilded Cross of Brass, at the Top of the *Obeliske* is 19 foot and a half high. This great Work was done in a few days; by five hundred Men.

15. *Phammitis* King of *Egypt*, built a Labyrinth on the South side of the Pyramids, which contained within one continued Wall 3500 Persons, (as *Herodotus* saith) and 12 Royal Palaces, all covered with Marble. The Labyrinth had only one Enterance, but innumerable turnings and windings, sometimes one over another; The Building whereof was more under ground than above, the Chambers so disposed, that the Doors upon their opening, did give a Report like a crack of Thunder. The main Entrance was all of white Marble, Adorned with stately Columbs and most curious Images. Being at the end, a pair of Stairs of 90 steps, conducted into a stately *Portico* supported by Pillars of *Theban* Marble, which was the Entrance into a Fair and Stately Hall (the place of their General Convention) all of Polished Marble set out with the Statues of their Gods.

16. The House of *Nero*, which he called *Domum Aurum*, by *Suetonius* is thus described: In the Porch was placed a *Coloffus*, shaped like himself of 120 foot high. The spaciousness of the House was such, that it had in it three Galleries, each of them a Mile long: A standing Pool like a Sea, beset with Buildings in manner of a City; Fields in which were Arable and Pasture Grounds, Vineyards and Woods, with a Multitude of Tame and Wild Beasts of all kinds: In the other parts thereof all things were covered with Gold, and distinguished with Precious Stones or Mother of Pearl: The Supping Rooms were Roofed with Ivory, moveable for the casting down of Flowers, and Pipes in them for the sprinkling of Oyntments: The Roof of the principal Supping Room was Round, which (like the Heavens) Day and Night moved round about. This House when he had thus finished and Dedicated it, he said then, that he began to live like a Man.

17. *Pancirollus* Reports, that *Ptolomeus Philopater* built a Ship, or Galley which was 280 Cubits in length, 52 Cubits from the Keele to the upper Deck: It had 400 Banks or Seats for Rowers; 400 Mariners, and 4000 Rowers, and on the Deck would contain 3000 Soldiers. *Plutarch* in the Life of *Demetrius* saith, there were Gardens and Orchards on the Top of it.

Of the Time, and Number of Men employed in the Building of some of these Magnificent Works.

1. In the making of one of the *Egyptian Pyramids*, we Read, that three hundred and sixty thousand Men were employed for twenty years. And *Herodotus* tells us, that one Million (or ten hundred thousand) of Men were as long in building another of them.

2. About the carriage of one Stone from *Amasis*, the distance of 20 days Journey, there was for three years together employed 2000 chosen Men *Governours*, besides many other under *Labourers*.

3. In

3. In the building of *Solomons Temple*, there were threeſcore and ten thousand Men that bore burthens, and 80 thousand *Hewers* in the *Mountains*.

4. The *Ægyptian Temple* was built by all *Aſia* joyning together : The 127 *Pillars* thereof were made by ſo many Kings, according to their ſeveral *Successions*; the whole Work being not finiſhed under the ſpace of 215 years.

5. In the building of one of the *Pyramids*, there was expended for the maintenance of the *Labourers* with *Radish* and *Onions*, no leſs than eighteen hundred Talents, which is reckoned to be about 470000 *i. e.* four hundred and ſeventy thouſand pound Sterling.

6. It is Reported, that the making of the *Rhodean Coloſſus* (before ſpoken of) did coſt 300 Talents.

7. *Cleopas*, an *Ægyptian King*, is reported to have been ſo deſirous to finiſh one of the *Pyramids*, that having ſpent all about it he was worth, he was forced at laſt, to proſtrate his Daughter, for neceſſary maintenance.

8. We Read of *Ramiſes*, another *Ægyptian King*, how that he was ſo careful to Erect an *Obeliſke*; about which he had employed twenty thouſand Men; that when he feared, leaſt through the negligence of the *Artificers*, or weakneſs of the *Engine*, the Stone might fall down and break, he tied his own Son to the Top of it, that ſo the care of his ſafety might make them more circumspect in their buſineſs.

An Account of the Heights of ſeveral Obeliſkes, Steeples, Pyramids and Pillars in the World, according to our English Meaſure, moſt of which are now in being.

1. *St. Pauls Steeple* in *London*, when the *Spire* was on it, (which was Fired by Lightning *Anno 1555*) the *Stone Work* was 260 foot high, and the *Spire* as much, which was 520 foot in all.

2. The Steeple at *Cremona* in *Italy*, is 528 foot high.

3. The *Ball* upon *St. Peters* in *Rome*, is 466 Feet.

4. The Steeple at *Roan* in *Normandy*, is 399 Feet.

5. The Steeple at *Strasburg* in *Germany*, is 431 Feet.

6. The Steeple at *Landhoven* in *Bavaria*, is 451 Feet.

7. The Steeple at *Medera* in *Italy*, is 279 Feet.

8. The *Tower Aſmel* in *Banomia* in *Italy*, is 316 Feet.

9. The *Capulo*, or *Lantborn* at *Genoa*, 324 Feet.

10. The *Higheſt* of the *Pyramids*, 1350 Feet.

11. The *Loweſt* of the *Pyramids*, 883 Feet.

12. *Boston Steeple* in *Lincolnſhire* all of Stone, and without any *Spire*, is 264 Feet.

13. The height of the *Obeliſke* in *Rome*, removed by *Sixtus* the V. is 78 Foot high.

14. The *Columb* or *Montment*, Erected in Memorial of the great Conflagration in *London*, *Anno 1666*, wherein 13200 Houſes, 89 *Parriſh Churches* were burned, all which ſtood upon 437 Acres of Ground. The *Monument* is of Stone; the *Pediſtal* whereof is 27 foot broad, and the height of the *Columb*, from the Ground (beſides the *Foundation*) to the Top of the *Flame*, is 202 Foot, the Circumference

rence of the *Shaft* is 47 $\frac{1}{2}$ Foot, its Diameter 15 Foot, and of the hollow *Cylinder* 9 Foot, with *Steps* up to the Top, and an hollow *Newel* from the Top to Bottom.

C H A P. XIII.

An Account of some such admirable Pieces of Work of several kinds, made by several eminent Artists, both Ancient and Modern; which have been by divers Historians and others related; and of some in this our present Age.

I. **R**egiomontanus, a Famous Geometrician of *Norimberg* made an *Eagle* of Wood, and a *Fly* of Iron. — This *Eagle* he put to Flight out of the *City*, which raised it self aloft into the Air, and met the Emperour *Maximilian* a good way off, as he was coming towards it; and having saluted him, returned again to the *City-Gates*. The *Fly*, at a Feast, flew forth of his Hand, and taking a Round about the *Table*, returned to his hand again. Of these two admirable Pieces of Wormanhip, (performed by Geometrical Proportion,) *Du Bartus* thus Writeth.

*Why should not I that Wooden Eagle mention,
A Learned Germans late admir'd Invention;
Which Mounting from the Fist that framed her,
Flew far to meet an Almain Emperour;
And having met him with her Nimble Train,
And wearied Wings; turning about again;
Follow'd him close, unto the City Gate
Of Norimberg, whom all their Shews of State,
(Streets hang'd with Arras, Arches Rarely Built:
Gray-headed Senate, and Youths Gallantries;)
Grac'd not so much, as did this one Device.*

Then he Describes the FLY as followeth,

*Once as the Artist, more with Mirth than Meat,
Feasted some Friends, whom he Esteemed Great:
From under's Hand an Iron Fly flew out,
Which having flown a perfect Round about,
With weary Wings Returned to her Master,
And (as Judicious) on his Arm he plac'd Her.
O! Divine Wit, that in the Narrow Womb
Of a small Fly, could find sufficient Room,
For all those Springs, Wheels, Counterpoise and Chains,
Which stood instead of Life, and Spur and Reins.*

2. Doctor

M E C H A N I C A L.

25

2. *Doctor Hackwell* in his Third Book of his Apology of the Power and Providence of God, in the Government of the VWorld—*Verstegan* in his Antiquities, Chap. 2.— And *Knowls* in his Turkish History, Pag. 513. Make mention of a Silver Sphere, which was sent by the Emperour *Ferdinand*, to *Solyman* the Great Turk: It was carried (Unframed) by Twelve Men, and Re-framed in the Grand Signior's Presence by the Maker of it; who also delivered him a Book containing the Mystery of using it. Of which Sphere *Du Bartus* thus VVriteth.

*Nor may we smother, or forget ungrately
The Heaven of Silver that was sent, but lately
From Fardinando, as a Famous Work
Unto Bizantium, to the Greatest Turk;
Wherein a Spirit, still moving to and fro,
Made all the Engine orderly to go,
And tho' th'one Sphere did always slowly Glide.
And contrary, the other swiftly Slide:
Yet still the Stars, kept all their Courses even
With the True Courses of the Stars in Heaven.
The Sun there shifting in the Zodiack,
His shining Houses never did forsake
His pointing Path. There in a Month his Sister
Fulfil'd her Course, and changing oft her Lustre,
And Form of Face, (now Larger) Lesser soon;
Follow'd the Changes of the other Moon.*

III. *Archimedes* the *Syracusan* Mathematician, who flourished *Anno Mundi* 3739, and before the Nativity of Christ 203, who is said to have composed a Sphere of Transparent Glass; representing to the Life the whole Frame of the Heavens; wherein the Sun, Moon and Stars, with their true Motions, Periods and Limits were shewed to the Sight, in such sort as if it were Natural: Of which Sphere *Claudianus*, an Eminent Poet in the time of *Theodosius* the Emperour, who was born at *Alexandria*, and flourished *Anno Christi* 390, Elegantly VVrote in his Epigrams; which is thus excellently Translated into English, by our Late English Poet, Mr. *T. Randolph*.

*Jove saw the Heavens, Fram'd in a little Glass,
And Laughing to the Gods, these Words let pass:
Comes then the Power of Mortal Cares so far;
In Brittle Orbs, my Labours Aged are.
The Statutes of the Poles, the Faith of things,
The Laws of Gods, this Syracusan brings
Hither by Art; Spirits inclos'd attend
Their several Spheres; and with set Motions bend
The Living Work; each year the feigned Sun,
Each Month returns the Counterfetted Moon;
And viewing now her World, bold Industry
Grows Proud, to know the Heavens his Subjects be,
Believe, Salmonius bath false Thunder thrown,
For a poor Hand is Natures Rival grown.*

D

IV. On

R E C R E A T I O N S

IV. One *Mark Scalios* a Black-Smith, in the year of Christ 1573, made a Lock, which consisted of eleven pieces of Iron, Steel and Brass, all which, together with a Pipe Key to it, weighed but one Grain of Gold— The same party also, made a *Chain of Gold*, consisting of 43 Links, to which he fastned the forementioned Lock and Key, and putting the Chain about the Neck of a Flea, which drew them all about with ease; and all these particulars weighed together but one Grain and a half.

V. One *Colicrates* would make Ants, Pismires, and other such like Creatures of Ivory, so small, that others could not discern the parts thereof one from another by the bare Eye, without the help of Glasses.

VI. One *Mermicides* (another excellent worker in Ivory,) made a Coach with four Wheels, and as many Horses; which a Fly might cover with her Wings,— He also made a Ship, with all her Tackling to it, which a small Bee would cover with her Wings.

VII. One *Cornelius van Drebbel*, a Dutch-man (in imitation of *Memnon's* Statue) made a kind of Organ that would make an excellent Symphony of it self, being placed in the open Air and clear Sun, without the Fingers of an Organist; but in a shady place it would yield no Musick, but only where the Sun Beams had the Liberty to play upon it.

VIII. One *Janellus Tarrianus*, a Great Mathematician, for to Recreate the Emperour *Charles* the V. would oftentimes delight him, by sending sometimes, Wooden Sparrows into the Emperours Dining Room, which would Fly about that, and return— Sometimes he would cause little Armed Men to Muster themselves upon his Table; and Artificially to move according to the Discipline of War.

IX. There was an Artificer in *Rome*, who made Vessels of Glas of such a Temper, that they were as little liable to be broken, as these of Gold or Silver. This Artificer made a Vessel of this pure sort of Glas, and presented it to *Tiberius Cesar*, the then Emperour: The Gift was received, and the Artist applauded; and that he might gain more Applause, he desires the Vessel again, and threw it with great Violence against the ground, whereby it received no more damage than the like Vessel made of the solideest Metal would have sustained thereby; at which *Cesar* was astonished: But the Artificer drew an Instrument out of his Bosome, wherewith he suddenly reduced it to its former shape: At the sight whereof, the Emperour was much moved, and enquired of the Artist, whither there were any other besides himself were privy to the like tempering of Glas? When he had told him no, he commanded his Head immediately to be stricken off: Saying, should this Artifice come once to be known, Gold and Silver would be of as little Value as Stones in the Street.

X. *Knolls* in his Turkish History, *Pag.* 1253 Relates, (long after the forementioned) *Viz.* in *Anno* 1610, that amongst other rare Presents then sent from the *Sophy* of *Persia* to the King of *Spain*, were Six Glasses of Malleable Glas, so exquisitely tempered, that they could not be broken.

XI. At *Dantzick*, a City of *Prussia*, one Mr. *Harrison* sent a Mill, which without help of Hands did saw boards, having an Iron Wheel which did not only drive the Saw, but did also hook in the boards, and

and drive them out, to and from the Saw—Dr. *John Dee*, in his Mathematical Preface before *Euclides Elements*, mentions the like seen by him in *Prague*; but whither the Mill before mentioned, or that which he see at *Prague*, moved by Wind or Water, is not set down by either of them.

XII. At the Mint of *Segoria* in *Spain*, there is an Engine that moves by water, so made, that one part of it distendeth an Ingot of Gold into that breadth and thickness, as is required to make Coyn of. It delivereth the Plate that it hath wrought, into another that Printeth the Figure of the Coyn upon it; and from thence it is turned over to another, that cutteth it according to the Print in due shape and weight. And lastly, the several Pieces fall into a Receiver in another Room; where the Officer, whose charge it is, finds it ready Coyned.

XIII. *Oswaldus Morbingerus*, made 1600 Dishes (or Platters rather) of turned Ivory, so small and little, so thin and slender, that all of them were included at once in a Cup turned out of a Pepper Corn of the ordinary size. This Piece was carried to *Rome*, and shewed to Pope *Paul* the V. who (by help of Spectacles) told them all distinctly.

XIV. *Johannes Baptista Ferrarius*, a Jesuit, had in his Possession, not long since, Cannons of Wood with their Carriages, Wheels, and other Military Furniture; of which 25 of these, and 30 Cups turned out of wood, were all at once contained in one Pepper Corn, which exceeded not the common bigness.

XV. *George Whitehead*, an English Man, made a Ship with all her Tackling, to move it self on a Table, with Rowers plying the Oars, a Woman playing on the Lute, and a little Whelp creeping on the Deck. *Schottus* relates this in his History of Man, Chap. 12.

XVI. About the year 1649 or 50, one *Fromanteel* an English Man (though of Dutch Parentage) made here in *London* for Sr. *Parson*, a little Figure in Silver, of a Woman in Dutch Habit, holding upright in her two Hands a Silver Cup, which would hold about the tenth part of a Pint of Wine. This Figure Sir *Parson* called his Froe (in respect of her Habit) and after Dinner, (for the Entertainment of his Friends) while his Servants were at their Dinner, would call for a Bottle of Wine, and his Froe to wait at his Table in his Servants Absence; which being brought, he would take the Cup out of his Froes Hands, and fill it with Wine; then drinking to one of his Friends on the other side of the Table, he would fill the Cup, and put it into the Froes Hands again, and directing her Face to the Person he drank to, the Froe would move of her own accord, cross the Table, to the party drank to; and when she came to the very edge of the Table, (till some part of the Skirt of her Garment hang over) she would there stand still; till the party drank to, took the Cup out of her Hands, and he drinking to another, filled the Cup again, and directed the Froe to whom he drank; to whom she would directly go as before; and would thus continue going throughout the Table. This Figure have I often seen, and been at the Table when the Experiment was put in practice.

XVII. There was one in Queen *Elizabeth's* days, that wrote the Ten Commandments, the Creed, the Pater-Noster, the Queens Name, and the Year of our Lord, within the Compass of a Penny; and gave with

it a pair of Spectacles, by help whereof the Queen did distinctly discern every Letter.

XVIII. Since which time, Namely in the Year of our Lord 1656, one *Abraham Switzer*, born in the Parish of *St. Andrews* in *Holborn*, *London*, (by profession an *Ingraver*, or *Cutter* of *Figures*, *Pictures* or *Schemes* to print in *Books*, in *Box* or other *VVood*.) Did write in a *Roman Hand* in words at Length, these following particulars; *Viz.* 1. *Every good and perfect Gift comes from above.* 2. *Lord teach us to Pray.* 3. *The Lords Prayer.* 4. *The Creed.* 5. *The 134 Psalm.* 6. *Lord Preserve the Church.* And Lastly, in the *Center*, or *middle*; (for it is written in a *Spiral* or *Serpentine Line*, with a *Red Line*, between every *Line*, for the better guiding of the *Eye* in *Reading*.) 7. *All the Figure of a Deaths Head*, which, one of the *Farthings* (then in use) would easily cover. This writing was written in the 61 year of his Age, and my own Father when I first shew'd it to him, being then 63 years of Age, could Read without Spectacles (for he never used any) and this piece of small writing I have this present time, *Febr.* 16. 1690 by me, to be seen of any that shall desire it.

XIX. One *Francis Alumnus* wrote the *Apostles Creed*, and the 14 first Chapters of *St. Johns Gospel*, in the *Compass* of a *Peny*, and this was done in full words, in the presence of the *Emperour Charles* the V.

XX. One *J. Rich*, an *English Man*, and an excellent *Steniographer*, did in the year 1671, take in *Short-Hand*, a *Sermon*, word for word, *Preached* before *King Charles* the II. at *Whitehall*, by a *Bishop* (whose Name I do not remember) in less than half a quarter of a sheet of Paper; and afterwards shewed it to the *Bishop*, and did distinctly Read it before him, who acknowledged it to be his, and that he did think there was not one word added or diminished, from what he then *Preached*: *VVhereupon* he wished he would present some piece of his Art to the *King*; upon which, he wrote the same *Sermon* in a little *Book* of Six Leaves of *Fine Paper*, and had it bound in *Crimson Sarcenet*, with *Silver Clasps* and *Corners* upon the *Cover*; all which *Book* and *Cover* was less than the nail of his little *Finger*; which *Book* he afterwards presented to the *King*.

XXI. *Wind Guns*, or *Muskets* are a *Rare* and *Late Invention*, which will shoot *Bullets* without *Powder*, or any thing else but *Wind*, or *Air* compressed in the bore of it, or injected by a *Spring*: These will discharge with as much force as others with *Powder*.

XXII. In the *Duke of Florentines Garden* at *Pratoline*, is a *Statue* of *Pan* sitting upon a *Stool*, with a *wreathed Pipe* in his *Hand*, and *Syrinx* beckoning him to play upon it. *Pan* putting away his *Stool*, and standing up, plays upon his *Pipe*; which done, he looks upon his *Mistress*, as expecting thanks from her, but his expectation being frustrated, he sits down with a *sad Countenance*.

XXIII. There is also in the same *Garden* another *Statue*, of a *Laundress* beating a *Buck*, and turning the *Cloaths* up and down with her *Hand* and *Battledore*, with which she beats them in the *water*.

XXIV. There is also the *Statue* of *Fame* loudly sounding her *Trumpet*. An *Artificial Toad* creeping up and down. A *Dragon* bowing down his *Head* to drink *water*, and then vomiting up again: *VVith* divers other pieces of *Art*.

XXV. In

XXV. In Cardinal *Farrar's* Garden at *Tivoli* near *Rome*, are the Representations of sundry Birds sitting on the Tops of Trees; which by secret conveyances of water through the Trunks and Branches of the Trees, are made to Sing and clap their Wings; but at the suddē appearance of an Owl out of a Bush, they immediately all become Mute and Silent: These were made by *Claudius Gallus*.

XXVI. In *Dantzick* in *Poland*, there was set up a rare Engine for weaving of four or five Webs at the same time, without any humane help, and would work Night and Day. This Invention was soon suppressed, and the Inventor secretly made away.

XXVII. *Hadrianus Junius* saw at *Mickland* in *Brabant*, a Cherry-Stone cut in the form of a Basket; wherein were fourteen pair of Dice, each with their several Spots, easily to be discerned by a good Eye.

XXVIII. In the year 1524, the City of *Colonia Agrippina*, was Painted with much exactness, and yet so little, that a Fly might cover it.

XXIX. In the Reign of *Anastacius Dicorus*, the Famous *Geometrician* and *Astronomer Proclus*, made burning Glasses of that admirable force; that therewith he burnt (at a great distance) the Ships of the *Myfians* and *Thrasians* that had blocked up the City of *Constantinople*.

XXX. One *Peter de Peene*, by Profession a Printer, made a Printing Press, of V Wood and Iron, with all the Members belonging thereunto, which was no bigger than a common Hour Glass, and in it was a forth of Letters, consisting of twelve Lines of Verses, written in the Praise of that Famous Art or Mystery of Printing, which this Press (as small as it was) would Print off; which Press my self have often seen in *London*: And this *Peter de Peene* was advised (he being but a poor Man) to put this Press into a Box, with some Ink and Letters, and go about the Countries to shew the Art of Printing to the Country People, and to Print their Names either in Red, Black or Gold upon Paper, Parchment, or Satten Ribband.

XXXI. The Duke of *Holsted* had made in the City of *Gottorp*, a double Globe of Copper, which was ten foot and a half Diameter, so that within it ten Persons might sit at a Table, which (with the Seats about it) hangeth at one of its Poles: In which Globe, a Man may see (by means of an Horizontal Circle within the Globe) how the Sun and Stars move of themselves through the Degrees of the Ecliptick; and their Rising and Setting regularly. The motion of this Globe exactly followeth that of the Heavens, and deriveth that motion from certain Wheels and Pinnions, driven by water, which is drawn from a Mountain not far off, and let in as it requireth More or Less.

XXXII. One *Linus*, an English man, of the Society of *Jesuits*, had a Vial Glass of water, wherein a little Globe did float, with the 24 Letters of the Alphabet described upon it: In the inside of the Vial was a Style or Index, to which the Globe did turn and move it self at the Period of every Hour, with the Letter which denoted the Hour of the Day or Night successively.

XXXIII. The same *Linus*, in Anno 1668, came over into *England*, (by way of Disguise, in Habit of a Country Gentleman) and in Anno 1669, did make in the Kings Privy Garden at *Whitehall*, a Pyramidical Dial. This Dial did stand upon a Pillar, or Pedistal of Stone,
and

and consists chiefly of Six Parts or Pieces, one less than another, and placed one above another, in form of a Pyramis. ——— The whole Fabrick contained 113 Dials, some Plain, some Concave, some Convex, some Upright, or Vertical; some Inclining, some Reclining; some Globular and Hollow; some covered with Glafs, &c. Some of these shew the common Hour of the Day, others the *Jewish*, others the *Babylonish*, others the *Italian* Hour. Some shew the Suns Declination; others the Suns Altitude, others the Suns Azimuth, others the Suns Rising, others the Suns Setting, others the Amplitude, some the Day of the Month, &c. Some by Fire, some by Water, some by Earth, and some by Air. In some of these Dials you shall see the Hour Lines, but no Stile, in some the Stile but no Hour Lines; in some neither Stile nor Hour Lines; and in some both Stile and Hour Lines. Infinite Varieties there were upon this Pyramis, too many here to recite; but for such as would know more concerning this Piece of Art, may have recourse to my Book of Dialling in *Folio*, *Pag.* 323, &c. where there is a Figure of the whole Pyramis, and a Description of every particular Dial upon it. This Pyramis stood in the Garden abovesaid about 18 Months, and then in a Frolick much Battered and Defaced, so that there is now nothing of it to be seen.

XXXIV. I saw, saith my Author, at *Legorn*, a Clock brought thither by a *German*, to be sold, which had so many Rarities in it, as I should never have believed, if my own Eyes had not seen it: For, (besides an infinite Number of strange Motions which appeared not at all to the Eye) you had there a company of Shepherds, some of which played on the Bag-Pipes, with such Harmony and Excellent Motion of the Fingers, as that one would have thought they had been alive; others Danced by Couples, keeping exact time and Measure; whilst others Leap'd and Capred up and down, with so much of Nimbleness, that my Spirits were wholly Ravished with the Sight.

XXXV. *Copernicus* made a Clock, in which there was not only to be heard a Number of different Noises, occasioned by its various Motions; but also (most exactly to be discovered) the circutions of all the Cœlestial Orbs; the distinction of Days, Months, and Years: There the Zodiack did explicate its Signs; so performing the Circle of the Year; there the playful *Ram* began the Spring; *Cancer* produces the Summer; *Libra* enriches it with Autumn; and *Capricorn* makes the Winter. Here also the Moon changes in the *Nones*, shines out more Bright in the *Ides*; and shamefully conceals her Conjunction with the Sun in the *Calends*. But, besides all these, there were produced into the Scene, upon the Entrance of every hour made shew of some Mystery of our Faith. The first Creation of Light, the powerful separation of the Elements, and all other intermediate Mysteries he had traced upon this Engine, even to the Great Eclipse that was when our Saviour suffered upon Mount *Calvary*, &c. for to insist upon the particulars were the Work of an Age.

XXXVI. There is a Clock at *Strasburg*, invented by *Cornelius Dapsardius* in the year 1571. Before this Clock stands a Globe on the Ground, shewing the Motions of the Heavens; Namely, of the Heaven carried about by the first Mover in 24 Hours; of *Saturn* in 30 years, of *Jupiter* in 12, of *Mars* in 2, of the *Sun*, *Venus* and *Mercury* in

in one, and of the *Moon* in a Month. In the Clock it self there be two Tables, shewing the *Eclipses of the Sun and Moon*, from *Anno 1573 to 1624*. There is also a third Table, which consisteth of three Parts: In the first Part, the Statues of *Apollo* and *Diana* shew the course of the year, and the Day thereof: The second shews the Year of our Lord, and of the World, the Hour and Minute of the Day. The third Part hath the Geographical Description of all *Germany*, and particularly of *Strasburg*, and the Names of the Inventor, and all the Work-Men. In the middle Frame of the Clock is an Astrolabe, shewing the Sign in which each Planet is every day; and there be the Statues of the Seven Planets, upon a round Piece of Iron lying flat; so that every Day that Planet which Denominates the Day, comes forth, the others being all hid; as upon Sunday the *Sun*, Monday the *Moon*, &c. And there is a Terrestrial Globe upon which the Hour; half Quarter and Minutes are shewed. There is also a Skull of a Dead Man, and the Statues of two Boys, whereof one turns the Hour-Glass every Hour when the Clock hath done striking; and the other puts forth the Rod in his Hand at each stroke of the Clock. There are also the Statues of the *Spring*, *Summer*, *Autumn* and *Winter*, and many Observations of the *Moon*. In the upper part of the Clock, are the Statues of four Old Men, which strike the Quarters of Hours; the Statue of Death coming out at each Quarter to strike, but being driven back by the Statue of *Christ*, with a Sphere in his Hand for three of the Quarters; but at the fourth Quarter, that of *Christ* goeth back, and that of Death striketh with a Bone in his Hand, and then the Chimes begin. On the Top of the Clock is an Image of a Cock; which twice in a day Croweth aloud, and chappeth his Wings. Besides, this Clock is Beautified with many Rare Pictures, and being in the inside of the Church carrieth another Frame to the outside of the Wall; wherein the Hours of the Sun, the Course of the Moon, the Length of the Day, and such other things, are set out with great Art.

XXXVII. The forementioned *John Fromanteele*, in the year 1649, did make a Table Clock with Springs, for Mr. *Dudley Palmer* of *Gray's Inn*, which besides the Hour and Minute of the Day, there was shewed upon the Dial Plate, the time of the *Suns Rising and Setting*, with the Length of the Day and Night; the *Suns Declination*, his Amplitude, his Declination, and other things relating to the Course of the Sun. This Clock gives one stroke upon a small Bell every Minute, and at every Quarter 2, 4, 6 and 8, strokes upon a bigger Bell, and upon a third Bell, at every Quarter is repeated the preceding Hour, and at every third Hour the Chimes went; which were so contrived, that they Rang 12 several times, by the shifting of three several Barrels, 4 Tunes upon each Barrel. This Clock I have often seen, and had some Hand in the making of it.

The End of the Mechanical Part.

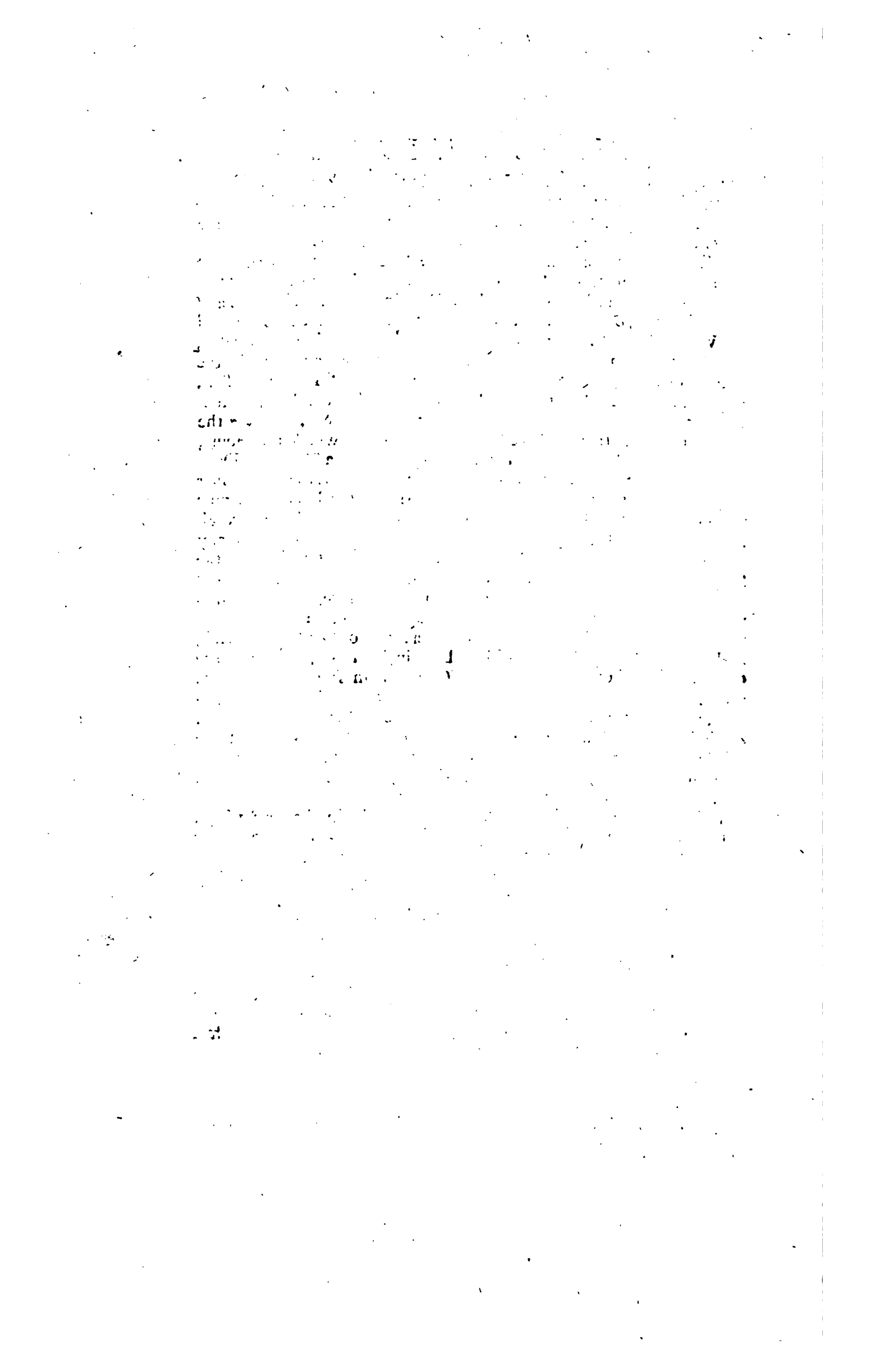

Statical RECREATIONS.

CHAP. I.

Of the Art STATICAL.

THE *STATICKS* is defined to be an *Art Mathematical*, which demonstrateth the Causes of *Heaviness* and *Lightness* of all Things: And of *Motions* and *Properties* belonging to *Heaviness* and *Lightness*.

So that by this Art, *Spheres* or other *Regular Bodies* may be *measured*, by having their *Quantity Ponderal*, according to any *Metal* and *Weight* assigned;) or, by having their *Quantity Dimentional*, (according to any assigned *Measure*;) there being the same *Mathematical Reason* of these two *Quantities*: And so they are by *Mathematicians* compared together in several kinds of *Bodies*; or divers kinds of *Bodies* are compared together among themselves in this two-fold *Reason* of *Quantity*: *Viz. Magnitude*, or *Dimension*; and *Gravity*, or *Ponderosity*. So that these two do proportionally answer each other, insomuch that the one may be deduced from the other; as *Gravity* from *Magnitude*, and *Magnitude* from *Gravity*: Or *Weight* from *Solid Measure*, and *Solid Measure* from *Weight*.

And from hence are deduced these following *Theorems* of *Marinus Gbesaldi*, in his *Tractate* called *Archimedes Promotus*.

CHAP. II.

Concerning the Ballance.

THE first Inventor of this *Statical Faculty*, commonly called *Libra*, or the *Ballance*, is attributed to *Astrea*, who is therefore Deified for the Goddess of *Justice*; and that Instrument is advanced among the *Twelve Celestial Signs*, and in that part of the *Zodiack*, to which, when the Sun cometh, it makes the *Days* and *Nights* of equal Length throughout the whole World.

S T A T I C A L

The chief End and Use of this Instrument, is for the distinction of several *Ponderosities*: For the understanding whereof it is to be noted, That, if the Length of the *Sides* in the *Ballance*, and the *Weights* at the *Ends* of them, be both mutably *equal*, then the *Beam* will be in an *Horizontal Situation*: But, if either the *Weights* alone be *Equal*, and not their *Distance*; or the *Distance* alone, and not the *Weights*; then the *Beam* will accordingly *decline*. As in the Figure.

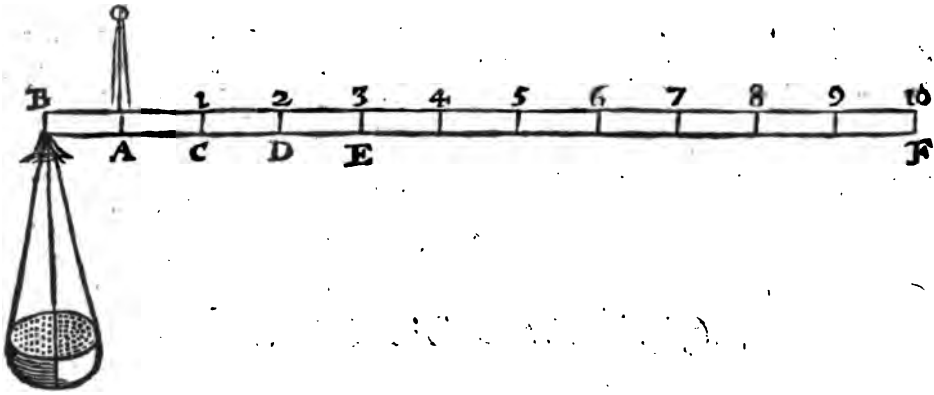

In which *Ballance*, suppose an *equal Weight* at C, to that at B, (both which Points are equidistant from the *Center A*) it is evident, that then the *Beam BF* will hang *Horizontally*: But if the *Weight* at C be unequal to that at B; or, if there be an *equal Weight* at D, or E, or any other of the unequal *Distances* noted upon the *Beam*; the *Beam* must then necessarily *decline*.

And with such a kind of *Ballance* as this, it is usual with *one Weight* only, to weigh, or measure, sundry different *Gravities*, whether *more* or *less* than that by which they are measured. And thus by the Figure here described, a Man may (with *one Pound* alone) weigh any other Body, or Substance, within *ten Pounds*; because the *heaviness* of any *Weight* doth increase proportionably to its *Distance* from the *Center*. And thus, *one Pound* at D, will equiponderate *two* at B, because the *Distance AD*, is *double* to that at A B. And for the same Reason, *one Pound* at E, will equiponderate *three Pound* at B; and *one Pound* at F, unto *ten* at B; there being the same disproportion between their several *Distances*.

This kind of *Ballance* is of great Antiquity; *Aristotle* giving it the Name of $\phi\acute{\alpha}\lambda\alpha\gamma\acute{\epsilon}$. It is also called *Romana Statera*; and now commonly, the *Stillyard*.

From what hath been said, it is easie to apprehend, how *false Ballances* may be composed; too often used, and so much condemned by *Salomon*, Prov. XI. 1. XVI. 11. XX. 10. 23. as being an *Abomination unto the Lord*. For, if the *Sides* of the *Beam* be not *equally* divided, As suppose one have *10 Parts*, and the other *11* of the same *Parts*, then any two *Weights* which differ according to this Proportion; as *Pappus* in his Third Book of *Mathematical Collections* observes: The *Heavier* being placed on the *Shorter Side*, and the *Lighter* on the *Longer*, will *Equiponderate*: And yet both the *Scales* being *empty*, shall be in *Equilibrio*, as in the Figure.

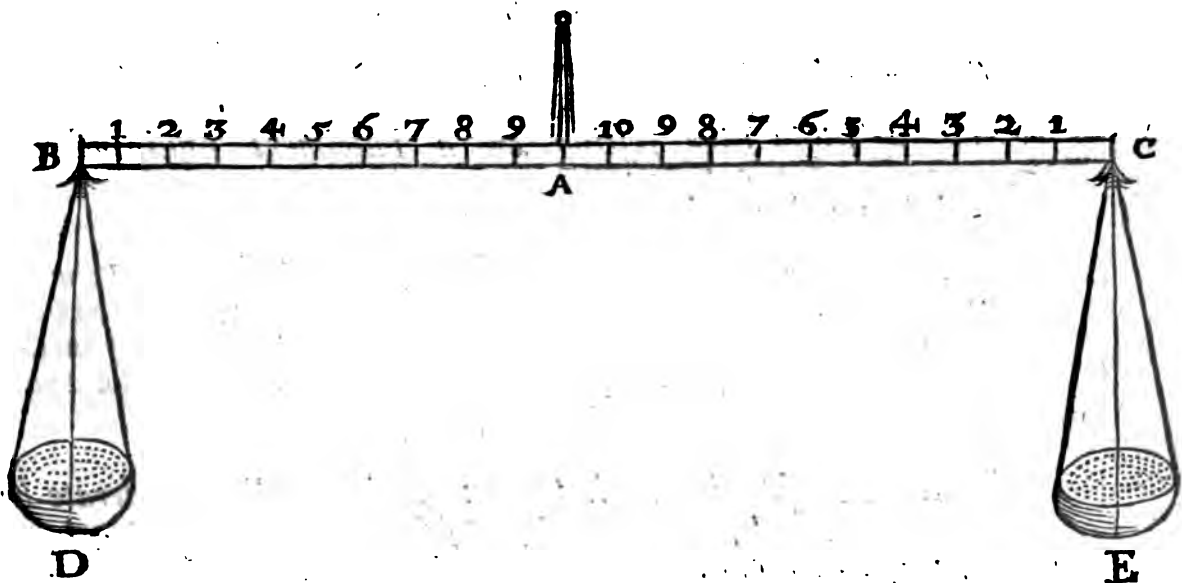

Suppose AC to have *eleven* such Parts, whereof AB hath but *ten*; and yet both of them (in themselves) of equal Weight: It is certain, that whether the Scales be empty, or whether in the Scale D we put 11 Pounds, and in E 10 Pounds, yet both of them shall *Equiponderate*, because there is just such a disproportion in the length of the Sides; AC being unto AB, as 11 is to 10.

How such deceitful *Ballances* may be discovered, is by changing the *Weights* into each other scale, and then the inequality will be obvious.

From these *Principles* here delivered, it is easie to conceive how a Man may find out the just Proportion of a *Weight*, which in any Point given, shall *equiponderate* to several *Weights* given, hanging in several places of the *Beam*.

Of these *Ballances*, some of them are so exactly made, (especially those that are in the *Say-Office* in the *Tower*, and at the *Goldsmiths Hall*;) as to be sensibly turned with the Eightieth part of a Grain. And *Capellus*, in his Book *De Ponderibus & Nummis*, mentions one at *Sedan*, that would turn with the Four hundredth part of a Grain.

Certain THEOREMS of Mr. *Michael Dary's*, concerning the *Construction* and *Use* of the SCALE of P O N D E R O S I T Y, (commonly called) the STILLYARD.

I. A *Right-Line* resting upon a *Fulciment* *Equiponderate* being proposed:

Then,

If any *Ponderosity* shall be applied to a *Point* of *Pendency* in that *Line*, it ought to be understood, That that *Ponderosity* is transplanted from the *Fulciment*, to that *Point* of *Pendency*: But if any *Ponderosity* shall be

A 2

with-

S T A T I C A L

withdrawn, or taken away, from a *Point of Pendency* in that *Line*, it ought to be understood, That that *Ponderosity* is transplanted from the *Point of Pendency*, to the *Fulciment*.

II. *A Right-Line resting on a Fulciment Equiponderate being proposed :*

Then,

If divers *Ponderosities* shall be *pendently* applied on sundry *Points* of that *Line*, so that the said *Line* be *Equiponderate* again; then the *Facts* (of each *Ponderosity*, by its transplantation from the *Fulciment*) on this side the *Fulciment*, are equal to the *Facts* on that side the *Fulciment*.

III. *A Right-Line resting on a Fulciment Equiponderate by divers Ponderosities, pendent in several Points of that Line, being proposed :*

Then,

If *two* of the *Ponderosities Pendent* shall be transplanted, so that the said *Line* shall be *Equiponderate* again; then the *Facts* of each *Ponderosity* by his *distance* run in transplantation, are equal.

IV. *If a Stillyard, or Scale of Ponderosity, or (as the Dutch call it) The Roman Beam, be true (i. e. doth give the Truth) in two Points, (the farther distant, the better.)*

Then,

It is *true* in all the *Points of Pendency* throughout, the *Divisions* being equal.

Unto what Uses these Ballances may be applied.

There are several Contrivances to make use of these Ballances :
as,

In measuring of the	{	Weight of <i>Blows</i> .
		Force of <i>Powder</i> .
		Strength of <i>Strings</i> .
		Condensed <i>Air</i> .
		Distinct Proportion of several <i>Metals</i> mix'd together.
		Different Gravity of divers <i>Bodies</i> in the <i>Water</i> , from what they have in the open <i>Air</i> .

With divers the like Ingenious *Enquiries*.

C H A P. III.

Of the BALLANCE of Signeur Galileo Galilei. In which, in Imitation of Archimedes in the Problem of the Crown, he sheweth how to find the Proportion of the Alloy of mix'd Metals; with the manner how the same Instrument is to be made. With some Annotations of Dominico Montovani upon the said Ballance.

AS it is well known, by such as take the pains to Read Old Authors. That *Archimedes* detected the Cheat of the Goldsmith in the Crown of *Heron*, King of *Sicily*, and Kinsman to that great Mathematician *Archimedes*; so I think it hitherto unknown what Method this great Philosopher observed in that Discovery.

For the Opinion that he did perform it, by putting the Crown into the Water, having first put into it such another Mass of *Pure Gold*, and another of *Silver* severally, and that from the differences in their making the Water more, or less rise and run over, he came to know the mixture, or Alloy of the *Gold* with the *Silver*, of which that Crown was compounded; seems a thing (if I may speak it) very *Gross*, and far from Exactness. And it will seem so much the more dull, to such who have read and understood the exquisite Inventions of so Divine a Man, amongst the Memorials that are extant of him; by which it is very manifest, that all other Wits are inferior to that of *Archimedes*. Indeed I believe, that Fame divulging it abroad, that *Archimedes* had discovered that same Fraud by means of the Water, some Writer of those Times committed the Memory thereof to Posterity; and that this Person, that he might add something to that little which he had heard by common Fame, did relate, that *Archimedes* had made use of the Water in that manner, as since hath been, by the generality of Men, believed.

But in regard I know that that Method is altogether Fallacious, and falls short of that Exactness which is required in *Mathematical Matters*, I have often thought in what manner, by help of the Water, one might exactly find the mixture of two Metals; and in the end, after I had diligently perused that which *Archimedes* demonstrates in his Book *De insidensibus Aqua*, and those others *De Equiponderantium*; there came into my Thoughts a Rule which exquisitely resolveth our Question; which Rule I believe to be the same that *Archimedes* made use of; seeing, that besides the use that is to be made of Water, the exactness of the Work dependeth also upon certain *Demonstrations* found by the same *Archimedes*.

The way is by help of a *Ballance*, whose *Construction* and *Use* shall be shewn by and by, after we shall have declared what is necessary for the knowledge thereof. You must know therefore, that the Solid Bodies that sink in the Water, weigh so much Less in the Water
that

than in the Air, as a Mass of Water equal to the said Solid, doth weigh in the Air; which hath been by *Archimedes* Demonstrated. But, in regard his Demonstration is very mediate, because I would not be over long; laying it aside, I shall declare the same another way. Let us consider therefore, that putting into the Water, *v. g.* a Mass of Gold, if that Mass were of Water, it would have no weight at all; for the Water moveth neither upwards nor downwards in the Water: It remains therefore, that the Mass of Gold weigheth in the Water only so much, as the Gravity of the Gold exceeds the Gravity of the Water. And the like is to be understood of other Metals. And because that Metals are different from each other in Gravity, their Gravity in the Water shall diminish according to several Proportions. As for *Example*: Let us suppose that Gold weigheth twenty times more than Water, it is manifest by that which hath been spoken, that the Gold will weigh less in the Water than in the Air, by a *Twentieth* part of its whole Weight. Now, let us suppose that Silver, as being less grave than Gold, weigheth *Twelve* times more than Water; this then weighed in the Water, shall diminish in Gravity the *Twelfth* part of the whole Weight: Therefore, the Gravity of Gold in the Water, decreaseth less than that of Silver; for that diminisheth a *Twentieth* part, and that a *Twelfth*. If therefore, in an exquisite *Ballance*, we shall hang a Metal at the one Arm, and at the other end a *Counter-poise*, that weigheth equally with the said Metal in the Water, leaving the Counter-poise in the Air, to the end it may equalate and compensate the Metal, it will be necessary to hang it nearer the Perpendicular or Cock.

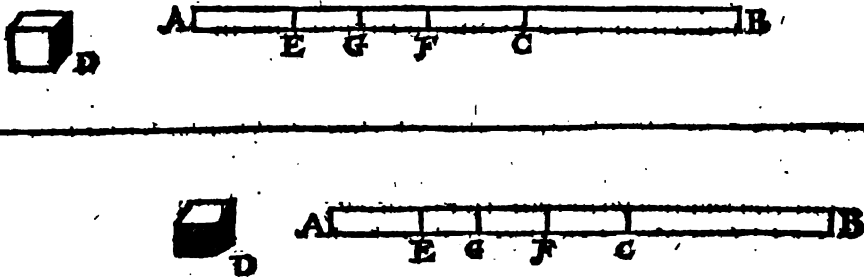

Example. Let the Ballance be *A B*, its Perpendicular *C*, and let a Mass of some Metal be suspended at *B*, counter-poised by the Weight *D*: Putting the Weight *B* into the Water, the Weight *D* in *A* would weigh more; therefore, that they may weigh equally, it would be necessary to hang it nearer to the Perpendicular *C*; as *v. g.* in *E*; and look how many times the Distance *CA* shall contain *AE*, so many times shall the Metal weigh more than the Water. Let us therefore suppose, that the Weight in *B* be *Gold*, and that weighed in the Water, it withdraws the Counterpoise *D* into *E*: And then doing the same with pure *Silver*, let us suppose that its Counterpoise, when afterwards it is weighed in the Water, returneth to *F*, which Point shall be nearer to the Point *C*, as Experience sheweth, because the *Silver* is less Grave than the *Gold*: And the Distance that is between *A* and *F*, shall have the same difference with the Distance *AE*, that the Gravity of the Gold hath with that of the Silver.

But

R E C R E A T I O N S.

7

But if we have a mixture of *Gold* and *Silver*, it is clear, that by reason it participates of *Silver*, it shall weigh Less than the *Pure Gold*; and by reason it participates of *Gold*, it shall weigh more than the pure *Silver*; and therefore being weighed in the *Air*, and desiring that the same Counterpoise should Counterpoise it, when that Mixture shall be put into the *Water*, it will be necessary to draw that Counterpoise more towards the Perpendicular *C*, than the point *E* is; which is the Term of the *Gold*; and more from *C* than *F* is, which is the Term of the pure *Silver*: Therefore it shall fall between the points *E* and *F*; and the Proportion into which the distance *E F* shall be divided, shall exactly give the Proportion of the two *Metals* which compound that *Mixture*.

As for *Example*; Let us suppose the Mixture of *Gold* and *Silver* to be in *B*, Counterpoised in the *Air* by *D*, in the undermost Figure which Counterpoise, when the Compound Metal is put into the *Water*, returneth unto *G*: I say now, that the *Gold* and the *Silver* which compound this *Mixture*, are to one another in the same Proportion, as the distance *F G* is to the distance *G E*. But you must know, that the distance *G F* terminated in the Mark of the *Silver*, shall denote unto us the quantity of the *Gold*; and the distance *G E*, terminated in the Mark of the *Gold*, shall shew us the quantity of the *Silver*: Infomuch, that if *F G* shall prove double to *G E*, then that Mixture shall be two parts *Gold*, and one part *Silver*: And in the same Method proceeding in the Examination of other *Mixtures*, one shall exactly find the quantity of the simple *Metals*.

The Composition of the Ballance.

To Compose the *Ballance*, therefore, Take a *Rod*, at least a *Yard* long (and the longer it is, the exacter the *Instrument* shall be,) and divide it in the midst, where place the *Perpendicular*; then adjust the *Arms*, that they may stand in *Equilibrium*, by Filing, or Shaving that less, which weigheth most; and upon one of the *Arms*, Note the *Terms* to which the *Counterpoises* of simple *Metals* return, when they shall be weighed in the *Water*; taking care to weigh the purest *Metals* that can be found, this being done, it remaineth that we find out a way, how we may with facility discover the proportion, according to which the distances between the *Terms* of the simple and pure *Metals* are divided by the *marks* of the *mixt Metals*; which shall be effected in this manner.

We are to have two very small *Wiers* drawn thorough the same *drawing Iron*, one of *Steel*, the other of *Brass*, and above the *Terms* of the simple *Metals* we must wind the *Steel Wire*; as for *Example*; Above the point *E*, the Term of the pure *Gold*, we are to wind the *Steel Wire*, and under it the other *Brass Wire*; and having made *Ten* folds of the *Steel Wire*, we must make *Ten* more with that of *Brass*; and thus we are to continue to do with *Ten* of *Steel*, and *Ten* of *Brass*, until that the whole space between the points *E* and *F*, the *Terms* of the *Pure Metals*, be full; causing those two *Terms* to be always visible and perspicuous: And thus the distance *E F* shall be divided into
many

S T A T I C A L

many equal parts, and numbered by *Ten* and *Ten*. And if at any time we would know the *Proportion* that is between *F G* and *G E*, we must count the *Wires F G*, and the *Wires G E*; and finding the *Wires F G* to be, for *Example*, 40, and the *Wires G E* 21: We will say, That there is in the *mixt Metal* 40 parts of *Gold*, and 21 of *Silver*. But here you must note, that there is some difficulty in the counting; for those *Wires* being very small, as it is requisite for exactness sake, it is not possible with the *Eye* to tell them, because the smallness of the spaces dazeleth and confoundeth the *Sight*: Therefore, to number them with facility; take a *Bodkin* as sharp as a *Needle*, and set it into a *Handle*, or a very fine pointed *Pen-knife*, with which we may easily run over all the said *Wires*; and this way, partly by help of *hearing*, partly by the *impediments* the *Hand* shall feel at every *Wire*, those *Wires* shall be counted; the *Number* of which, as I said before, shall give us the exact quantity of the *simple Metals* of which the *mixt Metal* is *Compounded*; taking Notice that the *simple* answer alternately to the *Distances*. As for *Example*, in a *mixture* of *Gold* and *Silver*; the *Wires* that shall be towards the *Term* of *Gold*, shall shew us the quantity of the *Silver*; and the same is to be understood of other *Metals*.

C H A P. I V.

Six Theorems, extracted out of Archimedes his Tract; Entitled, De Incidentibus Aqua: Very necessary for the better understanding of several Statical Experiments and Conclusions herein contained.

T H E O R E M I.

THE *Superficies* of every *Liquid*, that is consistant and [settled,] shall be of a *Spherical Figure*, which *Figure* shall have the same *Center* with that of the *Globe* of the whole *Earth* and *Waters*.

T H E O R E M II.

Solid *Magnitudes* that being of equal *Mass* with the *Liquid*, are also *Equal* to it in *Gravity*, being demitted into the [settled] *Liquid*, do so submerge in the same, as that they lie, or appear not at all above the *Surface* of the *Liquid*, nor yet do they *Sink* to the *Bottom*.

T H E O R E M

R E C R E A T I O N S.

9

T H E O R E M III.

Solid Magnitudes that are *Lighter* than the *Liquid*, being demitted into the [settled] *Liquid*, will not totally *Submerge* in the same; but some part thereof will lie, or stay, above the *Surface* of the *Liquid*.

T H E O R E M IV.

Solid Magnitudes that are *Lighter* than the *Liquid*, being demitted into the [settled] *Liquid*, will so far *Submerge*, till that a *Mass* of *Liquor*, equal to the *Part* *Submerged*, do in *Gravity* equalize the whole *Magnitude*.

T H E O R E M V.

Solid Magnitudes *Lighter* than the *Liquid*, being thrust into the *Liquid*, are repulsed upwards with a *Force*, as great as is the excess of the *Gravity* of a *Mass* of *Liquor* equal to the *Magnitude*, above the *Gravity* of the said *Magnitude*.

T H E O R E M VI.

Solid Magnitudes, *Heavier* than the *Liquid*, being demitted into the [settled] *Liquid*, are born downwards as far as they can descend; and shall be *Lighter* in the *Liquid*, by the *Gravity* of a *Liquid Mass* of the same *Bigness* with the *Solid Magnitude*.

Here followeth some other Theorems of Mr. William Oughtred concerning this matter.

T H E O R E M I.

IF four Pieces of *Metals*, whereof the *Third* is of the same kind with the *First*; and the *Fourth* of the same kind with the *Second*, are proportional: Their *Gravities* [or *Weights*] shall be Proportional.

T H E O R E M II.

IF there be four Pieces of *Metal*, whereof the *Third* is of the same kind with the *First*; and the *Fourth* of the same kind with the *Second*; and the *First* and *Second* be of equal *Greatness*; and the *Third* and *Fourth* of equal *Weight*; The *Weight* of the *First* and *Second* shall be reciprocally Proportional to the *Magnitudes* of the *Third* and *Fourth*.

B

T H E O R E M

STATICAL

THEOREM III.

IF Spheres of the same Matter, are in Gravity, or Weight, as the Cubes of their Diameters are in Magnitude. Et contra.

THEOREM IV.

PIeces of Metal, if they be of equal Magnitude, have their Weights in Direct Proportion, as is set down in the following Table: But if they be of equal Weight; they have their Magnitudes in Reciprocal Proportion.

CHAP V.

Concerning the Comparison of several Metals in Quantity and Weight.

Concerning this matter, I will give you the Proportions or Comparisons of the most Principal kinds of Metals in common Use; Namely of Gold \odot ; Quick-Silver φ ; Lead η ; Silver α ; Brass ξ ; Iron δ ; Tin γ ; according to the Experiments and Observations of Marinus Ghetaldus, in his forementioned Book; Entituled, *Archimedes Promotus*; as followeth, *Viz.*

\odot Gold	3990	}	ξ Brass	1890
φ Quick-Silver	2850		δ Iron	1680
η Lead	2415		γ Tin	1554
α Silver	2170			

Wherefore,

\odot Gold, hath such Proportion to	φ Quick Silver	} As	{	} Hath to	{	} Or in Decimals, as	}			
	η Lead							7	5	2850
	α Silver							38	23	2415
	ξ Brass							57	31	2170
	δ Iron							19	9	1890
γ Tin	19	8	1680							
		95	37			3990 to	1554			

Which Numbers Mr. Gunter in the 5th Chap. of his 3d Book of the *Sextor* hath expressed in the same Terms, and that in whole Numbers by changing the *Vulgar Fractions* of those Numbers into *Decimals*, putting the first Number 10000, whereas *Ghetaldus* puts it but 100; which Fractions *Dr. Wyband* in his *Taſcomeria* Pag. 201. hath put into a Table, both in *Direct* and *Reciprocal* Proportion; in respect of the *Equal Magnitudes* and *Gravities* of like Bodies of different Metals.

Proportion Direct.			Reciprocal Proportion.		
In like Bodies of several Metals and equal Magnitude: Having the weight of the one, to find the weight of the other.	⊙ Gold	10000	3895	Gold ⊙	In like Bodies of several Metals and equal weights, having the Magnitude of the one, to find the Magnitude of the rest. <i>The Converse of the former.</i>
	♀ Quick Sil.	7143	5453	Quick Sil. ♀	
	♁ Lead	6053	6435	Lead ♁	
	♁ Silver	5439	7161	Silver ♂	
	♀ Brass	4737	8222	Brass ♀	
	♁ Iron	4210	9250	Iron ♂	
	♁ Tin	3895	10000	Tin ♁	

Mr. *William Oughtred* in the 10th Chapter of his *Circles of Proportion*, says, that *Gberaldus* useth the *Ancient Roman Foot*, which by the Measure set down in his Book seemeth to be very little less than our usual *English Foot*, if not exactly the same. But, concerning this matter, let us make farther scrutiny.

C H A P. VI.

The Roman and English Foot Compared.

FOR farther Enquiry into this Matter, Mr. *John Graves*, in his *Treatise of the Roman Foot*, hath deduced from divers Observations and Experiments, by him made, with great Pains and Industry in his Travels, (especially in *Italy* and there at *Rome*;) more clearly expresses the *Dimension* or *Magnitude* of the *True Roman Foot*, not only *Linearly*, but also *Numerally*; in comparing it with the *Standard Measures* of *England*, and divers other *Nations*.

Of the several sorts of Roman Feet.

There are (as the above named Mr. *Graves* relates) several sorts of *Rom Feet*, used by divers Authors; amongst which, that which *Gberaldus* made use of was this next following.

1. *Pes Colotianus*, to be found in *Hortis Colotianis* in *Rome*: Which Foot, he comparing with our *English Foot*, findeth, that it containeth 967 such Parts, as our *English Foot* doth 1000: And so our *English Foot* to contain 1034. 13 such Feet, as the said *Pes Colotianus* (or *Roman Foot*) contain'd 1000: Whereby this *Roman Foot* should be exactly 11. 604 such Parts, as our *English Foot* is 12, *Viz.* 11. 604 Inches, wanting of our *English Foot* only 6, 396 Inches.

S T A T I C A L

2. There is another *Roman Foot* mentioned by the same Mr. *Graves*, which is that on the Monument of *Statilius*, In *Hortis Vaticanis* in *Rome*, which comes somewhat nearer to our English Foot than the former, for he observed it to be 972 such parts, as the English Foot is 1000 (and to be 1005. 17 of the *Pes Colotianus*, being 1000) whereby this Foot will be 11. 7 *ferè* of the English Foot, being 12, *Viz.* 11. 66 Inches; which wanteth only 0. 34 Inches of the English Foot.

3. A Third Roman Foot mentioned by him, is that of *Villalpan-dus*, deduced from the *Congius* of *Vespasian* in *Rome*, which he saith to be 986 parts of our English Foot, containing 1000. (and 1019. 65 of *Pes Colotianus*, being 1000) and so is 11. 8 of the English Foot being 12, *viz.* 11.8 Inches; which wants of the whole English Foot, only 0.2 Inches.

4. But the Ancient Greek Foot, doth (by his Observation) more nearly agree with our English Foot, than this last Roman Foot, being (by his Collation) 1007.29, of which the English Foot is 1000, which is hardly .c9 parts of an Inch, above a Foot English, it being 12.087 Inches English.

C H A P. VII.

Of Weights: And the Ancient Roman, and our English Weights compared.

AS for the *Weights* used by *Ghetaldus*, they are surely the *Roman Weights*, for he saith, they were the *Weights* used in his time, and those *Weights* have continued the same for many Ages. And Mr. *Graves* in his Discourse of the *Denarius*, puts this as an undeniable *Principle* and *Foundation*, from whence the *Weights* of the *Ancients* may be deduced [as the *Roman Foot* for the *Principle* of their *Measures*] having Collated with the *Troy Weights* from our *English Standard* for *Gold* and *Silver*, by *Grains* thereof saith; That the *Roman Pound*, both *Ancient* and *Modern*, containeth 5256 such *Grains*: And so the *Roman Ounce* both *Ancient* and *Modern*, 428 of the same *Grains*; the *Troy Pound* containing 5760 *Grains*; and so the *Troy Ounce* 480: Whereupon the *Roman Pound* and *Ounce* should be (in the least Terms) but $\frac{73}{80}$ of our *English Pound* and *Ounce Troy*. And so the Proportion of the *Roman Pound* and *Ounce*, to our *Troy Pound* and *Ounce*, as 80 to 73: Or in *Decimals*, as 10000 to 9125. And this is the commonly received proportion of the *Ounce Averdupois* to the *Ounce Troy*; and the contrary.

Moreover,

The *Pound* and *Ounce* used by *Mar. Ghetaldus* in his Book, Entituled, *Archimedes Promotus*, being compared with our *English Pound* and *Ounce Troy*, have such proportion as followeth; *Viz.*

One { Ounce } Of Ghetaldus Weight { 576 } Grains.
 { Pound } contains { 6912 }

And

R E C R E A T I O N S.

13

And

One { Ounce } Of our *Troy Weight* { 480 } Grains
 { Pound } contains. { 5760 }

Which Reduced to the least Terms, is, As 10 To 12.

And then,

As 10,

Is to 12 :

So is 480 Grains, or one Ounce or Pound of English *Troy Weight*,
 To 576 Grains, or one Ounce or Pound of *Ghetaldus Weight*.

Other Observations.

There is at this time in the *Tower of London*, (which hath been there ever since the *Reign of K. Henry the VII.*) in a Velvet Case ; an exact Cube of fine Iron, which by the Standard Ballance, there was found to Weigh of *Troy Weight* 4 Ounces, 3 Peny-Weight, 9.12 Grains.

And from hence by Experiment there made ; one Cubick Inch of Cast Iron will weigh 3.968 Ounces *Troy*, or 0.33068 Pound *Troy*.

And from hence,

A Sphere or Bullet of one Inch Diameter, of fine Forged Iron will weigh 2.18288 Ounces *Troy*, or 0.1819 Parts of a Pound *Troy Weight*.

And,

A Sphere or Bullet of 4 Inches Diameter, made of the same fine Forged Iron, will weigh 11.642 Pound, or 11 Pound 6 Ounces 2 Peny Weight, and 20 Grains *Troy*.

Also,

A Sphere of { Gold } Will weigh of { 2625.6 } Grains,
 1 Inch Dia- { Silver } { Troy Weight } { 1427.95 }
 meter of { Tin } { 1022.6 }

C H A P. VIII.

The Weight of Spheres of several Metals compared together.

AS For the Weights of *Metals* compared in *Spheres* of one and the same *Magnitude* in *Troy Weight* (wherein also are Observed the foresaid common proportions between *Troy* and *Averdupois* Weights) they are according to the Experiments of *Ghetaldus*, being deduced from his Comparitive Numbers, into the Parts of
Troy

S T A T I C A L

Troy Weight, and by him inserted into a *Table*; though not very precisely: Which *Table* *Dr. Wybard* in his *Tactometria* Pag. 237, hath put most Correct and Exact, and in *Grains* and *Millesimal* parts of a *Grain*: He supposing first (with *Ghetaldus*) a *Sphere* of *Gold* to weigh just one *Pound Troy*: And from thence the other *Metalline Spheres* of the same *Magnitude* to Weigh accordingly.

The T A B L E.					
	Ounc.	Pen. W.	Grain	Min.	Grain. Parts
⊙ Gold	12	00	00	00	5760.00
☿ Quick Sil.	8	11	10	6 fere	4114.285
♁ Lead	7	5	6	6	3486.316 fere
♃ Silver	6	10	12	12	3132.631
♄ Brass	5	13	16	8	2728.421
♁ Iron	5	1	1	7	2425.294
♃ Tin	4	13	11	5	2243.368

C H A P. IX.

Some Observations concerning the Worth, Weight, Magnitude, &c. of several Metals, and other Liquids.

I O F G O L D.

GOLD surpasseth all other Metals in these Respects, (1.) Greatness of Weight. (2.) Closeness of Parts. (3.) Fixation. (4.) Pliantness or Softness. (5.) Immunity from Rust. (6.) Colour or Tincture of yellow.

The Worth of Gold.

		l.	s.	d.	q.			
One	}	Pound Weight	Troy is worth	}	40	0	0	0
					3	6	8	0
					0	3	4	0
					0	0	1	2
		Ounce						
		Peny Weight						
		Grain						

This is the Price of ordinary Gold: Angel Gold is worth somewhat more; And Sovereign Gold somewhat less.

The

The Worth of Silver.

One	}	Pound Weight	} Troy is worth	l.	s.	d.	q.
		Ounce		(3	0	0	0
		Peny Weight		0	5	0	0
		Grain		0	0	3	0
				0	0	0	0

But of English Coin,

Of	}	Gold	} One Pound of Troy Weight	l.	s.	d.	q.
		Silver		} 40	18	4	3
		is worth		} 3	2	0	0

And by the foregoing Proportions.

Of	}	Gold	} One Pound Weight <i>Averdu-</i>	l.	s.	d.	q.
		Silver		} 49	13	8	1
		<i>pois</i> is worth		} 3	15	3	2

C H A P. X.

Of the Weight of Water, and other things, in Weight and Magnitude.

One Ounce $\left\{ \begin{array}{l} \text{Troy} \\ \text{Averdupois} \end{array} \right\}$ of Water contains $\left\{ \begin{array}{l} 1.8949 \\ 1.72556 \end{array} \right\}$ Inches.

One Ounce $\left\{ \begin{array}{l} \text{Troy} \\ \text{Averdupois} \end{array} \right\}$ of Water contains $\left\{ \begin{array}{l} 0.001096 \\ 0.00099859 \end{array} \right\}$ Feet.

One Pound $\left\{ \begin{array}{l} \text{Troy} \\ \text{Averdupois} \end{array} \right\}$ of Water is of solid $\left\{ \begin{array}{l} 22.7368 \\ 27.609 \end{array} \right\}$ Inches.

One Pound $\left\{ \begin{array}{l} \text{Troy} \\ \text{Averdupois} \end{array} \right\}$ of Water is of solid $\left\{ \begin{array}{l} 0.013158 \\ 0.115917 \end{array} \right\}$ Foot.

A Cubical Foot of Water weigheth of *Troy-Weight* 912 Ounces ; which is 76 *l. Troy*. And,

A Cubical Foot of Water weigheth of *Averdupois-Weight* 999.463 Ounces ; which is 62.588 *l.* That is, 62 *l.* 9 Ounces, 6 Drams and a half.

From those Proportions; divers *Statical Experiments* may be made by weighing several Metals, and other things, in the Water, and in the Air; The Measuring of Irregular Bodies, either in whole or in part, &c.— And although there may be some difference in the Weight of several Waters, as Rain-Water, River-Water, Fountain and Spring Waters;

Water, &c. yet the greatest difference that Dr. *Wybard* could find, was, but as 1.000000 to 1.002104, which is little above 2 in 1000.

Yet the difference which *Snellius* makes between the Gravity of Rain-water and others, is 1.000000 to 1.007522; but Dr. *John Wybard* makes it but as 1.000000 to 1.002104, which is little above $\frac{2}{1000}$, or 2 in a thousand. Which latter Proportion I do rather adhere unto, for that (to my own knowledge) the abovesaid Dr. *Wybard* made this following Experiment, *viz.* He caused a Glass to be blown on purpose which held about five and a half Wine-Pints, which he filled with clean Rain-water, which had settled some days, and filling the Glass therewith; he weighed it in a Standard Ballance in the Tower of *London* (or at Goldsmiths-Hall, I remember not well which) which would turn at the weight of one Grain, and he found the differences of the Weights of these several Waters from Rain-water to be as followeth, *viz.* in the abovesaid Quantity of five Pints and a half.

1. Snow-water he found to be lighter than Rain-water by 8 Grains.
2. *Thames*-water, and *Middleton's* New-River-water, to be Equal in Weight with Rain-water.
3. *Cheapside*-Conduit-water to be heavier than Rain-water by 14 Grains.
4. *Lamb's*-Conduit-water in *Grays-Inn-Fields* to be heavier than Rain-water by one Penny-weight, or 24 Grains.
5. The Water at the *Poltern-Spring* upon the *Tower-hill* heavier than Rain-water by 57 Grains. And,
6. *Crowders*-Well-water, by *Cripplegate-Church*, he found to weigh in the same Quantity 84 Grains.

Unto the foregoing Proportions, I shall here insert a Table not long since Published by Sir *Jonas Moor*.

A TABLE comparing, the Weight of Metals, Stones, Grains, Liquors, &c.

The Names of the Metals, &c.	The Weight of a Cubick Inch in Magnitude in Troy Weight.	The Magnitude in Inches and Decimals, as to one Ounce of Troy Weight.	The Weight of a Cubick Inch in the Water in Troy Ounces Dec. parts.
	Oun. Parts.	Inch. Parts.	Oun. Parts.
☉ Gold	9.91735	0.10083	9.33962
☽ Quick-silver	7.93388	0.12604	7.35615
♁ Lead	6.16198	0.16229	5.58425
☾ Silver	5.50083	0.18179	4.92310
♀ Copper	4.81342	0.20776	4.23569
♂ Hammer'd-Iron	4.27115	0.23380	3.69942
♁ Cast-Iron	3.96821	0.25252	3.39048
♃ Tin	3.96694	0.25208	3.38921
♁ Marble	1.59631	0.62644	1.01858
♁ Common Stone	1.09835	0.91045	0.52062
♁ Honey	0.79339	1.26042	0.21566
♁ Salt Water	0.57773	1.79490	0.00000
♁ Fresh Water and Wine	0.52773	1.77190	
♁ Oil	0.47603	2.10069	
♁ Wheat	0.37628	2.65757	
♁ Dried Oak	0.40745	2.45669	

S T A T I C A L

A TABLE of Foreign Weights and Measures compared with the *English*. By Sir Jonas Moore.

Names of Places.	The English Foot divided into 1000 equal parts.	The English Foot divided into 12 inches, and 108 parts of an Inch.	The Pound Averdupois divided into 100 parts.
E N G L A N D.			
London Foot	1000	0.120	100
F R A N C E.			
Paris Royal Foot	1.068	1.008	0.93
Lyons Ell	3.976	3.117	1.09
Boloyne Ell	2.076	2.008	0.89
XVII. P R O V I N C E S.			
Amsterdam Foot	.942	0.113	0.93
Amsterdam Ell	2.269	2.032	
Antwerp Foot	.946	0.113	0.98
Antwerp Ell	2.278	2.033	
Brill Foot	1.130	1.012	
Dort Foot	1.184	1.022	
Rynland, or Leyden Foot	1.033	1.004	0.96
Rynland, or Leyden Ell	2.260	2.031	
Lorraine Foot	.958	0.114	0.98
Mechalin Foot	.919	0.110	0.98
Middleborough Foot	.991	0.119	0.98
G E R M A N Y.			
Strasborough Foot	.920	0.110	0.93
Bremes Foot	.964	0.116	0.94
Cologne Foot	.954	0.114	0.97
Frankford ad Menam Foot	.948	0.114	0.93
Frankford ad Menam Ell	1.826	1.099	
Hamborough Ell	1.905	1.108	0.95
Leipsig Ell	2.260	2.031	1.17
Lubick Ell	1.903	1.098	
Noremberg Foot	1.006	1.001	0.94
Noremberg Ell	2.227	2.033	
Bavaria Foot	.954	0.114	
Vienna Foot	1.053	1.006	0.83
S P A I N and P O R T U G A L.			
Spanish Palm, or Palm of Castile	.751	0.090	0.99
Spanish Vare, or Rod, 4 Palms	3.004	3.000	

Names

<i>Names of Places.</i>	<i>The English Foot divided into 1000 equal parts.</i>	<i>The English Foot divided into Inches, and divided into 10th parts of an Inch.</i>	<i>The French Averdupois divided into 100 parts.</i>
Their Foot is one Third of the Vaire	1.001	1.00.0	
Lisbon Vaire	2.750	2.09.0	1.06
Gibraltar Vaire	2.760	2.09.1	1.03
Toledo Foot	.899	0.10.7	1.00
Toledo Vaire	2.685	2.08.2	
<i>I T A L Y.</i>			
Roman Foot on the Monum: of Colfutius	.967	0.11.6	1.23
Roman Foot on the Monum. of Statilius	.972	0.11.7	
Roman Palm for Building, whereof Ten make the Cauna	.732	0.08.8	
Bononia Foot	1.204	1.02.4	1.27
Bononia Ell	2.147	2.01.7	
Bononia Perch, whereof 500 make a Mile	12.040	12.00.5	
Florence Brace or Ell	1.913	1.11.0	1.23
Naples Palm	.861	0.09.6	1.43
Naples Brace	2.100	2.01.2	
Naples Cauna	6.880	6.10.5	
Genoa Palm	.830	0.09.6	1.42
Mantoua Foot	1.569	1.06.8	1.43
Milan Calamus	6.544	6.06.5	1.40
Parma Cubit	1.866	1.10.4	1.43
Venice Foot	1.162	1.01.9	1.53
<i>Other Places.</i>			
Dantzick Foot	.944	0.11.3	1.19
Dantzick Ell	1.903	1.10.8	
Copenhagen Foot	.965	0.11.6	0.94
Prague in Bohemia Foot	1.026	1.00.3	1.06
Riga Foot	1.831	1.09.9	
China Cubit	1.016	1.00.2	
Turin Foot	1.062	1.00.7	
Cairo Cubit	1.824	1.09.9	1.62
Persian Arah	3.197	3.02.3	
Turkish Pike, at Constantinople, the greater	2.200	2.02.4	0.86
The Greek Foot	1.007	1.00.1	
The Universal Measure	3.267	3.03.2	
<i>A Pendulum of the just length whereof will Vibrate 60 times in one Minute of Time.</i>			

CHAP. XI.

Experiments STATICAL.

Regard being had to what hath been before delivered about the *Ballance*; and also concerning the *Weights and Measures of England*, and those of the *Romans Ancient and Modern*; as also the *Proportions of the Weights of Metals and Waters*; several *Experiments* may be deduced; some whereof follow.

PROBL. I.

If a Sphere of Tin of one Inch Diameter, do Weigh 0.17753 l. Troy Weight (or 0.146285 l. of Averdupois Weight) as it hath been found so to do, by Dr. Wybares exact Experiment; What shall a Sphere of Tin weigh, whose Diameter is 7 Inches.

Spheres (and other Regular Bodies) are in Proportion one to another, as are the Cubes of their Diameters; Wherefore, Cube the Diameter given 7, it makes 343, which multiplied by 0.17753 l. the Product will be 60.89279 for the VWeight of the Sphere of Tin, whose Diameter is 7 Inches.

Or, If the VWeight of the Bullet were required in Averdupois VWeight, then multiply 0.146285 (the proportional Number for Averdupois VWeight) by 343 (the Cube of 7, the Diameter,) the Product will be 50.175755 l. Averdupois. So that a Sphere of Tin of 7 Inches Diameter will weigh

			lb.	Oz.	P. wt.	Gr.		
Of	}	Troy	}	VWeight	60.	10.	14.	16.
		Averdupois			lb.	Oz.	Dr.	1
			50.	2.	12.	4		

PROBL. II.

If a Sphere of Tin do Weigh 60.89279 Pound, or 1022.6 Grains Troy, what shall the Diameter of that Sphere be?

THE VWeight of a Sphere of Tin, whose Diameter is one Inch, was found to weigh 1022.6 Grains (as in Chap. VII.) which is 0.17753 Parts of a Pound Troy. Wherefore, divide 60.89279 lb. by 0.17753 lb. and the Quotient will be 343, whose Cube Root is 7, for the Diameter of a Sphere of Tin, which weigheth 60.89279 Pound.

PROBL.

P R O B L. III.

Having the Weight and Diameter of a Sphere of one sort of Metal given, to find the Length of the Diameter of a Sphere of the same Weight, of any other Metal; and also the Weight of a Sphere of the other Metal, whose Diameter shall be equal to the given Spheres Diameter.

THere is a Sphere of Tin, whose Diameter is 7 Inches, and it weigheth 60.89279 lb. Troy; what must the Diameter of a Sphere of Silver be that shall have the same VVeight.

I. *For the Diameter of the Silver Sphere, equal in Weight to the given Sphere.*

As 2170 (the Proportional Number for Silver,)
Is to 343 (the Cube of 7, the Diameter of the Sphere give)
So is 1554 (the Proportional Number for Tin)
To the Cube of the Diameter of the Silver Sphere;

Wherefore,

Multiply 1554, by 343, the Product will be 532022; which divided by 2170, gives in the Quotient 245.171; whose Cube Root is 6.228 Inches; and so much must the Diameter of a Silver Sphere be, that will Weigh 60.89279 Pounds Troy.

II. *For the Weight of the Silver Sphere, equal in Diameter to the Sphere given.*

As 1554 (the Proportional Number for Tin)
Is to 2170 (the Proportional Number for Silver)
So is the Weight of the Sphere of Tin 60.89279.
To the VVeight of the Sphere of Silver, 85.03054.

Multiply the given VVeight in Tin 60.89279, by 2170, the Product will be 132137.3543, which divided by 1554, the Quotient will be 85.03054, for the VVeight of a Sphere of Silver, whose Diameter is 7 Inches.

P R O B L. IV.

Being an Experiment of a Marble Bullet VVeighed in the Air, and in the VWater, by Dr. Wybard in Goldsmiths-Hall, and Mr. Jackson the Sea Master there.

They took a Marble Bullet, whose Diameter taken by a very fine pair of Calipers, they found to be 4.95 Inches; and so found the Solid Content to be 63.5 Inches, which Bullet VVeighed in the Air,

S T A T I C A L

Air, they found to Weigh 89.10 Ounces *Troy*: And afterwards weighed in the Water, they found it to Weigh 55.75 Ounces; the Difference is 33.35 Ounces.

Now, one Ounce *Troy* of Water is equal to 1.8949 Inches *Troy*; wherefore, divide 33.5 the solid Content in Inches, by 1.8949, the Water equal to one Solid Inch, and the Quotient will be 33.51 equal to the Solidity.

In like manner, if an irregular Figure, or Statue of the like matter should Weigh in the Air of *Averdupois* Weight 231 lb. And when Weighed in the Water, the Water overflowing, weighed 66 lb. Now (by what hath been said before) one Pound *Averdupois* of Water is equal to 27.609 Inches. Wherefore, divide 66.00000 lb, by 27.609, the Quotient will be 2.390.

The End of the Statical Part.

Postscript

How is it, that a Man sitting in a Chair, his Back to the back of the Chair, and his Legs by the fore frame of the Chair upon the Ground, cannot rise off the Chair except he bend his Body forward, or put his Legs backwards.

IN the Posture of Sitting, our Legs are supposed to make a Right Angle with our Thighs, and they with our Backs: As in the Figure.

Wherein, Let *A B* represent the Back; *B C* the Thighs; and *C D* the Legs. It is now evident, That a Man cannot rise from this Posture, unless, either the Back *A B*, do first incline unto *F*, to make an acute Angle with the Thighs *B C*; or else that the Legs *C D*, do encline towards *E*, which may also make an acute Angle with the Thighs *B C*: Or, lastly, unless both of them do decline to the Points *G* and *H*, where they may be included in the same Perpendicular.

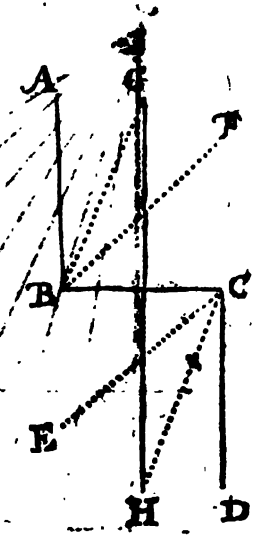

For the resolution of which, Philosophers give these two Reasons:

1. A Right Angle (say they) is a kind of Equality, and that being Naturally the cause of Rest, must needs be an impediment to the motion of Rising.

2. Because, when either of the Parts are brought into an acute Angle, the Head being removed over the Feet, or they under the Head, in such a Posture the whole Man is much nearer disposed to the form of standing, wherein all these Parts are in one straight Perpendicular Line, than he is by the other of Right Angles, in which Back and Legs are two Parallels; or that of turning these Right Angles into Obtuse, which would not make an erect Posture, but declining rather.

These are the Philosophical Reasons; the Geometrical may be these. Suppose *B C* to be a Lever, towards the middle of which is the place of the Fulcrum, Prop or Center, *A B* as the Weight, and *C D*, the Power which is to raise it.

Now the Body being situate in this Rectangular Form, the Weight *A B* must needs be augmented proportionably to its distance from the Center, which is about the middle of the Thighs; whereas, if we suppose either the Weight to be inclined unto *F*, or the Power *C D* to *E*, or both of them to *G* and *H*, then there is nothing to be lifted up but the bare Weight it self, which in this situation is not at all increased with any Addition by distance.

How

How upon a Plain Superficies, a Right Line being drawn; to draw another Line, which shall incline more towards that Right Line, yet never concur or meet with it in any part.

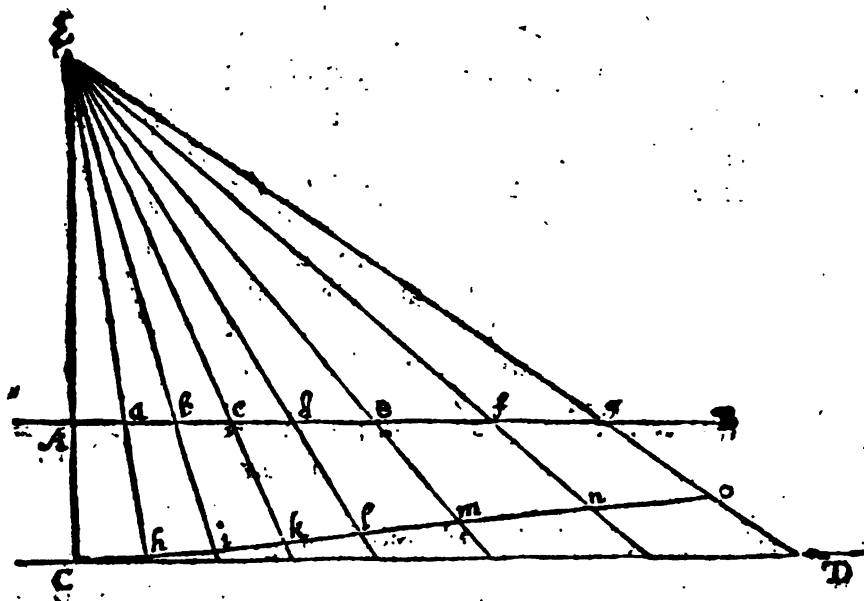

THIS seems to be against the Definition of Parallels; but you are to note the Line to be thus drawn, will not be a streight, but a Conoyd or mixt Line.

Let there be drawn a Right Line at pleasure, as AB, and another Parallel to it at any distance, as CD, at one end of the Line AB, as at A, Erect a Perpendicular at pleasure, as AE, and draw it down to C; then divide the Line AB, into what Number of Parts you please, equal or unequal, as at the Points a, b, c, d, e, f, g, &c. Then take in your Compasses the distance AC, and set it upon the respective Lines that are drawn from C, as from a, to h, from b to i, from c to k; from d to l, from e to m, from f to n, and from g to o. Lastly, draw Lines (or rather one continued Line with an even Hand, through the Points h, i, k, l, m, n, and o, and you will find that it still inclines nearer and nearer to the Line AB, but will never concur or meet with it.

Astronomical RECREATIONS.

CHAP. I.

A Brief View of the Principles of ASTRONOMY.

ASTRONOMY was Anciently called ASTROLOGY; But in after-times, this Synonymy ceased; the former tending only to *Divine* and *Prognosticate* of future *Events*, from the *Sight* and *Aspects* of the *Planets* and *Stars*. But the Latter (*Viz.* ASTRONOMY) of which I shall only Treat; is a *Science* which teacheth the *Laws* and *Rules*, whereby the *Motions* of the *Stars* and *Planets* are *Regulated* and *Determined*. As to the *Original* of this *Science*, it cannot be referred to a better *Patron* then *Admiration*: And so says *Gassendus*; *Originem ipsi fecit Admiratio*: For the *Ancients* admiring the *Splendor*, *Variety*, *Multitude* and *Magnitude* of the *Stars*, together with their *Constant* and *Regular Motions*; Transferred their *Admiration* into *Observation*, and that (in Process of time) into *Tables*, for the *Information* of *Posterity*.

CHAP. II.

Of the WORLD, and of such Places as in General it consisteth of.

THERE is nothing wherein the wonderful Power and Glory of God is more visibly expressed, than in the admirable Frame of this great Universe of Heaven and Earth. And the Reasons why most Men are no more affected with it, are; First, the Commonness of the things. Secondly, the ignorance of the Order and Causes thereof; whereas they that know any thing hereof, cannot but admire the Works of God herein; as we may see by the Prophet *David*, who so often speaks hereof in the *Psalms*. I shall therefore as briefly and plainly as I can shew you some part of these Wonders, and then I shall

A

shew

A S T R O N O M I C A L

shew you how these things are found out, and proved to be so, that you may not take them for vain Fancies, but in some measure see them to be Truths.

First, you must know that in this visible VWorld there are these Eminent parts which deserve a particular consideration.

1. The Globe of the *Earth*.
2. The Globe of the *Moon*.
3. The Globe of *Mercury*.
4. The Globe of *Venus*.
5. The Globe of the *Sun*.
6. The Globe of *Mars*.
7. The Globe of *Jupiter*.
8. The Globe of *Saturn*.
9. The Heaven of the fixed Stars.

Some add to these,

10. The Crystalline Heaven.
11. The first moving Heaven.

Now concerning the Number and Order of these several Spheres, Globes or Orbs, there are several Systems; Namely, (1.) That of *Pythagoras*. (2.) The *Platonick* and *Porphyrian* Systems. (3.) The *Egyptian* System. (4.) The *Copernican*. (5.) The *Tychonean*. (6.) The Hypothesis of *Risicalus*. Of these several Systems, there are two which are generally received; Namely, the *Ptolomick*, and the *Copernican*; concerning both which I shall briefly insist, for concerning these two, there hath been great *Disputes*, and therefore, I shall in this Place give you a brief Account of several *Objections* made against the one, (*Viz.* the *Copernican*;) with their *Answers*, and also *Arguments* for the Confirmation of the other, (*Viz.* The *Ptolomick*.) ——— And for the better understanding of the following Discourses, it will be necessary to acquaint you with what a material Sphere or Globe is, and what Circles, Lines and Points are described thereon, as imagined really to be in the Heavens.

C H A P. III.

Of a Material Sphere or Globe.

Theodorus, an Ancient and Learned Mathematician, who Wrote much of the Sphericks, thus defineth a Sphere or Globe. *Sphaera est solidum, una superficie contentum, in cujus medio puncto, in qua, omnes rectae lineae ductae ad superficiem ambientem sunt aequales.* That is, a Sphere or Globe is a solid Body, containing one Superficies; in whose middle there is a point, from which all right Lines drawn to the Superficies are equal.

Upon

R E C R E A T I O N S.

Upon the Superficies of this *Sphere* or *Globe* are described several *Circles* and *Points*, (which are only imagined in the Heavens) thereby the better to inform the Fancy; for by them (in the *Cælestial Globe*) the several Constellations of the *Fixed Stars* are limited, and their Situation denominated: And the same Circles described upon the *Terrestrial Globe*, do confine and bound the Zones and Climates.

These *Imaginary Circles* are in Number *Ten*; of which *Six* are called *Great Circles*, and *Four* or *Lesser Circles*: Those *Circles* are called *Great Circles*, which being drawn upon the *Globe*, do divide the Superficies thereof into two equal parts; and those are called *Lesser Circles*, which divide the Superficies of the *Globe* unequally.

C H A P. IV.

Of the Circles of the Sphere.

Every of the forementioned Circles hath a peculiar Name Attributed unto it; and the Names of

The Six Great Circles, are these.

- | | | |
|----------------------------|---|--------------------------|
| 1. <i>The Horizon.</i> | } | 4. <i>The Zodiack.</i> |
| 2. <i>The Meridian.</i> | | 5. } <i>The Colures.</i> |
| 3. <i>The Equinoctial.</i> | | 6. } |

Of these two *Colures*, the one is called the *Equinoctial Colure*, dividing the *Sphere* into two equal parts in the Points of *East* and *West*, and the other is called the *Solstitial Colure*, dividing the *Sphere* into two equal parts in the Points of *North* and *South*: So that these two *Colures* crossing one another at Right Angles in the *Poles* of the *World*, do divide the *Globe* into four equal Quarters.

The Four Lesser Circles are,

1. *The Tropick of Cancer*; Or the Northern Tropick.
2. *The Tropick of Capricorn*; Or the Southern Tropick.
3. *The Circle Artick*; Or the North-polar Circle.
4. *The Circle Antarick*; Or the South-polar Circle.

Besides these Circles, there are upon the Superficies of the *Globe*, other Points and Lines of special Note and Use: As,

1. The two *Poles* of the *World*, } North,
and
South,
2. } The Zenith, } Or Point in } Over our Heads.
3. } The Nadir, } the Heaven. } Under our Feet.
4. *The Poles* of the *Ecliptique*.
5. *The Ecliptique Line*, or *Via Solis*. And
6. There is another imaginary Line supposed to pass from *Pole* to *Pole*, through the Body of the *Globe*; and this Line is called, *the Axis*

A S T R O N O M I C A L

of the World, for that the Motion of the Heavens is wholly upon the Poles of the World.

Having thus given you the Names of the several *Circles, Lines* and *Points*, which are in the Heavens imagined, I will give you a brief Account of each particular, by which you may easily conceive how they are drawn upon the *Globe*:

C H A P. V.

Of the Use and Office of these Circles, Points and Lines.

I. *Of the HORIZON.*

THE *Horizon* is a great Circle of the Sphere, dividing the visible part of the Heavens from the not visible, that is, the lower Hemisphere from the Higher: As suppose you were at Sea, or upon a high Hill upon the Land, and looking round about you, you imagine that the *Skie* and *Water*, or the *Skie* and the *Earth* did meet and touch each other. Now this Line of Separation of the *Skie* and *Water*, or *Earth*, is the *visible Horizon*, and is that which is imagined to be in the Heavens.

Unto this Circle, when either the *Sun, Moon, Stars*, or any of the *Planets* do come on the East-part of the Heavens, they are then said to rise; and when any of them come to this Line on the West-part of the Heavens, then the *Sun*, or such a *Star* or *Planet* is said to set: So that the *Rising* and *Setting* of the *Sun, Moon* and *Stars*, are limited and bounded by this Circle.

2. *Of the MERIDIAN.*

The *Meridian* is a great Circle of the Sphere, which passeth through the *Zenith* and *Nadir* Points, and also thro' both the *Poles*, and divideth the *Horizon* into two equal parts in the Points of *North* and *South*, which passeth through the *Zenith* Point in the Heavens, which is directly over your Head, in what part of the World soever you are, and the *Nadir* (which is the point directly under your Feet, and opposite to the *Zenith*) and it also crosseth or divideth the *Horizon* in the *North* and *South* Point.

Unto this Circle, when the *Sun, Moon*, or any other *Star* or *Planet* cometh, it is said to be upon the *Meridian*, or at the highest it can be that Day or Night; so that when the *Sun* riseth towards the *East* in the Morning, it ascendeth higher and higher, till it cometh to this Circle, and then it is Noon; after which it descendeth lower and lower, till it set in the Evening in the West-part of the *Horizon*.

3. *Of*

R E C R E A T I O N S.

3. Of the *ÆQUINOCTIAL*.

The *Æquinoctial* is a great Circle, dividing the Sphere into two equal parts, and passeth through the *East* and *West* Points of the *Horizon*, and also through the *Meridian* in two Points, which are so far distant from the *Zenith* and *Nadir* Points, as the *Poles* are distant from the *Horizon*: So that the *Axis of the World*, which passeth from *Pole* to *Pole*, cutteth this Circle at Right Angles.

Unto this Circle when the *Sun* cometh (which is twice every year, Namely, about the tenth of *March*, and the twelfth of *September*) it maketh the Days and Nights of equal length through the whole World; for that at that time the *Sun* riseth due *East*, and sets due *West*; which at no other times of the year is doth, but rises and sets Northward of the *East* or *West* Points, from the tenth of *March* to the twelfth of *September*, and Southward of the *East* or *West*, from the twelfth of *September* to the tenth of *March* again.

4. Of the *ZODIACK*.

The *Zodiack* is a great Circle, dividing the Sphere or Globe into two equal parts, in the *East* and *West* Points of the *Horizon*, and cutteth both the *Horizon* and *Equinoctial* at oblique Angles; for it cuts the *Horizon* at an Angle equal to the *Sun's* greatest *Meridian Altitude*, in any *Latitude*, and the *Æquinoctial* at an Angle equal to the *Sun's* greatest *Declination*. This Circle is called by some, *The Girdle of the World*, it having imbroidered (as it were) upon it, the Figures of the 12 *Cælestial Signs*. But through the middle thereof, there is a Line, which is called the *Ecliptick Line*, or *Via Solis*, for that the *Sun* in his motion never deviates from this Line (though the other Planets do more or less.) The *Poles* of this Circle are upon the *Meridian*, so far distant from the *Poles* of the World, as is the *Sun's* greatest *Declination*.

5. And 6. Of the two *COLURES*.

The two *Colures* are two great Circles, passing through the *Poles* of the World, and there cutting each other at right Angles: The one of these *Colures* cutteth the *Ecliptick Line* in the Points γ and α , and is called the *Equinoctial Colure*: The other cutteth the *Ecliptick* in the Points δ and ψ , and is called the *Solstitial Colure*.

When the *Sun* is in that Sign or Point of the *Ecliptick*, which meeteth with the *Equinoctial Colure*, which is in the first scruples of γ or α , then are the Days and Nights equal: But when the *Sun* cometh to those Points of the *Ecliptick*, which are cut by the *Solstitial Colure*, which are in the beginning of δ and ψ ; then the *Sun* being in δ , it maketh the longest day to all the Northern, and the shortest day to all the Southern Inhabitants of the World: And being in *Capricorn*, it maketh the shortest day to the Northern, and the longest to the Southern In-

7. Of the two TROPICKS.

The *Tropicks of Cancer and Capricorn*, are two Circles drawn upon the Superficies of the Globe, parallel or equidistant from the *Equinoctial*, on the North and South-side thereof at 23 Degrees, 31 Minutes distance therefrom; the one is called the *Northern Tropick*, the other the *Southern*. And between these two *Tropicks*, is seated that part of the World which is called the two *Torrid Zones*.

8 And 9. Of the ARTICK and ANT-ARTICK Circles.

These are two small *Circles* drawn about the *Poles* of the *World*, and parallel to the *Equinoctial* and *Tropicks*: And the *Circle Artick* is so far distant from the *North Pole*, as the *Tropick of Cancer* is from the *Equinoctial*: And the *Antartick* is at the same distance from the *South Pole*, *Viz.* 23 Degrees, 30 Minutes, and in these two *Circles* and seated the two *Poles* of the *Ecliptick*: And between them and either *Pole*, are the two *Frigid Zones*, the two *Temperate Zones*, lying between these two *Circles*, and the *Tropicks of Cancer and Capricorn*.

C H A P. VI.

Of the SYSTEM of the WORLD.

I. Of the Ptolomaick System.

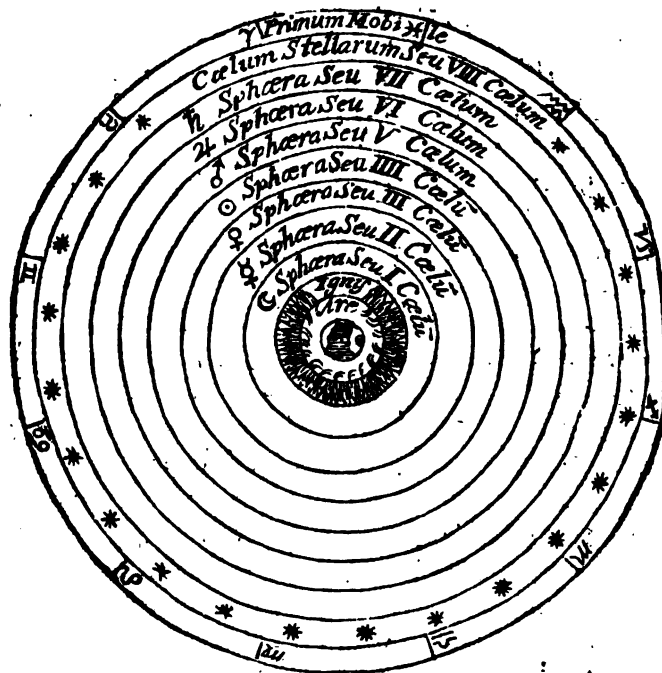

THIS System supposeth the *Earth* to be in the *Center* of the *Universe*; above it the *Elementary Region*; next above that the *Moon*, then *Mercury*; next above him *Venus*, the *Sun* as *Chief Moderator*

R E C R E A T I O N S.

rator of all the rest, in the midst of the *Planets*, environed not only by the three foregoing, called *Inferior*; but likewise by *Mars*, *Jupiter* and *Saturn*, called the *Superior Planets*; above *Saturn* is the *Sphere* of the *fixed Stars*; by some called the *Firmament*.

This was the the first *Pythagorean System*, and was embraced by *Archimides*, the *Chaldeans*, *Aristotle*, *Cicero*, *Livy*, *Ptolomy*, *Alphonsus*, *Purbacchus*; and the greatest part of *Astronomers*, until the time of *Maginus* and *Clavius*.

2. Of the Copernican System.

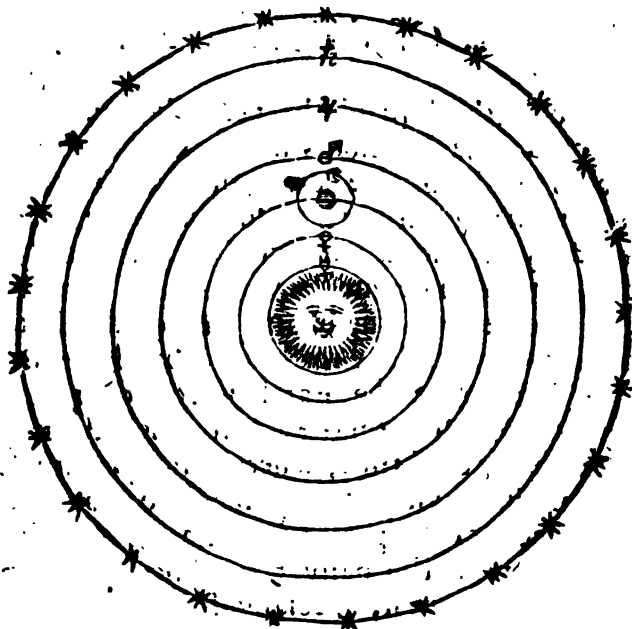

THIS System giveth to the *Earth*, not only a *Diurnal* Motion about its *Axis*, but also an *Annual* Motion about the *Sun*, as the Center of the *Universe*: This System, about two Ages since was resuscitated (but imperfectly) by *Cardinal Casanus*, until *Copernicus* came and gave it a perfect consummation, followed by the greatest Wits of this and the foregoing Ages.

In this System we may perceive the *Sun* placed in the Center of the *World*; next above him *Mercury*, finishing his Course about 80 Days: Then *Venus*, making her Revolution in *Nine Months*: Above her the *Earth*, with the *Elementary Sphere*, in the *Annual Orb*, which it runs through in 365 days and a half, by a Motion from *West* to *East*; that is, in the same Circle wherein the other System places the *Sun*; besides which Annual Motion, *Copernicus* Assigns to the *Earth* a *diurnal Revolution*, in which it turns about its own Center in the space of 24 Hours from *West* to *East*: The *Moon* by a *Menstrual* Revolution being carried about the *Earth* as in an *Epicicle*: *Mars* running about the *Sun*, (as the Center of the *Universe*;) in two years time; *Jupiter* about him in *Twelve* years; and *Saturn* in *Thirty*: The *Sphere* of the *fixed Stars*, being distant by so vast an Interval from the *Sphere* of *Saturn*, that the *Annual Orb* in which the *Earth* moves, appears in respect to it, no other than a point.

C H A P. VII.

*The Ptolomean System strongly Argued for and Maintained,
and many of the Copernican Arguments Answered by Mr.
Henry Phillippes.*

I. Of the E A R T H.

THis one would think should be perfectly known of us, since it is our natural Habitation wherein God hath placed us; but yet such is our ignorance hereof, that not only among the common sort, but there hath been much to do among the Learned, to prove that this great Body of the Earth and Water is exactly round like a Globe. And it hath been counted a very Fable, that there should be any *Antipodes* or people dwelling in any part of the Earth directly under us, supposing such would be ready to drop down from the Earth into the Heavens. But that the Earth is round, may appear by the round shadow of the Earth upon the Moon, when she is Eclipsed; and likewise by the difference of time, wherein Eclipses are seen in several places. But the most convincing Argument to prove both the roundness and habitableness of all parts of the Earth, whether we account them above, or under, is the daily Experience of our Seamen, who have and do daily Sail about it, specially from the East to the West. And though the Earth cannot be surrounded by the North and South Poles, in regard of the Cold and Ice, yet by the agreement which is found between the distance and the Latitude of places lying North and South, it is evident that the Earth is neither Flat, nor Square, nor Oval (as some have imagined) but perfectly round.

The second thing worthy consideration herein, is the Compass of the Earth. And herein there is much difference between Ancient and Modern Writers, which ariseth partly from the difference of their Measures, unknown to each other. The best Account hereof I suppose is given by Mr. *Norwood*, who for this purpose *Anno 1635*. measured the distance between *York* and *London*, and so exactly taking the Latitudes of those two places, found that one Degree in the Compass of the Earth did contain 367200 of our English Feet; so that the whole Compass of the Earth being 360 Degrees, will be 132192000 Feet, which reduced into Miles, according to the Statute, each Mile containing 5280 Feet, it yields 25036 Miles. By this you may see this Globe of Earth and Water, though it seem so great to some, that it cannot be measured, or incompassed, yet is but a small thing, considered by the Rules of Art; insomuch, that a Ship sailing one hundred Miles every day (which it may well do) it will surround this Globe in 250 days; which is less than three Quarters of a Year.

Thirdly,

Thirdly, It may be enquired, whether the Earth be the Center of the Universe or not ; and whether it stands still, or hath any Motion ?

For answer hereunto, I say, it hath been the most received, and in my Judgment the best grounded Opinion, That this Globe of Earth is the Center of the Universe, being without any Motion, and that the Sun, Moon and Stars are moved round about it : Yet it was the Opinion of *Pythagoras* and *Aristarchus* (very Ancient Philosophers) that the Sun is the Center of the Universe, and that this Globe of the Earth is turned round about the Sun, together with the Moon, and the rest of the Stars and Planets. This Theory was left off by *Ptolomy*, whom most of our following Astronomers have followed until *Copernicus*, who revived the foresaid Hypothesis, and since that he hath had many followers. And though this may seem to be a very strange Conceit, yet they bring very probable Arguments (in point of Art) to confirm it. In answer to which, I shall propound these Six Considerations.

First, That this Opinion is at the best Fortified, but with probable Arguments ; whereas for the standing still of the Earth we have daily a sensible, if not a real Experience. And though our Senses may be deceived herein ; yet it will be hard to prove that they are deceived.

Secondly, Though this Theory, in some Respects, doth yield much Harmony in the places and motions of the seven Planets, giving a good Account of their direct and retrograde Motions, without any Epicycles ; yet it fails much in the fixed Stars ; supposing them to be so far distant from the Center of the Universe, as is beyond all probability. For it is certain by the most accurate Observations of *Tycho Brahe*, and his Successor *Longomontanus*, that there is not the least observable difference in the Latitude of places observed by the fixed Stars, at any one time of the year more than other ; no not to the quantity of half a Minute. And therefore if this Theory be allowed, it must be Granted, that there is such a distance between the fixed Stars, and the Center of the World, that not only the Globe of the Earth, but that vast distance of the Sun from the Earth (which is the semidiameter of the Sun's Annual motion) must in respect thereof be but a little Point, not causing half a Minutes Parallax, or difference of appearance. Now if such a distance be allowed as is requisite for this purpose, observe how it will exceed all proportion. For whereas *Saturn*, the farthest of the Planets, by the consent of all Astronomers, is distant from the Earth but about 12000 semidiameters of the Earth, the fixed Stars according to this Account must be distant 7904818 semidiameters : So that the place between *Saturn* and the Stars is 7892818 semidiameters, which is 658 times more than *Saturn* is distant from the Center. Thus you see there is no proportion between this vast distance of the Stars above *Saturn*, and the Planets under him. Besides, all this vast distance is but Waste and Useless, there being no Stars, nor any visible Furniture therein, and God and Nature makes nothing in vain.

Again, if according to this foresaid distance you Calculate the quantity of the fixed Stars by their visible Diameters, a Star of the first Magnitude will be greater than the Sun it self 16907143 times, and their true semidiameter, or half the breadth of such a Star, will be more than 8 times the distance which is between the Sun and the Earth.

B

But

But these things are so unlikely, that it makes as much against this Hypothesis, as the other probabilities plead for it.

Thirdly, The Followers of this Opinion hold, that the Earth hath a daily motion, whereby it is turned round about upon its own Axis every day. And for this motion they bring a very plausible Argument; for by this (say they) the incredible swiftness of the Heavens and Stars is very well salved. For if according to *Tycho*, you allow the fixed Stars to be but 14000 semidiameters distant from the Earth; whereas *Ptolomy* accounts them 20000, yet the Stars near the Equator must move every Minute of an Hour 240000 Miles to perform its daily motion round about the Earth. This motion they count too swift for any natural body to perform; and therefore think it more likely that the Earth should turn about once every day, and thereby cause the rising and setting of the Sun and Stars.

This conjecture is so probable, that many who are against the Annual motion of the Sun, yet yield to this daily motion: But yet I conceive that the Earth is not subject to this motion neither: For if the Earth should according to this Opinion move every day round upon its own Axis, then we which live upon the Surface of the Earth must be moved with the Earth above 1000 Miles every Hour. Which motion, though it be very slow in respect of the foresaid swiftness of the Stars, yet considered by it self, and compared with the motion of things here below, it is exceeding swift, far surpassing the Flight of the swiftest Bird, or the Bullet from the Cannons mouth. And therefore surely if any such motion were, we should be more sensible of it, than we are.

But Grant that this motion should be performed by the Earth, and we not sensible of it, in regard of constant use unto it; as men that are used to the Sea are not troubled so much with the motion of the Ship as others are: Yet judge whether it be not more likely that the Heavens, Sun, Moon and Stars, being all Light and pure Bodies, should perform the foresaid swift motion (though to us almost incredible) than that the Earth (a dull and heavy Body) should perform this latter motion. As we see by experience, that a Horse being a Creature of a nimble fiery temper, is better able to run 20 or 30 Miles in one Hour, than a Snail which is a dull sluggish Creature to creep one Poles Length, which is scarce the ten thousandth part thereof.

Consider also, that this swift motion in the Heavens is no more to be wondred at, than the vastness of their Circumference; and it is but reasonable to think, that God who hath made them of so great Compass, hath likewise fitted them for so swift a motion. And the Truth is, swiftness of motion depends neither upon the Greatness or Smallness of the Creature, but upon the appointment of the Creator. Thus we see by experience, the little Hare exceeds for swiftness both the Sheep, a Midling, and the Oxe a Creature of the largest size; and yet is out-stripped by the Dog and Horse, Creatures likewise of the middle and larger size. So that it is neither the smaller Compass of the Earth, nor the larger Compass of the Heavens, which can either prove or disprove the daily motion of either: But herein the wonderful Power of God is the more magnified in making the Heavens, not only by their vastness to encompass the Earth, but also by their swiftness daily to surround the same.

Fourthly,

Fourthly, Though this Theory in some things may be more plainly demonstrated by Geometry than the Theory of *Ptolomy*, being freed from those Epicycles; yet this may also be performed by the Hypothesis of *Tycho*; and the places and Aspects of the Planets may be as truly and readily Calculated thereby, as by this. Experience we had hereof in that great Eclipse of the Sun the 29 of *March* 1652, about which most of our Writers following new Tables, according to this Hypothesis, were greatly mistaken in the time of the Eclipse, reckoning it half an hour too soon: Whereas I calculating it by the Tables of *Tycho*, and *Longomontanus*, it fell out very exactly. And you shall find, that in all the Eclipses observed by *Tycho* and *Longomontanus*, their Tables never failed them so much. And for the motions of the Sun and Moon, there are none like them: So that you see there is no necessity of following this strange Hypothesis.

Fifthly, This Opinion is against the constant Tenor and ordinary Phrase of the Holy Scriptures, which ought to be had in special Reverence; and from which we ought to be very careful how we vary in any thing, pretending the Scripture speaks herein, according to the sense and apprehension of common people, especially when the thing pleaded for is so unlikely and unnecessary.

Lastly, This Opinion is of dangerous consequence, the followers thereof being subject to fall into many vain curiosities, and Fruitless Errors: As that the Moon, and the rest of the Planets and Stars, may be each of them habitable places, as well as the Earth; and some have Written largely to prove, that there is a World in the Moon, and that our Earth gives light unto them, as the Moon doth unto us; and so Account the Earth to be as one and the same kind with the Stars and Planets; whereas it is plain in *Gen. 1.* that God made the Earth on the third day of the Creation, and furnished it with all sorts of Herbs and Trees; but the Sun, Moon, and Stars were not made until the fourth day: Which is enough to prove them Creatures of a different kind and nature; and we cannot find the least hint that God made the Moon, &c. for an habitable place, or the Earth to give Light to the Heavens; but *Ver. 14, 15.* it is plainly expressed, that *God said, Let there be Light in the Firmament of Heaven, to separate the Day from the Night. And let them be for Lights in the Firmament of Heaven, to give Light upon the Earth; and it was so.* There is not a syllable of the Earths mutual and reciprocal Light.

To conclude this particular, most of you I suppose are ready enough to think, that these Men err very much in making the Heavenly Bodies to be Earthly Habitations; yet give me leave to tell you, that there is a more common and dangerous Errour, which we had all need to take heed of; and that is, that we do not account this Earthly Dunghil to be our Heavenly Habitation, by laying out all our Care and Pains upon it: But whilst we live upon the Earth, let our Conversations be in Heaven, from whence we look for a Saviour, the Lord Jesus Christ. And now leaving the *Earth*, it is time to ascend to the other Orbs, *Viz.* That of the *Moon, Mercury, Venus, the Sun, Mars, Jupiter, Saturn, the fixed Stars, the Christaline, and first moving Heavens.*

2. Of the Moon.

It is time for me now to leave the Earth at rest in the Center, and to speak of the Heavenly Bodies and their Motions. And the Moon in the first place presents her self, being by the consent of all Astronomers placed next the Earth.

First, for the Form or fashion of the Moon, it is round every way like a Globe. And this may be proved by the successive and proportional Light which it receives from the Sun; for if it were round and flat like a Trencher; then the Light of the Sun coming to the flat side would presently spread all over it, as it doth upon the flat side of an House or upright Wall.

Secondly, As for the matter of the Moon, or what substance it is made of. Those that hold the motion of the Earth, they think the Moon to be very little different from the Earth, having Sea and Land, Mountains and Valleys: And this they gather from the spots which are seen in the Moon, accounting those darker places to be Sea, and the brighter places to be Land. But I conceive the Moon to be of some like substance with the Clouds: For if you look upon the Moon in the day time, you shall see many times in a fair day, when the Clouds are High and White, that the Moon and they are all of one Colour. Again look upon the Clouds in such an Evening about Sun-setting, and you shall perceive the Clouds to reflect the Light of the Sun, and to shine as the Moon doth: And this Light thus reflected from the Clouds and the Vapours of these lower Regions, is the Cause of the Twilight, which continueth till the Sun is 18 Deg. under the *Horizon*, and then the shadow of the Earth falling upon the Clouds, doth take away their shining, just as the Moon loseth her Light in her Eclipse, which proceeds from the same Cause. Add to this the many Resemblances of many Suns and Moons, which are divers times seen in the Air, which are nothing else but Clouds fitly formed and placed to Reflect the Light of the Sun unto us. All this may shew, that the Moons substance doth in some sort resemble that of the Clouds. And as for the duration of the Moon, longer than the Clouds, this it hath by Gods appointment, who also caused that Cloud to Guide the *Israelites* 40 years in the Wilderness, which was a Pillar of Cloud by Day, and a Pillar of Fire by Night.

Thirdly, It is a common question; whether the Moon have any Light of her own? or whether she receive all her Light from the Sun?

For answer hereunto, consider that there are several sorts of Lights; first there are some things that have not only Light in themselves but give Light to other things, as the Fire and the Sun. Secondly, there are some things that have no great Light in themselves, yet they shine in the Dark; as Glow-worms, Rotten-wood, and Fish-Skins. Thirdly, there are some things which may be said to have Light, but this Light appears best in a greater Light; as white things, polished Metals, Glasses and the Clouds. And such a Light I conceive the Moon hath of her own, whereby she is fitted to Reflect the Light of the Sun to our Sight. Yet I do not think, as some have supposed, that the Moon is so perfect a mirror as that the spots which we see in the
Moon

Moon are nothing else but the Image of our Earth and Sea which we see therein; as when we look upon a Glass we behold our own Image therein: Much less do I believe what some have said, that things done, or a Writing set before the shining Moon, may be seen and read in the Moon at an other place of the World, very far distant from it; as by the Reflection of Glasses it may be performed for a small distance.

Fourthly, If you demand what may be the Reason of those spots which are seen in the Moon? I answer, they proceed from the roughness and inequality of the Moons Body. For though the Moon hath not Hills and Dales, Mountains and Valleys; yet as you see the Clouds are many of them ragged things, and not smooth and plain; so it may very well be in the Moon, though in regard of her distance they are not so discernable. And this supposition will very well agree with all the Observations of these spots, both in the New and Full Moon. For first, in the New Moon, by Reason of this inequality of the Moons body, some little spots of Light will appear before the main body of Light, on the tops of these rough places, and then again towards the Full Moon, this inequality will cause much difference in the Light of the Moon: Just as you see when the Sun shines full upon a Glass Window, though the Window be in a manner flat, yet if the panes of Glass lie never so little slanting, it will cause a difference in the Reflection, and one place will seem darker than another.

Fifthly, As for the quantity of the Moons body, and her distance from the Earth: How these things come to be known, I shall shew hereafter: In the mean time, it shall suffice to tell you, that according to *Tycho*, the Moon is distant from the Earth 56 semidiameters of the Earth, which reduced into English Miles, is 233048 Miles: And though the Moon appears so little to us in regard of this distance, yet the true Diameter or Breadth of the Moon is 2060 Miles, and the Compass of it 6474 Miles; so that the Breadth and Compass of the Moon is a little more than the one quarter of the Breadth and Compass of the Earth; and if you regard their solid Proportions, the Earth is 50 times bigger than the Moon.

Lastly, The Moon hath a four-fold motion: The first is its daily motion, wherewith it encompasseth the Earth in 24 Hours 48 Minutes. The second is her motion in the Zodiack, wherein she is the swiftest of all the Planets, running through all the Twelve Signs in 27 Days, 7 Hours, 43 Minutes. Thirdly, she hath her motions from the Sun, whereby is caused the diversity of her appearance; this motion is finished in 29 Days, 12 Hours, 44 Minutes. Fourthly, she hath a motion of Latitude from the Ecliptick Line, or way of the Sun, which is the Reason that there are not Eclipses every New Moon and Full Moon; and this motion is finished in 18 Years, 7 Months, and 12 Days. Many good Uses might be made of these motions; but of these I have, and shall speak more in its time.

3. Of Mercury and Venus.

I put these two Planets both together, for though they have some difference in their motions, yet in some respect they are both alike: These as two diligent Pages, continually wait upon the Sun their Lord, being never far distant from him.

As for their order in the Heavens, *Ptolomy* placeth *Mercury* next above the Moon, and *Venus* next above him, both under the Sun. But here in *Tycho* in some sort agrees with *Copernicus*, and the later Astronomers all consent therein, making the Sun the Center of the Planets, and so they place *Mercury* next the Sun, and *Venus* a little further off the Sun; supposing them to turn round about the Sun, as it were in two little Circles; so that either of these Planets, are sometimes above, and sometimes under the Sun: And sometimes *Venus* may be nearer to the Earth than *Mercury*.

Hereby also you may perceive the cause why these two Planets are never very far distant from the Sun, for they can go no farther than their Circles will give them scope: which for *Mercury* is about 29 degrees; and for *Venus* about 48 degrees.

Mercury, by reason of his continual nearness to the Sun, and the smallness of his body, is seldom seen. But *Venus* by her Lustre is known unto all men; she sometimes runs before the Sun, and then she is called the Morning Star, sometimes she follows the Sun, and then she is called the Evening Star. And so great is her brightness (by reason of her nearness to the Earth) that she is not only seen in the Night, but many times in the Day, which many will gaze at; but the Learned and Diligent *Tycho* made a very good use of it: For by observing the distance between the Sun and *Venus* in the Day time, and then the Night following observing the distance from *Venus*, to some of the fixed Stars, and from them to others; he thereby found out their places more exactly than by any way else he could attain to. But if such an Eclipse had happened in his time as that of the 29th of *March* 1652, or that *August* 9. 1654. both which happened about High-noon, wherein some of the fixed Stars were seen, he might have performed this conclusion with more ease and certainty. And I hope some lover of Astronomy or other, hath made such use of this occasion, which would be of great concernment, either for the rectifying or confirming of former Observations, in this so necessary a part of Astronomy, And I hope if all have neglected it this time, that some will be diligent in it, at the next great Eclipse of the Sun.

The distance of these two Planets from the Earth, is somewhat different, but according to their middle distance they are accounted to be removed from the Earth, as the Sun is, of which you shall have more in the next Section. The breadth and compass of their bodies is thus:

Breadth of	}	<i>Venus</i>	4397	}	Miles.
	}	<i>Mercury</i>	2931	}	

Compass

Compass of $\left. \begin{array}{l} \text{Venus } 13800 \\ \text{Mercury } 9354 \end{array} \right\} \text{ Miles.}$

4. *Of the Sun.*

The Sun is the principal and chiefest of all the Planets and Stars, being the Fountain of all the Light we receive; and therefore is most fitly placed in the midst of the Heavens. As for the matter of it, it cannot be no other than pure Fire, as is manifest by the effects thereof, Light and Heat: For though Heat may be without Lustre in some things, and Lustre without Heat in many other things, yet Heat and Lustre both cannot be without Fire: But this Fire I speak of, you must not imagine to be any gross Fire, but pure Elementary Fire, which needs not the continual supply of Fuel, but of it self is lasting and durable. For though the Psalmist saith, *Psal. 102. 26. that the Heavens shall wax old as a Garment*, this is rather by the Sin of Man than by their own Nature.

This Sun, as it is the most glorious, so it is the most useful Creature of all others, being not only the Fountain of Light, but the Fountain of Life unto all Creatures; this made the Heathen Worship him for a God; and the Jews, though better Instructed, and expressly forbidden, could scarce refrain from this Idolatry, but Worshipped the Sun and Moon. Let us take heed of this, but let us praise God for them, and with them, who made both us and them, as we are exhorted, *Psal. 148. Praise him Sun and Moon, praise him all ye Stars of Light; for he commanded, and they were created.*

As for the motion of the Sun; First, It hath a daily motion round about the Earth, by which it makes the Day and Night. Secondly, It hath a Yearly motion round about the Heavens; whereby it causeth Summer and Winter, Spring time and Harvest: This course it finisheth in 365 Days 5 Hours, 49 Minutes, which odd 5 Hours 49 Minutes, in 4 Years makes up almost one whole Day, and is therefore added every fourth Year or Leap-year; for otherwise, in a little time the Month of *June* would fall in the *Winter*, and *December* in the *Summer*, as it did in the *Egyptian* year. But this was thus rectified by *Julius Caesar*, which account, though it was far more exact than any of the former; yet by reason that those odd hours and minutes did lack 44 minutes of one day in those 4 years, it hath caused some alteration in the year since his time. For whereas the Sun in his time entred into *Aries* on the 25th of *March*, it now enters into *Aries* about the 10th of *March*; and hereupon Pope *Gregory Anno 1582*, caused ten days to be cut off from the old Account, and this is the reason the Account beyond Sea is ten days before ours, which makes their *Easter*, and all their Movable Feasts, fall most times before ours.

The distance of the Sun from the Earth, according to *Tycho*, is 1150 Semidiameters of the Earth, which reduced into Miles, is 4580450 Miles. The diameter or breadth of the Sun's body is 42600 Miles; and the compass thereof is 133886 Miles; so that the compass of the Sun is above 5 times the compass of the Earth: But if you have regard

to the solid contents thereof, then the Sun by this Account is 153 times bigger than the Earth.

As for the daily compass which the Sun runs in the Heavens, it is 28789124 miles; so that every hour it runs 1199547 miles, which is every minute near upon 20000 miles. And yet to perform so swift and continual a motion, the Sun needs neither the Poetical Fiction of Horses to draw it, nor the more probable Opinion of the Earths daily motion to ease it of its labour; but by the appointment of God, cometh forth as a Bridegroom out of his chamber, and rejoiceth as a mighty man to run his race: his going forth is from the ends of the Heavens, and his compass to the ends of the same, Psal. 19. 5, 6.

5. Of the Three Superiour Planets, Saturn, Jupiter and Mars.

These three Planets are accounted by all Astronomers to be farther from the Earth than the Sun. As for the motions of these Planets, tho their daily motions are swifter than the other Planets, being farther distant from the Earth, yet their periodical motions are more slow; and according to their distance from the Earth, so is their slowness. For Mars, the nearest of these three, finisheth his course in one year 322 days. Jupiter the next, in 11 years 318 days. Saturn, the farthest, in 29 years 174 days; in these times they run thorow the 12 Signs in their Ecliptick.

Besides these motions, there is also a retrograde motion, which not only those three, but Venus and Mercury are subject to. Indeed, the Sun is exempted from it (as it were by extraordinary priviledge) and the Moon avoids it by her swift motion; but Mercury and Venus, tho in their mean motion equal to the Sun, yet are often driven backward.

Mercury is the most often subject hereunto of all the Planets, being very inconstant in his motion; running over this motion every 116 days, being direct 92 days, and then retrograde 24 days. Saturn is more constant and serious in his walk, renewing this motion once in 378 days, being direct 238 days, and retrograde 140 days. And Jupiter, his next Neighbor, as it it were to keep him company, walks this round in 399 days, going forward 279 days, and then backward 120 days. But Warlike Mars, as scorning to turn his back, marches on furiously for 700 days together, yet then he is forced to counter-march as fast for 80 days. Lastly, Dame Venus, proud of her Beauty, which she is loth to have too long hidden, or fears will be too much burned by the Sun, runs as fast as she can before him for 542 days; but when she sees the Sun will over-take her, she turns about and runs the contrary way for 42 days, that so the Sun may the sooner overshoot her, and she may again shew to the Earth her glorious Lustre. These motions you may evidently see in these Planets, if you observe their situation Nightly in respect of the fixed Stars; but the farther ground and demonstration hereof, I have not time to speak of.

Lastly, For the distance of these three Planets from the Earth, Mars is distant 1745 Semidiameters, Jupiter 3990, Saturn 10550, which being granted, their distance, breadth, and compass in Miles, is thus:

Distance.

	<i>Distance.</i>	<i>Breadth.</i>	<i>Compass.</i>
<i>Mars</i>	6950535	3336	10484
<i>Jupiter</i>	15892170	12800	40228
<i>Saturn</i>	42020650	21920	68891

6. *Of the Fixed Stars.*

I call these *Stars* fixed, not because they are void of all motion, but because they keep their places very exactly one in respect of another. Infomuch, that those *Stars* which were to be observed in a right line by *Hipparchus* 1700 years ago, were found so by *Ptolomy* in his time 1300 years ago, and continue in the same posture still, as you may see by many Examples in *Tycho*, lib. 1. p. 134. Therefore it is very probable that they all are fixed in one Sphere, and are all equally distant from the Earth, since they are so uniform in their motions.

The motions of these *Stars* are two: The one daily from East to West, the other yearly according to the order of the Signs. In their daily motion they are exceeding swift; for the compass of their *Heaven* is above 350000000 of Miles; so that those *Stars* which are towards the Equator, must move 24000 Miles every minute of an hour. But in their other motion they are exceeding slow, not moving one whole minute in a year, but only one degree in 70 years; so that they will be 25000 years in making their progress through the 12 Signs. This motion by the Ancient Astronomers was thought to be finished in 36000 years, and is called by some the *Platonick year*: At which time, according to their Opinion, all the *Stars* having finished their Revolutions, shall return unto their first places; and that all other things shall return with them again to the same order wherein they were. But this Opinion is very vain, for neither will the motions of the Planets and *Stars*, calculated together, agree to such a Revolution: And the Apostle *Peter* affirms, *That both the heavens and the earth which now are, shall be destroyed with fire, at the last day*, 2 Pet. 3. 7. which will certainly be long before this Period.

Concerning the number of the *Stars*, though it be great, yet it is not infinite. Astronomers take notice only of about 1000, which are the most conspicuous, and though sometimes in a clear Winter Night many more little ones may be perceived, yet they cannot certainly be observed; and those aforesaid seem many more than they are.

The Ancient Astronomers, the better to distinguish and describe these *Stars*, have drawn them upon their Globes and Maps in 48 Images; so that every *Star* comes to have a Name from that part of the Image they are placed in: As the *Bulls Eye*, the *Lions Heart*, and such like. Some Modern Astronomers have added 12 Constellations more towards the South Pole, which were not known to the Ancients.

ASTRONOMICAL

Another way whereby these Stars are distinguished, is by their several bignesses, and to this purpose they rank them into 6 Magnitudes. This distinction is far more apparent than the other, the Constellations being only Poetical and Imaginary, this difference real and visible. But though the biggest of these Stars seem little in regard of their great distance from us, yet are they of wonderful greatness. For if you reckon only their distance according to *Tycho*, to be 14000 semidiameters of the Earth (whereas *Ptolomy* allows 20000) this reduced into Miles, yields 55762000. Which being supposed, their Breadth and Compass, according to their visible Diameters, will be as followeth.

	Breadth	Compass	Number
1	32342	101643	15
2	24256	76232	45
3	16843	52935	208
4	12128	38116	474
5	08085	25410	217
6	05090	16941	49

Hereby you see, that the smallest Stars are almost as big as the Earth, the Compass of the Earth being 25036 Miles, as we shewed before. The next sort are full as big, or bigger, and all the rest in Order, far exceed the Earth. So that a Star of the first Order is four times the Breadth and Compass of the Earth; which Cubically considered, renders the Stars 65 times greater than the Earth. Thus the least things in Heaven are great, though they seem small, and the greatest things on Earth are small, though they seem great. Let this teach us to esteem of things, not as they seem, but as they are.

7. Of the Crystalline Heaven.

This is fitly called the Watery Heaven, whose place is above the Stars: For though no such thing is apparent to our Eyes, yet the Scriptures make frequent mention of it. This was the Work of the second Day in the Creation, *Gen. 1.6,7. Again, God said, Let there be a Firmament in the midst of the Waters, and let it divide the Waters from the Waters. Then God made the Firmament, and separated the Waters which were under the Firmament, from the Waters which were above the Firmament.* This, though some interpret of the Waters in the Clouds, yet it cannot be so meant, for the Clouds are far below the Firmament, those Waters are above it; Besides, the Clouds are but Vapors arising daily out of the Earth. And though this may seem strange to Sense or Reason, yet it is the best way in this Point to Resolve with *Dr Bartas*,

*I'll rather give a thousand times the Lye
To mine own Reason, than but once deny
The Sacred Voice of that Non-Erring Spirit,
Which doth so plainly and so oft aver it,*

That

*That God above the Highest Firmament,
I wot not, I, what kind of Waters Pent.*

Pfal. 104. 3. Pfal. 148. 4.

And the better to perswade you to this, consider what he saith afterwards;

*I see not why Mans Reason should withstand,
Or not believe, that God, whose Powerful Hand
Bay'd up the Red Sea with a double Wall,
That Israel's Host might 'scape Egyptian Thrall:
Could prop as sure these Waters thus on High,
Above the Heavens Starry Canopy.*

And here, by the way, let those who plead for the motion of the Earth, and the standing still of the Sun, contrary to the constant Phrase of the Holy Scriptures, see what Force is in their excuse, as if the Scriptures in these things, spake only according to our Common Sense, and the Vulgar Opinion; and not the real Truth, according to Nature and Art, to inform our Judgments. I am sure in this Point the Scripture speaks a Truth, which passeth both the Sense and Art of Man to apprehend. And not only in this one particular, but many other things, there are set down in the Creation, which are above, though not contrary to the Rules of Philosophy: As that there should be day, three days before the Sun. That the Trees and Plants should spring and grow without the Sun, which is the natural Cause of their Production. That the Bird should be before the Egg, which is preposterous in natural Generation: Yet these things we ought to believe, much more such things as are more conformable to our sense and common Experience.

What may be the use of these Waters, is very difficult to determine, the Scriptures herein being silent. Some think they were partly used for the downing of the Old World: For it cannot be made good that so much Water could probably descend from the Clouds, the Waters being above the highest Mountain, and many of these Mountains being higher than the Clouds themselves. Neither is this Phrase used to set forth the Rain that comes from the Clouds.

Others think that those Waters are placed here, for the cooling of the Firmament, which else would be set on Fire by its swift and continual motion; and that the daily Consumption of these Waters, will be a secondary Cause of the Burning of the Heavens and the Earth at the last day. But these things are uncertain. The best use of them is set forth by the Prophet, Psal. 148. 4. *Praise the Lord ye Heavens of Heavens, and ye Waters which are above the Heavens.*

8. Of the first moving Heaven.

Above all these (by the Opinion of many) there is a great vast Sphere incompassing all the rest, which is called the *First-moving Heaven*; this is supposed to move round every 24 Hours, and therewith to carry round about all the Stars and Planets every day. But as this is above our senses to perceive it, so the Reasons they bring to prove

it, are not of sufficient Force. And I rather think that God hath indowed these Cœlestial Bodies with an inward Power to perform their several motions. For though they are not living Creatures, as some have imagined; yet they may have a Propensity to move to a certain Point, or in a Circular motion; as we see the Load-stone doth, being fitly placed.

For suppose those Heavens, or Heavenly Bodies had need of any outward Cause of their motions: Yet how can this *Primum Mobile* yield them any help therein. For though it might move the highest Firmament wherein the Stars are, and which keep a Uniform motion among themselves; yet how can it move the Planets which are farther from it, and have so many several motions? They answer to this, that the diversity of their motion proceeds from their distance from this First Mover, which thereby hath the less Force over them, to hinder them in their proper Motions from the West to the East. But to this it may be replied, that if they have a Power of themselves to perform the one motion, why can they not perform the other daily motion likewise by their own Power.

The Resolution of these motions might much better depend upon the daily motion of the Earth upon its own Axis; and did not the Scriptures so oppose this motion, I should willingly assent thereunto. But I shall find this one Argument more against this Opinion of the *Copernicans*. For they supposing the earth to be a Planet, how then can they think that the Earth should have any other motion than the rest of the Planets? Now that the other Planets have no such diurnal motions upon their own Axis, is apparent by the Moon; which if she had any such motion, the spots in the Moon would not appear always in the same place of the Moon as they do, both on the East and West of the Meridian: For if the Moon were turned round, these spots would be sometimes on the one side, and by and by on the other. But if you observe these spots, you shall find the Picture of the Man in the Moon, continually on the Western side of the Moon, and though some variation it may have in respect of the vertical Point, yet in respect of the Pole of the *Ecliptick*, it keeps the same place very exactly, just as the Horns of the Moon do in the ~~same~~ and later part of the Moon.

Thus I have ascended to the Highest Parts of the Visible Heavens, and have (I hope) in some Measure performed my Promise.

C H A P. VIII.

Containing some of the strongest Arguments (by way of Objection) the Maintainers of the Ptolomean System bring against the Copernican System: With the Answers the Capernicans give unto them. Extracted out of the Writings of Pythagoras, Galileus and other later Astronomers.

O B J E C T I O N I.

THeir First Objection is against the Motion of the Earth: For (say they) *We see the Sun, Moon and Stars Rise in the East, and make a Progress by the South, and set in the West: And therefore our Visual Sense Demonstrates, that they move, and not We.*

A N S W E R.

In Answer to this, it may be urged; That the Sense of seeing is deceitful, and makes that seem to move which stands still, and that stand still which moves; as is often seen upon the Water. For, Rowing in a Boat, the Boat shall seem to lie still in the Water, and the Banks of the shore shall seem to slide away from us: And many times the Moon and Stars shall seem to go along with us, which way soever we go.

O B J E C T I O N II.

If we stand upon a Hill (or on the Top of a main Mast of a Ship at Sea) then Looking round about us, the Heavens appear on each Quarter exactly Equidistant from us: Therefore the Earth is in the Center of all the Heavens: For, were it in any other Place, we should perceive one part of the Heavens nearer to us than another; and the Stars would shew Greater on that part of the Heaven, which shews near to us, and less to that part of Heaven which shews farthest from us.

A N S W E R.

The Distance of the *Starry Heaven* from the *Sun* (which is the Center of the *Starry Heaven*) is so vast, and the distance of the *Earths Orb* so small, that it seems in the very Center it self, and therefore makes

ASTRONOMICAL

makes in the *Sight* no Alteration; as by this following *Scheme* and *Example*, may be easily conceived: Wherein imagine this Circle, representing the *Starry Heaven*, to be 20 Inches Diameter: A is the Center of the Circle, which is, in all parts, equidistant from the *Circumference*. This Line AB will then be 10 Inches. Now suppose the Line AB were divided into 6875 equal parts (for the *semidiameter* of the *Starry Heaven*, contains the *semidiameter* of the *Earths Orb* 6875 times) and that the Center were removed from its true place at A, one of those equal Parts: Then may you, first, consider the apparent Length of one of those Parts; and secondly, what difference, in

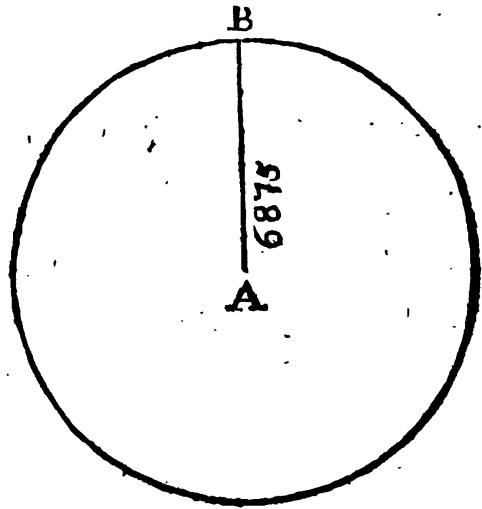

appearance from the Center, it would have: If then the whole Length AB 10 Inches, be divided into 6875 equal Parts, then shall every Inch be divided into 6875 Parts, which is so small, that it exceeds not half the Breadth of a Hair of ones Head: And what difference, at the *Circumference*, half a Hair Breadth will make from the true Center of a Circle of 20 Inches Diameter, is to be considered. It is true, it is a difference from the true Center, but so small, that no Man with the Point of a Needle can make a perceptible *Mark* of that Size. Now, though the distance of the *Earths Orb*, from the Center of the *Starry Heaven*, be so small that it is scarce discernable, by Reason of the vast distance of the *Starry Heaven*, yet the distance of the *Earths Orb* from the Orbs of *Mars* and *Venus* is not so great, but that a sensible difference appears at several times in the light of these *Planets*: For *Mars* in his *Perigeum* (or when he is nearest to the *Earth*) appears 60 times bigger than in his *Apogeeum* (or when he is at his greatest distance from the *Earth*) and *Venus* in her *Perigeum*, appears 40 times bigger than in her *Apogeeum*: As (with good *Telescopes*) hath been Observed by *Galileus* and others since.

OBJECTION III.

It is against Reason (say they) to think the Earth should turn round; for then, we should, every Conversion have our Feet turned upwards, and our Heads hanging downwards in the Air: Our Houses would tumble over; and every loose thing, as Stones, Animals, &c. Fall from the Earth, at having nothing to rest their Weight upon.

ANSWER.

It is unreasonable to think *Nature* should create any thing to its own Destruction; which we must allow, in case the Place Assigned it by *Nature* be not quite enough to retain it; for nothing can subsist without

without a proper *Place*: But we see it customary with *Nature* to Act beyond *Vulgar Reason*: For, whither the *Earth* turn *Round*, or stand fix'd in the *Center*, it matters not in this *Argument*: For, we all allow the *Earth* to be *Round*, and few Men now are so unskilful in its *Shape* or *Figure*, as with *Lactantius*, to deny an *Antipodes* to every *Place* on the *Earth* and *Sea*. Which *Antipodes*, according to his *Argument*, is as much subject to these *Casualties*, as the whole *Earth* in its *Conversion*: Nay, the whole *Earth*, by admitting *Antipodes*, run equal hazard of dropping all loose things into the *Air*, as admitting of the *Earths* *Conversion* does.

O B J E C T I O N I V.

If according to the *Copernican Doctrine*, the *Earth* move round from *West* to *East* in 24 *Hours*, then (admitting the *Circumference* thereof to be 21600 *Miles*) it must in one *Hour* move 900 *Miles*, and in a *Minute* 15 *Miles*, and in the fifth Part of a *Minute* 3 *Miles*. So that if a *Stone* be let fall from an *High Steeple*, and it be the fifth part of a *Minute* in falling, by that time the *Stone* comes to the *Ground*, the *Earth* should have passed from *West* to *East* three *Miles*, and the *Stone* must (by consequence) fall three *Miles* to the *Westward* of the *Bottom* of the *Steeple*. And to this *Objection* may be added another; *Viz.* That *Pigeons* may by strength of their *Wings* fly three *Miles* to the *Westward* from their *Dove-House* in one quarter of an *Hour*: But in this time should the *Dove-House*, by the *Earths* motion be receded *Eastward* 225 *Miles*. which with the acquired motion of 3 *Miles*, makes 228 *Miles*, and then they should alight 228 *Miles* off from their *Dove-House*: Both these *Arguments*, and several other of the same *Nature*, experience contradicts; and therefore the *Earth* stands still.

A N S W E R.

By the *Earth*, is not meant only this bare *Ball* of *Earth* and *Water* whereon we dwell; but the whole *Body* as it is *Cloathed* with the *Elements* of *Air* and *Fire*: For these *Elements* are frequently convertible into each other: And as *Philosophers* teach us, are never so purely one, as not to have a mixture of all: Therefore, whatsoever is within this *Sphere* of *Elements*, we say is in the *Earth*, though part of these *Elements*, for their *Purity*, be *Elevated* above the *Surface* of that solid *Body* of *Earth* wherein we go: And therefore when we say the *Earth* moves, we do not mean only that part of the *Elementary Sphere* which we call *Earth*; but by the *Earth* we mean the whole *Body* of *Elements*; which is according to this *Doctrine* agitated by one single *Activity*; and what ever moves in any part of this *Sphere*, moves in all: As for Example, The *Stone* and the *Doves* being *Elementary Bodies*, are inclosed within the *Sphere* of the *Earths* *Activity*; *Viz.* Within the *Air* of the *Highest*, and therefore have the *Motion* impress'd upon them that the *Earth* hath: For which way soever the *Stone* falls,
or

or is thrown; or which way soever the Pigeon Flies, they move along Eastwards with the Earth, though they fly Westwards. Thus Experience shews, That if a Ship Sails with a swift motion Westwards, it may in one second of Time run about 9 Foot; and if one let fall a Stone from on high into the Hold, that Stone shall not fall 9 Foot Eastwards from the Perpendicular Point, but just upon the same Point in the Bottom of the Hold it would have fallen, if the Ship had lain still, *Viz.* on the Point Perpendicular to the Point above it, from whence it was let fall; whereas, if the Stone had not received the Imprest motion of the Ship, it must have fallen 9 Foot to the Eastward of that Point.

O B J E C T I O N. V.

The Earth is a Heavy Body, and therefore unfit for Motion, especially through the pure Heavens; for such is the sublimity of them, that the Weight of the Earth would press through them, and so it should lose its Place.

A N S W E R.

If the Earth be a Heavy Body, yet it is not unfit for Motion, if the moving Power be strong enough to set it going: But Heavy Bodies are more unfit to lie still in the sublime Heavens, than to move in them: For thus we shall see, a Stone thrown into the Air, whilst it hath Motion it will abide there, but when the motion dies, the Stone falls.

These are such Objections as are Vulgarly made against this Opinion. There are others, which by some, may seem of more weighty Concern, as being against Sense, Reason, Experiment and Demonstration. Now such as desire farther satisfaction in these particulars, may Read Copernicus himself, Kepler, Bullialdus, Lansbergius, Gallileus, Helvetius, &c. There are others also that condemn this Hypothesis as Heretical (as formerly that of the Antipodes was) and discontentanions to several Places of Scripture; for they alledge. 1. That Text in Psalm. 104. 5. *He set the Earth upon her Foundations, so that it shall never move.* And, 2. Psal. 24. 2. *He hath founded it upon the Seas, and established it upon the Floods;* and several other Texts. And for the Motion of the Sun, they alledge; 3. Ecclesiast. 1. 5. *Were it is Written, The Sun ariseth, and the Sun goeth down, and hasteth to his Place where he arose,* Also, 4. Psal. 19: 5, 6. *Where the Psalmist speaking of the Sun, he saith, Which is as a Bridegroom coming out of his Chamber, and Rejoyceth as a strong Man to Run his Race. His going forth is from the end of the Heavens, and his Circuit unto the ends of it; and there is nothing hid from the Heat of it:* But in Answer to these Texts, or any other quoted in the Sacred Volume, take this pithy Answer of St. Augustine, who saith, *If any one shall object the Authority of Sacred Writ, against clear and manifest Reason; he that doth so, knows not what he undertakes; for he Objects against the Truth, not the Sense of the Scripture, which is beyond his Comprehension. Not what is in it, but what finding it in himself he fancied to be in it.*

Now

ASTRONOMICAL.

Now to conclude this Discourse ; for those that desire to make farther Scrutiny into this *Hypothesis*, I would have them to Read (besides the above named *Authors*) Dr. *John Wilkins*, late Lord Bishop of *Chester*, his Learned *Discourse* concerning a New PLANET, tending to prove, that 'tis probable our EARTH is out of the PLANETS ; Whertin he insists upon these following Particulars ; *Viz.*

I. That the seeming Novelty and Singularity of this Opinion, can be no sufficient Reason to prove it Erroneous.

II. That the Places in Scripture which seem to intimate the Diurnal Motion of the Sun, or Heavens, are fairly capable of another Interpretation.

III. That the Holy Ghost in many places of Scripture, does plainly conform his Expressions to the Error of our Conceits ; and does not speak of sundry things as they are in themselves, but as they appear unto us.

IV. That divers Learned Men have fallen into great Absurdities, whilst they have looked for the Grounds of Philosophy from the Words of Scripture.

V. That the Words of Scripture, in their Proper and strict Constructions, do not any where affirm the Immobility of the Earth.

VI. That there is not any Argument from the Words of Scripture, Principles of Nature, or Observations in Astronomy, which can sufficiently evidence the Earth to be in the Center of the Universe.

VII. 'Tis probable that the Sun is in the Center of the World.

VIII. That there is not any sufficient Reason to prove the Earth incapable of those Motions which *Copernicus* ascribes unto it.

IX. That it is more probable the Earth does move, than the Heavens.

X. That this Hypothesis is exactly agreeable to common Appearances.

C H A P. IX.

Of the Eclipses of the SUN and MOON, the causes of them, and how and when they happen.

I. *Of the Eclipse of the SUN.*

THE Eclipse of the Sun is nothing else but the direct Interposition of the body of the Moon between our sight and the Sun, for the Moon being a dense, solid, and opacious Body, and not transparent, coming betwixt the Sun and the Earth, (which is always in a conjunction) doth thereby hide more or less of the Suns bright shining Body from our sight; but yet the Sun is not Eclipsed in every conjunction, but when it falleth in, or near to the Head or Tail of the Dragon. And it may sometimes so fall out, that the Sun may suffer two Total and Central Eclipses in the space of 6 months, one of which happening before the Suns Apogæon, and the other after, in which case there may happen no Full Moon Eclipsed that Year, according to the Rule: *Fieri potest ut duo interlunia nodis proximâ & ferè centralia unius semestris intervallo accidant; unum quidem ante solis Apogæum, alterum post illud; quo casu intra totum annum lunarem nullum contingat plenilunium Eclipticum.* But it cannot be Universal (as the Moons Eclipse is) but may appear in one Climate a great Eclipse, in another it may be lesser, and in other some no Eclipse at all, and that at the self same Instant, because the Eclipse of the Sun dependeth principally on the Parallax of the Moon, which is different in every Climate, (as hereafter, God willing, in another Work) and seeing that the Sun far exceedeth the Earth in bigness, and the Earth far exceedeth the Moon, therefore the Cone of the Earths shadow cannot take away, or hide the whole body of the Sun from all parts of the Earth; but one part only shall observe the same to be total, or of the like quantity. Hence it may appear that the Sun loseth no Light, but only we are deprived of the same by the interposition of the Moons Terreneal Body, (as is said before) and therefore Astronomers define, that it is *Interceptio luminis solaris profecta ex interpositu Luna inter solem atque aspectum nostrum.* So that Suidas well observes, *That solis Eclipsis fit, quando Luna in ipsum incurrit;* and for the better understanding of what is said, behold this Figure following.

A Type

A Type of the Sun's Eclipse according to Ptolomy.

By this Type it appears, that to him that stands in C, the whole body of the Sun is hidden from his sight; to him that stands in B, half the Sun is only hidden; but to him that dwelleth in A, there is no part of the Sun hid from his sight. Now there are some that think, that in the space of 19 years all the Lunations and Eclipses return again to their old course, and happen the same again: And of this Opinion is *Pliny*, in the 2d Book 13th Chap. of his *Natural History*, where he says, *Elapsis ducentis viginti duobus mensibus Eclipses in orbis suos redire.* Now some there be, who says that *Pliny's* meaning was, That all the variety of Eclipses are finished in that space of time. But this is but an Idle gloss; for albeit in the same space of time, the Head of the Dragon goeth once about the Zodiack, and the Eclipses may happen thereby near the same time and place again, yet notwithstanding they are not therefore the same, that is to say, of the same quantity and duration; for certain is the Rule, *Celi motus inter se sunt incommensurabiles, nec unquam Phenomena eodem prorsus modo recurrere possunt.*

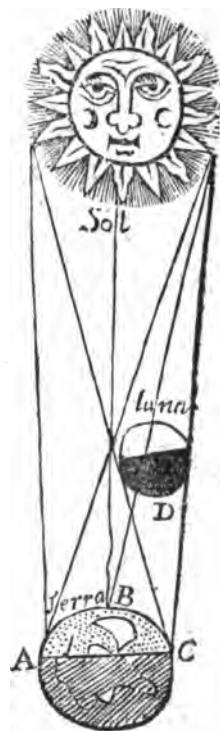

II. *Of the Eclipse of the MOON.*

THE Moon having no Light but what she receiveth of the Sun; can never be Eclipsed but at the Full, but when she is Diametrically opposite to the Sun, and the Earth, in the midst between them both. Hence the Philosophers rightly defined it, that is, *Privatio Luminis in Luna orta à diametrali terra inter Solem & Lunam oppositione.* And *Lucan* also, *Lib. 1. Pharsali* sheweth the cause of the Moons Eclipse.

— *cornique coacta,*
Jam Phæbe toto cum redderet orbe
Terrarum subita percussa expalluit umbra.

Therefore the Moon being full of Light, and exactly opposite to the Sun in the Head or Tail of the Dragon, may be totally Eclipsed, and deprived of Light by the shadow of the Earth; for the Earth being a thick and solid Body, casteth its shadow to that part which is opposite to the Sun (whom it is that enlightneth the Moon, and all the *Aetherial Region* (*suo Lumine*) unless that point opposite to him.) When therefore the Moon at her Full, and opposition to the Sun, entreteth into that obscure part, on which the shadow of the Earth falleth, she doth thereby lose the Suns Light, and is obscure and dark; which we call an Eclipse. And here observe and be assured, that there is no Star whatsoever that can enter this shadow but the Moon alone, in regard of her propinquity to the Earth, for it is gathered

by sundry Observations made by the best Astronomers, that the shadow of the Earth is Conical the quantity of the extent (*a centro Terræ*) being 250 Semi-diameters, and the Moon being farthest remote in *Apogæo*, is distant from the Earth but 58 Semi-diameters; from hence therefore it appears, that the Moon may enter into the said shadow, but not any of the other Planets; and although *Venus* and *Mercury* are sometimes within the said limits, yet they are always nigh the Sun, and are never opposite to him; so that this Massy Globe of the Earth can never interpose theby, to hide the Suns glorious Beams from them. As for *Mars*, he is (in his mean motion) from the Earth 1745 Semi-diameters; to which place the Cone of the Earths shadow never extendeth. And although the Moon is opposite to the Sun every month, she is not therefore Eclipsed in every opposition but then only, when at the opposition she is found in or near the Ecliptick, having then little or no Latitude.

Moreover, the Astronomers (the better to measure the quantity of the Eclipse) do divide the Diameter as well of the Sun as of the Moon, into 12 equal parts, which they call Points or Digits, and the more Digits the Eclipse is, the greater is the Eclipse. Yet in the Eclipses of the Moon, we must know that the Diameter of the shadow is far greater than the Diameter of the Moon. Hence the Moon, being in the middle of the said shadow which answereth the Line of the Ecliptick exactly, the whole body of the Moon is not only obscured 12 Digits, but the obscuration is enlarged much by the plunging of the Moon (as it were) into the said dark shadow, and her long continuance there; and therefore in Lunar Eclipses, we reckon the number of Digits according to the quantity of the shadow of the Earth, which may sometimes extend to almost 23 Digits.

A Type of the Moon's Eclipse according to Ptolomy.

Wherefore we usually reckon three sorts of Eclipses, the first partial, when her whole Body is not darkened, but some part thereof. The second, when her whole Body is darkened exactly; and this is called a total Eclipse, but without continuance. The third, when she happens into the shadow of the Earth more than 12 Digits; and this is called a total Eclipse with continuance, or stay in darkness; All the difference whereof ariseth principally from the Latitude of the Moon, and her distance from the Ecliptick Line. But of these things (*Deo permittente*) more amply hereafter in another Work.

In this Diagram you may observe when the Eclipse is total, when partial; and when there is none at all in the opposition.

More concerning the Eclipses.

The two foregoing Schemes declare the reason of the



Eclipses of the Sun and Moon according to the *Ptolomean* System, where the Earth is supposed to be the Center of the Universe: But this Scheme demonstrates the same by the *Copernican* System, where the Sun is supposed to be the Center of the Universe, in which Scheme or Figure,

A Type of the Sun and Moon's Eclipse according to Copernicus.

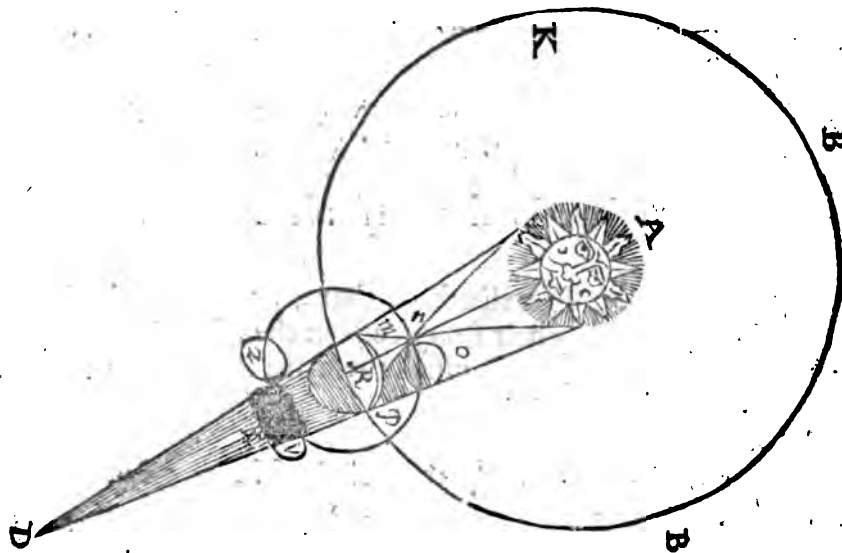

I. For the Eclipse of the Sun:

- A, Represents the *Sun*, and Center of the *World*.
- B, K, R, B, The *Annual Orb* of the *Earth*.
- R, The *Body* of the *Earth*.
- S, Z, V, S, The *Orb* of the *Moon*.
- O, The place of the *Moon* when she is in *Conjunction* with the *Sun*.
- V, X or Z, Her *Place* when she is in *Opposition*.
- D, The *Conical Point* of the *Earths Shadow*, which is *greater or lesser*, according to the distance of the *Earth* from the *Sun*.

Now, by this *Figure* it appears, that to him that stands upon the *Earth* at N, the whole *Body* of the *Sun* is hidden from his sight by the interposition of the *Moon* at O. But to him that is at R, there is but half the *Sun* obscured. And lastly, To him that lives at M, there is no part of the *Suns* *Body* hid from him; but he, at the same *Instant*, may behold his whole *Body* free from any interposition of the *Moon*, as is plainly represented in the *Figure*.

II. For the Eclipse of the Moon:

When the *Moon* is in exact *Opposition* to the *Sun*, and void of *Latitude*, as she is when placed at X, for then the Center of the *Earths* *Shadow*, whereby she loseth the whole *Light* of the *Sun*, by the direct interposition of the *Earth* between the *Sun* and *Her*; whereby *She* is totally

R E C R E A T I O N S

tally *Eclipsed* with *Contrivance*: But if she be in the Points *V* or *Z*, then her *Eclipse* is *Partile*; and only a *Part* of her *Body* is darkned; and if her *Latitude* (at the time of her *Opposition* with the *Sun*) be so great *Northward* or *Southward*, that it be out of the *Verge* of the *Conte* of the *Earths Shadow*, as at *C* or *D*. Then she is free from all obscurity thereby, and so suffers no *Eclipse* at that *Opposition*: All which Positions the *Figure* plainly *Demonstrates*.

C H A P. X.

Of some Passions of the Planets.

I. **T**HE Planets, in respect of that Motion which they make, according to their Longitude in the *Ecliptick*, are subject to several *Passions*, of which these are the Chief.

1. *Direction.*
 2. *Retrogradation.*
 3. *Station.*
- } In Respect of their *Motion*; For

First, A Planet is said to be *direct* in Motion, when it moveth forward, agreeable to the Order and Succession of the *Signs*; as from *Aries* to *Taurus*, *Gemini*, &c.

Secondly, A Planet is said to be *Retrograde* in Motion, when its Motion is contrary to the Order and Succession of the *Signs*; as when a Planet moveth from *Cancer* to *Gemini*, and so to *Taurus*, &c.

Thirdly, A Planet is said to be *Stationary*, when in its change between *Direction* and *Retrogradation*, the change is not in a small time perceptible, and seemeth to continue in the same place for some days together; and so is said to be *Stationary*.

II. The Planets among themselves, in respect of their Longitudes in the *Ecliptick*, are subject to several *Aspects*, as principally these five.

1. *Conjunction.*
2. *Opposition.*
3. *Trine.*
4. *Quartile.*
5. *Sextile.*

First, *Conjunction* is when any two Planets are in one and the same *Sign* and *Degree* of the *Ecliptick*, as if *Saturn* be in 16 deg. of *Gemini*, and *Mars* be there-also; then there is said to be a *Conjunction* of *Saturn* and *Mars*, which the Astronomers do thus Characterize σ η δ .

Secondly, *Opposition* is when any two Planets are in opposite *Signs* of the *Ecliptick*, or are just *six Signs*, or a half Circle, distant from each other; as if *Jupiter* be in 10 deg. of *Aries*, and *Venus* in 10 deg.

of

of *Libra*, then there is said to be an *Opposition* of *Jupiter* and *Venus*, which is thus expressed in Characters $\text{♄} \text{ } \text{ } \text{♀}$.

Thirdly, *Trine*, Two Planets are said to be in *Trine*, when they are four Signs (or one third part of a Circle, which is 120 deg.) distant from each other. As if the *Sun* be in 25 deg. of *Taurus*, and *Mars* in 25 deg. of *Virgo*, then there is a *Trine* of the *Sun* and *Mars*, which they thus express $\Delta \odot \delta$.

Fourthly, *Quartile*, Two Planets are said to be in *Quartile Aspect*, when they are distant from each other three Signs (or one Quadrant, or quarter of the *Ecliptick*, which is 90 deg. distant from each other,) as if the *Moon* be in 6 deg. of *Pisces*, and *Mercury* in 6 deg. of *Gemini*, then there is a *Quartile Aspect* between those two Planets; and is thus Characterized $\square \text{ } \text{ } \text{♁}$.

Fifthly, *Sextile* is when two Planets are two Signs in the *Ecliptick* distant from each other; as if *Saturn* be in 12 deg. of *Cancer*, and *Jupiter* in 12 deg. of *Virgo*, then do those two Planets make a *Sextile Aspect*, and are thus expressed in Characters $\ast \text{ } \text{ } \text{♃}$.

Venus and *Mercury* cannot make any of these Aspects with the *Sun*. Neither can *Venus* and *Mercury* make any of them between themselves; except the *Sextile*; which they often do.

III. The Planets Places in the *Ecliptick*, being compared with the *Sun's* Place, they are either,

1. *Combust*.

2. *Oriental*.

3. *Occidental*.

First, A Planet is said to be *Combust*, when it is so near the *Sun*, that it cannot be seen, by Reason of the *Sun's* Bright Rays.

Secondly *Oriental*: A Planet is said to be *Oriental*, when it Rises in the Morning, and may be seen in the *East* before the *Sun* Rises.

Thirdly *Occidental*: A Planet is said to be *Occidental*, when it may be seen in the *West* some time after the *Sun* is set.

IV. Of the *Poetical* Rising and Setting of the *Stars* and *Planets*; and they are principally three, *Viz*:

1. *Cosmical*.

2. *Acronical*.

3. *Heliacal*.

First, A *Star* or *Planet*, is said to *Rise Cosmically*, when it Risetb with the *Sun*, or with that degree of the *Ecliptick* in which the *Sun* then is: And it is said to *set Cosmically* when it setteth in the *West* in the Morning, at such time as the *Sun* is Rising in the *East*.

Secondly, A *Star* or *Planet* is said to *Rise Acronically*, when it Risetb in the *East* Horizon, at such time as the *Sun* is going down in the *West*: And the *Acronical setting*, is when a *Star* or *Planet* goeth down, or setteth with the *Sun*.

Thirdly, A *Star* or *Planet* is said to *Rise Heliacally*, when having been some time *Combust* (or hidden under the *Sun* Beams) begins to appear: And *Heliacal setting* is some small time before it comes to be *Combust*.

Now

R E C R E A T I O N S.

Now to know when a Star or Planet begins to become Combuſt, and when to be freed from his Combuffment of the Sun's Beams, no certain Rule can be given; for the Magnitude of the Star; the Difference of the Climate; the Cloudineſs or Serenity of the Air may much alter: But the Opinion of the Ancient Aſtronomers was; That

A Star of the	{	First Second Third Fourth Fifth Sixth	} Magnitude may be ſeen, when the Sun is but	{	12 13 14 15 16 17	} Degrees below the Horizon.
------------------	---	------------------------------------------------------	-------------------------------------------------	---	----------------------------------	---------------------------------

But thoſe which are only Nebulous cannot be ſeen until the Sun be 18 Degrees below the Horizon.

C H A P X I.

*Containing the Rudiments of Astronomy, put into plain Rhyme,
by Mr. John Palmer, M. A.*

I. Of the Circles of the S P H E R E.

SIX Great Circles mark you ſhall;
Which Equally divide this Ball:
Juſt in the miſt, between the Poles,
From Eaſt to Weſt th'Equator Rolls,
Th'Ecliptick cuts him, and doth ſlide
Scarce Twenty Four Degrees ſide
Horizon even with the Ground,
From Stars below our ſight doth bound:
Meridian Upright doth Riſe,
Parting the Eaſt and Weſtern Skies:
Two Colures through the Poles do Run,
Quartring the Circle of the Sun,
One where the Spring and Fall begin,
Th'other where Longeſt Days come in.

Four Leſſer Circles (Mark them well)
Are to th'Equator Parallel:
Two Tropicks Bound the Sun's High-way,
Shewing the Longeſt and Shorteſt Day:
The Arctick Circle cuts the Bears,
Th'Antartick Oppoſite Appears.

Meridians

Meridians *half Twenty Four,*
 For Hours, and for Degrees, *Nine Score,*
 Through both Poles of the World do pass,
 And th' Equinoctial downright crosses;
 And *Nine Score* Parallels bath that Line,
 By which Stars North and South Decline.
 Th' Ecliptick bath his Longitudes,
 And Parallels of Latitudes
 For Stars; but in Geography,
 The Towns beside th' Equator lie.

Over our Head, and under Feet,
 The *Nine Score* Azimuths do meet;
 And here as many Parallels
 Of Altitude Horison tells.

Longitudes and Meridians all,
 And Azimuths Great Circles call;
 But all their Parallels in Heaven
 Being lesser, cut the Globe uneven.
 Degrees *Three Hundred and Three Score,*
 Hath every Circle; and no more.

II. Of the Constellations of the Fixed Stars.

THE Army of the Starry Sky,
 Declare the Glory of God most high;
 Seen and perceived of all Nations,
 In Eight and Forty Constellations.

First, Near unto the Northern Pole,
 The Dragon and two Bears do Roll,
 Whose hinder Parts and Tails contains
 The lesser and the greater Wains:
 The Hare, the Bearward, and the Crown,
 And then comes Hercules kneeling down;
 And next below a place doth take,
 Great Serpentarius with his Snake,
 Under the Harp of Orpheus,
 The Eagle and Antinous;
 The Silver Swan her Wings doth spread:
 Above the Dart and Dolphins Head;
 Then Pegasus comes on amain,
 Andromeda follows in her Chain;
 The Triangle below her stands,
 And at her Feet is Perseus Hands.

R E C R E A T I O N S.

*The Gorgons Head above are seen
Her Parents, Cephus with his Queen
Cassiopea: Not far below
Heniochus his Goat doth shew
On his Left Shoulder, in his Hand
He doth the Stormy Kids Command.*

*Here in the Zodiack begins
The Lamb, the Bull, the Loving Twins;
The Crab, the Lion, and Virgin Tender,
The Ballance, Scorpion and Bow-bender;
Goat, Waterman and Fishes twain,
Shall bring you round to th' Rain again.*

*Fifteen Images appear
In the Southern Hemisphere;
The Monstrous Whale before the rest,
Eridanus scarce wets his Breast;
Over the Hare, Orion bright
sparkles in a Winters Night;
Then comes the Great Dog at his Tail,
And famous Argo spreads his Sail;
Above the Little Dog doth flame,
For whom the Latines had no Name.
Long Hydra on her Tail a-low
Carries the Pitcher and the Crow;
The Centaur holds the Wolf by th' Tail;
The Altar and Ixions Wheel
Are never seen of us; But here
The Southern Fish brings up the Rear.*

III. Of the Seven Planets.

U*nder those Fixed Stars above
Seven Planets in their Orbs do move.
The high'st is Saturn; Thirty Year..
He spends in Compassing his Sphere.
Twelve Jupiter; and Mars in twain
Sets forward, and comes round again.
Then in one Year the Sun displays
Three hundred Sixty and Five days;
And near a Quarter, which in Four
Encompassing, makes one Day more.
Between the Sun and us there fly
Fair Venus and swift Mercury.
These always near the Sun we find,
Not far before, nor far behind.*

The

ASTRONOMICAL.

35

The Moon; the lowest, who in Seven
And Twenty Days goes round the Heaven;
And above two Days more does Run,
Before she overtakes the Sun:
So Twenty Nine Days and an half in all,
Do make a Month Synodical.
These Planets make their Course to th' East,
Though they be faster hurled West;
And Six Degrees the rest may stray,
Besides the Suns Ecliptick way.

SANDYS upon Psal. 8.

When I, pure Heav'n, thy Fabrick see,
The Moon and Stars create by thee;
O! what is Man, or his frail Race,
That thou should'st such a shadow grace?

CHAP. XII.

Of the Constellations of the Fixed Stars, Giving an Account
of their English, Greek, Hebrew, Latine, Arabick, Cal-
dee, Syriack, Turkish, &c. Names; and of the most Emi-
nent Stars in each of them: With the Poetical Fables,
declaring how these Asterisms came to be placed in the
Heavens; and also of the Galaxia.

I. Of the Zodiacal Constellations.

A R I E S.

This Sign is called by the Greeks *Kædis Chrysomollas*, Jupiter Am-
mon; by the Egyptians or Copties *Tapretouto Ammon*, i. e.
Regnam Ammonis; in Hebrew *Tele*; in the Syriack *Emro*; by the A-
rabians *Al Hâmal*; by the Persians *Bèrri*, or *Bère*; by the Turks *Kæsi*.
All signifying a *Lamb full grown*. In this Constellation are reckon'd 17
Stars, whereof 4 informes; i. e. Placed without the Figure. This,
according to the Tradition of the Egyptians, was made a Constella-
tion in Honour of *Cham*. But as *Nigidus*, for discovering to *Bacchus*,
and his thirsty Army in the Desarts of *Africa*, a Fountain of Water;
Or, as *Pherecidas*, for transporting of *Phryxus* and *Helle* over the Sea;
E 2 flying

flying from their Step-Mother *Ino*. *Schillerius* will have this Constellation Attributed to *St. Peter*; and *Schickardus* to *Abrahams Ram*, offered in the Room of *Isaac*. This Sign was first discovered by *Cleostratus* and *Tenedian*; and it comes to the Meridian at Midnight, about the end of *October*, and beginning of *November*.

T A U R U S.

THis Sign is called by the Egyptians, *Jo*, *Isis*, *Apis*, and *Orias* i. e. *Statio Hori*; by the Greeks and Latines, *Ταυρος* and *Taurus*; in Hebrew, *Shôr*; by the Arabians, *Al Taur*; by the Syrians, *Thauro*; by the Persians, *Ghau*; and by the Turks, *Ughuz*, i. e. *Bos*.— This Constellation consists of 44 Stars, whereof 11 shapeless: Of these there is one of the first Magnitude, called by the Greeks *λαμπαδία*; by *Ptolemy*, *ὀπὸν ἑσος*; by the Arabs *Aldebaran*, i. e. *Stella Dominatrix*, and *Aim Al Thaur*, i. e. *Oculus Tauri*; by the Egyptians, *Piorion*, i. e. *Statio*, *sen Dominium Hori*; in regard of the Power of the Sun in Conjunction with that Star; by the Romans *Palilicium*, because heretofore it rose at *Rome* on the Feast Day of *Pales*.— It was Translated into Heaven in Memory of the Raper of *Europe* by *Jupiter* in that shape; or in Honour of *Jo*, or *Isis* Transformed by *Juno* into a *Cow*, and Constellated by *Jupiter*. Others will have it to be the Symbol of *Osyris* or *Meforis Mizraim*, the Son of *Cham*, who first taught the Egyptians Tillage; or rather, of the Patriarch *Joseph*, for his preserving *Aegypt* in the time of *Famine*. *Schillerius* will have this Constellation Attributed to *St. Andrew*; but *Harsdofius*, to the Offering of *Burnt-Sacrifice* commanded, *Levit. 1. 3.* About the end of *November*, and beginning of *December*, this Constellation may be seen upon the Meridian at *Midnight*.

G E M I N I.

These are called by the Greeks and Latines *Δίδυμοι*, *Tindarida* and *Dioscuri*; in the Coptick, *Clufos*; i. e. *Clustrum Hori*; in the Hebrew *Termin*; in Syriack, *Tôme*; in Arabick, *Taw Amân*, i. e. *Gemelli*; they are likewise by the Arabs called *Giauzu*; others derive it from *Gianz*, signifying a *Nut*; and therefore the Turks call this Sign *Kûs Siphelû Burgi*, i. e. *Nucem, vel Nuces referens Signum*; by the Persians *Ghirdegân* to the same sense. There are reckoned in this Constellation 25 Stars, whereof 7 Informes: The Star in the Head of the Western Twin is called by the Arabs *Ras al Tawum Almukeddem*, i. e. *Caput prioris Geminorum*; the other, *Ras al Tawum Munaccher*, i. e. *Caput posterioris Geminorum*: The two Stars opposite one to the other in the Feet of the said Gemini are by the Arabs called *al Hen'a*; *Varro* will have them to be *Apollo* and *Hercules*; others will have them to be *Triptolemus* and *Jason*; some *Amphion* and *Zethus*: But with greatest probability they are conceived to be *Castor* and *Pollux*; *Δουρά*, i. e. *Trabalia*, being no other than two *Wooden Posts set parallel one to another*, and joyned together at each end by two other transverse *Beams*. Hence, saith the Learned *Palmerius*; Astrologers make use of the like Figure or Character; to denote this *Twyn Sign*; which they derived from

from the *Lacedemonians*—*Schillerius* will have this *Constellation* to signify *St. James* the Elder; but *Schickardus*, *Jacob* and *Esa*—It comes to the Mid-Heaven at Midnight, in the end of *December* and beginning of *January*.

C A N C E R.

THis Sign is in the Greek called *Καρκίνος* and *Ουρανός*, i. e. *Ostipes*; it is likewise called *Nepa Astracus*, *Camarus*; in Arabick, *Alferdem*; in Hebrew *Sartan*; in Syriack *Sartono*; in Persian *Chercjengh*; by the Turks *Lenkutch* or *Lenkitch*; and *Tenkutch*; or *Tenkitch*, and *Tilénkutch*, or *Tilenkitch*; i. e. *Cancer*; in the Coptick it is called *Klavra*, i. e. *Bestia*, seu *statio Typhonis*. The whole *Constellation* is made up of 13 Stars, of which 4 shapeless. Amongst which the first Star is called in Arabick *Malaph*, i. e. *Præsepe*; or the *Mainger*; in Greek *μαζμή*; it is likewise by the Arabs called *Al Neshra*; in Chaldie *Pesebre*; and it is a *Cloudy Star*; by *Gabieus* discovered to consist of 36 smaller ones—This *Crab* was made a *Constellation* at the Intreaty of *Juno*, being kill'd by *Hercules*, for biting him by the Foot, when he encountred *Hydra*. The *Assyngoes* with their *Mainger*, were *Constellated*, because of the Fight with the Gyants, *Bacous* and *Vulcan* charged upon *Asses*, who with their Brayings Frighted; and so put to Flight their Enemies. *Schillerus* will have this *Constellation* ascribed to *St. John* the Evangelist.—This Sign is Famous according to the *Chaldaick* and *Platonick* Philosophy; for being supposed the Gate by which Souls descended into Humane Bodies. This *Constellation* may be seen about Midnight, almost all the whole Month of *January*.

L E O.

THis Sign is by the Greeks called *Λέων*; in Hebrew *Ar'yes*; by the Arabs *Al Asad*; in Syriac *Ar'yo*; in the Persian *Shir*; the Turks call it *Arslan* or *Arslin*, i. e. *Leo*; the Egyptian Coptics call it *Pimen-tekeon*, i. e. *Cubitus Nili*. The *Constellation* consists of 39 Stars, whereof 8 inform. The first Star in this *Constellation* is by the Arabs called *Minchir al Asad*, i. e. *Nares Leonis*; The third *Ras al Asad*, *al Chemali*, i. e. *Caput Leonis Boreale*: The fourth *Ras al Asad*, *al Gienubi*, i. e. *Caput Leonis Australis*: The fifth, sixth and seventh Stars, are called by them *Gieb'ha*, i. e. *Frons*: The eighth they call *Melichi*, to which the Latine *Regulus* answers. They give it likewise the Name of *Kalb al Asad*; i. e. *Cor Leonis*, being a Star of the first Magnitude. The seven and twentieth Star they call *Serpha*, i. e. *Mutatrix*, from the Change it brings of Heat from Cold; and *Danab al Asad*, i. e. *Cauda Leonis*, and is likewise of the first Magnitude. The *Lion* was made a *Celestial Sign* by *Juno* to spite *Hercules*, by whom he was slain, and is said to have been bred in the *Moon*, and from thence to have fallen near the *Nemeaan Grave* in *Arctadix*, from whence called *Nemeaus*. *Schillerius* will have this *Constellation* attributed to *St. Thomas*, but *Schickardus* to the *Lion of the Tribe of Juda*. This *Constellation* will be seen in the Meridian at Midnight in the Month of *February*.

VIRGO.

V I R G O.

This Constellation in Greek bears the Name of $\mu\epsilon\gamma\sigma\tau\epsilon\rho\varsigma$, to which the Latine *Virgo* Answers. In Hebrew it is called *Bethula*; in Syriac *Bethulto*; in Arabic *Adra* and *Adrenodepha*; and in the Persian *Dushiz* & *Pakiza*; all to the same sense with the former. In the Egyptian or Coptick it is called *Aspholia*, i. e. *Statio Amoris*. It is likewise, in respect of the chief Star by which it is signified, being one of the first Magnitude in her Left Hand, called by the Hebrews *Shibbolesh*, by the Syrians *Shewolto*; by the Arabs *Sumbela*; by the Persians *Chûsbe*; and by the Turks *Salkim*; all signifying a Spike or Ear of Corn. In this Constellation *Ptolomy* reckons 32 Stars, of which 6 inform. The sixth and seventh Stars in this Constellation are by the Arabs called *Min al Awa*, de *lacratore*; and so likewise the Tenth; The seventh is by them called *Zawija al Awa*, i. e. *Angulus Lacratoris*: The Thirteenth, which is also one of the first Magnitude in her Right Wing, called by *Proclus Praxindemiator*, is by the Arabs called *Muhdim al Ketaph*: The Fourteenth, which is the *Spica*, *Simak al Aza*, i. e. *Efferens Inermem*, Scil. *Virginem*; to distinguish it from another Star in *Bootes* called *Simak al Ramih*, i. e. *Efferens Hæbiferum*. The 22d, 23d, 24th and 25th Stars are called *Min al Gapbr*, i. e. *Ex al Gapbr*, which signifies *Velamen*, *Ventrem & Testuram*, quod *Stella ejus obtecta sunt*. This Sign, according to the Vulgar Opinion, is taken for *Astræ*, or *Justice*; by others for *Erigone* Daughter of *Leonus*; others suppose her to be *Ceres*, *Quod spicas teneat*; others call her *Atergatis* the Goddess of the *Assyrians*; some will have her to be *Fortune*. *Avienus* makes her to be *Isis*; and others again will have her to be *Concord* or *Peace*. *Schiblerius* attributes her to *St. James the Younger*; but *Schickardus* will have it the *Virgin Mary*. This Constellation visits the Meridian at Midnight about the end of *March*, and beginning of *April*.

L I B R A.

This *Asterism* is called by the Greeks $\lambda\iota\beta\rho\alpha$, $\tau\alpha\beta\alpha\lambda\alpha$, and $\tau\alpha\beta\alpha\lambda\alpha$; to which the Latine *Libra* Answers. By *Cicero* it is called *Jugum*; answering to the last of the Greek Names. In Hebrew it is called *Mozanaim*; in Syriac *Masâho*; in Arabick *Al Mizan*; by the Persians *Terazu*; all signifying *Libram*, *Stateram*, seu *Balançem*. The Turks use the Arabick Name *Mizan*, which in their Language is *Tartagick alati*, i. e. *Ponderandi Instrumentum*. In the Coptick it is called *Lambadia*, i. e. *Statio Propitiatiois*. This Constellation is made up of Seventeen Stars, whereof Nine inform; among which, the first Star by the Greeks called $\chi\epsilon\lambda\alpha$ $\nu\alpha\upsilon\tau\iota\sigma$; is by the Arabs called *Zubânâ Giannbi*, i. e. *Chela Australis*, and *Al Kiffa*, *Al Giannbija*, i. e. *Lanx Australis*; The third Star called by the Greeks $\chi\epsilon\lambda\alpha$ $\beta\omicron\rho\epsilon\iota\sigma$, is accordingly called by the Arabs *Zubânâ Shomâb*, i. e. *Chilo Borealis*, and *Al Kiffa al Shemâlija*, i. e. *Lanx Borealis*. There is no distinct Fa-
ble

ble of this Sign, it being part of *Scorpius*. Yet *Schillerus* attributes it to *St. Philip* and *Hartsdorsius*, to the *Tekel* or *Ballance* of *Belsbasar*, *Dan. 5. 27.* This *Asterism* mounts the *Meridian* at *Midnight* about the beginning of *May*.

S C O R P I O.

THE Hebrews call this Sign *Akrab pro Akatzrab à magno oculo*: The Syrians call it *Akrevo*; The Arabs *Al Akrab*; The Persians *Ghezidum*; The Turks *Koirughi*, quasi *Kar' iξoxv*, *Caudatus*, or *Uzum Koirughi*, i. e. *Longa Cauda præditus*; By *Cicero* it is called *Nepo*, which *Festus* says is an African Word; By the Greeks *Σκorpion*; and by the Egyptians *Copties Isias*, i. e. *Statio Isidis*.—There are counted therein 24 Stars, whereof 3 Shapeless: The 6 first are by the Arabs called *Iclil al Gieb'ha*, i. e. *Corona Frontis*: The 6th is particularly called *Gieb'ha al Akrab Frons Scorpii*: The 8th is of them called *Kalb' al Akrab*, i. e. *Scorpii*, &c.—The *Scorpion* is Fabled to have been made a Constellation for having slain *Orion*, who boasting he would in Hunting destroy all the Wild Beasts in the Forrest; Or, according to *Nigidius*, For that Hunting with *Diana* in the Mountain *Chilippus* in the Island *Chios*, he contemned and derided Her as inferior to him in Skill; Or, according to *Palæphatus* and *Nicander* in *Theriac*, for daring to have violated her Chastity; for which, in Revenge, she is said to have sent this *Scorpion* to Sting him to Death, as he was, for which, at her Request, by *Jupiter* he was made an *Asterism*, (*Schickardus* ascribes it to *St. Bartholomew*) and is seen to crawl towards the *Meridian* of *Midnight* about the end of *May*, and beginning of *June*.

S A G I T T A R I U S.

THIS Constellation is in Hebrew called *Kesbeth*; In Syriack *Kesbto*; in Arabick *Alkans*; in the Persian Tongue *Kaman*; in the Turkish *Yai*; all signifying an *Arrow*: In Greek *τεβης* according to which signification it is likewise by the Arabs called *Rami*; by the Egyptians *Pimaere*, i. e. *Statio Amanitatis*.—It consists of 31 Stars, of which the first is by some of the Arabians called *Zugo al Nusbaba*, i. e. *Cuspis, vel Ferramentum Spiculi*: The 8th Star in this Constellation is by the Arabs called *Ain al Rami*, i. e. *Oculus Sagittarii*: The 23d *Urkub al Rami*, i. e. *Suffrago*, the Hough or Postern: The 24th *Rukba al Rami*, i. e. *Genu*, the Knee of *Sagittarius*.—*Hyginus*, from the Authority of *Sosithens*, will have this to be *Crotus*, the Son of *Euphemis*, or *Euthemis*, the Nurse of the Muses, at their Instance, by *Jupiter*, placed in the *Zodiack*. Others will have him to be *Chiron*. This Sign, at *Midnight*, will be upon the *Meridian* about the end of *June*, and beginning of *July*.

CAPRICORN.

C A P R I C O R N.

THE Greeks give to this Sign the Name *Αρβουρος*, ὁ Ἄρπυριος; The Latines *Hircus Equoris*: In Hebrew it is called *Gedi*; in Syriac *Gadio*; in Arabick *Al Giedi*; in the Persian *Buzeghale*; in Turkish *Uglack*; all signifying a Kid or Goat. In the Coptick or Ægyptian Tongue it is called *Hopentus*, i. e. *Brachium Sacrificii*. It is made up (by the general assent of Astronomers) of 29 Stars, of which the first and third are by the Arabs called *Min Sad al Dabih*, i. e. *Ex fortuna Maſtantis*; and simply, *Dabigh*, i. e. *Maſtans*. The 23d and 24th Stars are called by them *Sad Naſhira*, i. e. *Fortuna averruncantis, vel divulgantis Nuncium*; But the 24th, by a particular Name from its situation, is called *Danab al Giebi*, i. e. *Cauda Capricorni*.---This was made a Constellation in honour of *Ægipan* the Son of *Jupiter*, by the *Olenian Goat*, or rather his Foster-Brother, Son of *Æga*, the Wife of *Pan*, whence his Name; who as *Bassus*, in *Germanic*, from the Authority of *Epimenides* writes, assisted *Jupiter* in his Wars against the *Titans*, and Armed the Gods, and for that reason honoured with this Celestial Dignity. The reason of his being Figured half Goat half Fish, *Theon*, the Scholast of *Aratus* reports, was, That he finding on the Sea shore an empty *Murex*, or Purple Shell, is said to have wound it like a Horn, thereby striking a Panick fear into the *Titans*, and therefore they represented him with a Tail like a Sea Monster. Celebrated it is, according to the Doctrine of the *Pythagoreans* and *Platonists*, for being the Gate by which Souls ascend into Heaven, and therefore stiled *Porta Deorum*. *Schillerus* ascribes this Asterism to *S. Simon*: It ascends the Mid-heaven at Midnight about the end of *July*, and beginning of *August*.

A Q U A R I U S.

THIS Sign is by the Greeks called Ἰδρυξ, by *Appian*, *Hydrivurus*; and in the same signification by the Arabs, *Sakib al Ma*, i. e. *Esfusor Aqua*. It is by them likewise called *Al Delu*; and in Hebrew *Deli*; in Syriac *Danto*; in the Persian Tongue *Dul*; in the Turkish *Kugha*; all signifying an Urn, or Watering-Pot. The Ægyptians or Copties call it *Hupentheron*, i. e. *Brachium Beneficii*. There are reckoned therein, according to *Ptolomy* and *Kepler*, 45 Stars, whereof 3 inform. Of these Stars, the 2d and 3d are called in Arabick *Sa'd al Melick*, or *Sa'd al Mulck*, the first signifying *Fortuna Regis*, the latter *Fortuna Opum & Substantie*. The 4th and 5th are called *Sa'd al Sand*, i. e. *Fortuna fortunarum*; under which are some other Stars of less Note, called *Al Ana*. The 6th and 7th are called *Sa'd Bula & al Bulaan*, i. e. *Fortuna Delutientis, or Delutientium*. The 9th, 10th, and 11th Stars are called *Sa'd al Abbija*, i. e. *Fortuna Tentoriorum*: The 14th Star in this Constellation being one of the first Magnitude,
is

is in Arabick called *Diphda al Auwal*, i. e. *Rana prima*. It is likewise called *Phom al Haut al Gienubi*, i. e. *O₃ Piscis Australis*, and commonly, but corruptly. *Phomahant*. This Asterism is by some Fabled to be *Ganymede*, the Cup-bearer of *Jupiter*; by some *Deucalion*: (whence by *Vomanus* this Sign is intituled *Deucalionis Aquæ*) By others *Aristæus*. By *Schillerus* this Sign is attributed to *St. Jude*, but by *Schickardus* to *Naaman*, 1 Reg. 25. 14. — It is seen in the Meridian at Midnight, about the end of *August*. and beginning of *September*.

P I S C E S.

THis Sign in the Greek is called *Ἰχθύων ἀπειροῦς*, and by the Jews accordingly, *Dagaim*, i. e. *Duo Pisces*; but the Arabs call it *Al Haut*, & *al Samaca*; the Syrians *Nano*; the Persians *Mahi*; the Turks *Balick*; which signifies a *Fish* in the singular Number; so likewise in the Coptick it is called *Pikotoron*, i. e. *Piscis Horii*. The Northern of these Fishes is in the Arabick called *Haut Alsbemali*, i. e. *Piscis Borealis*, and is known by the peculiar Name of *χελιδνας*, as being represented by the Chaldeans with the Head of a *Swallow*; the reason; as *Scalizer* conceives, because when the Sun is in this Sign, the *Swallow* begins to appear in those Regions: The Southern is called *Haut al Gienubi*, i. e. *Piscis Australis*. The whole Constellation consists, according to *Ptolomy*, of 38 Stars, whereof 4 inform. The Stream, or *Tenuis fusio Stellarum utriusque Piscibus disposita*; *Vitruvius* calls *Mercurii Domum seu Delicias*, which *Scaliger* conceives ought to be read *Lagneam*; or as *Pliny* terms it, *Commissuram Piscium*. The Arabians call it *Cheit*, vel *Cheit Kottani*, i. e. *Filum Linteum*. — These are Fabled to be the Syrian Deities, according to *Germanicus*, *Syria duo Numina Pisces*; by which are understood *Venus* and *Cupid*, as *Hyginus* (from the Authority of *Diogenes Erythraeus*) writes. For *Venus*, and her Son *Cupid*, coming to the River *Euphrates*, and frighted at the sudden appearance of the Giant *Typhon*, cast themselves into the River, and assumed the shapes of Fishes, by which means they escaped from danger: For this reason the Syrians abstain from Eating of Fish, lest they might happen to Eat up their Deities: But the Scholiast of *Germanicus* (from *Nigidius*) writes, That these were the Fishes which turn'd or roll'd up upon the Bank of *Euphrates* a great Egg, upon which a Dove sitting, Hatch'd *Venus*, the Syrian Goddess. *Schillerus* will have these attributed to *St. Matthias*; but *Schickardus* to the two Fishes in the Gospel, *John 6. 9*. — This Asterism may be seen in the Meridian at Midnight, almost the whole Months of *September* and *October*.

II. Of the Ancient Northern CONSTELLATIONS.

H E L I C E.

SO Named by the Greeks; it is also called *Ursa Major*, &c. *Plaustrum Majus*; in Arabick *Dub Ackber*; it is likewise by the Arabs called *Benat al Nash al Cubra*, i. e. *Filia feretri Majoris*, in regard the 4 Stars that make the Body of the Bear resemble a Bier, and the Three in the Tail, the *Virgins* or *Maid*s that Attend the Corps: And for this Reason, the Christian Arabs call the four Stars *Nash Laazar*, i. e. *Feretrum Lazari*; and the Three in the Tail, *Mary Magdalen*, *Martha* and their *Maid*; by the Persians it is called *Haphiurengb Mihin*, i. e. *Septentrio Major*; and by the Turks, *Tidigher Tilduz*, i. e. *Septena stella*, and by the Latins, *Septem Triones*. This Constellation consists of 35 Stars, whereof 8 inform. Of these Stars the 12 and 13 are called in Arabick *al Nekra al Thâlisha*, i. e. *Cotyle*, *Scrobs seu Cavitas ossis Tali*; the 16 *Dubr al Dub al Ackber*, i. e. *Dorsum Ursa Majoris*; the 17 *Merak al Dub al Ackber*, i. e. *Epigastrium Ursa Majoris*; the 18 *Migres al Dub al Ackber*, i. e. *Uroxigium Ursa Majoris*; the 19 *Phaid al Dub al Ackber*, i. e. *Femur Ursa Majoris*; and these four last Named make up *al Nash al Cubra Feretrum Majus*. The 20 and 21 are called *al Phikra* or rather *al Nekra*, *al Thawija*, i. e. *Vertebra seu Cotyle secunda*; the 23 and 24 *al Nekra al Ula*, i. e. *Vertebra seu Cotyle prima*. The three Stars that make the Tail are called, *al Benat*, i. e. *Filia*; whereof the first is called *al Haun*, signifying *album Nubiculum*; the second is called *al Inak*, or *al Anak*, i. e. *Capella*; the third *Alkaid*, i. e. *Gubernator*. This Constellation was first found out by *Naupilus*, and was Anciently the Greek Sea-Mens Guide; as the Lesser the *Phanicians*; The Reason is, because to the Greeks, who Sailed the *Mediterranean*, *Pontick* and *Ægeine* Seas, this Constellation was still apparent: But to the *Sydonians*, *Phenicians* and *Carthagenians*, who were more Southerly, part of the Greater Bear was either by the Position of the Sphere, or some other Accident, sometimes deprest, or obscured; but *Cynosura* always appeared to them: And therefore, these last chose the Lesser, and the Greeks the Greater Bear for their *Directress*.

Schillerus Attributes this Constellation to St. *Michael*; but *Hartsdorffus* to one of *Elisa's Bears*, 2 Reg. 2. 24. Or the Wagon of *Jacob*, or *Chariot of Joseph*, Gen. 45. 27, &c. 46. 29.

C T N O S U R A.

SO called by the Greeks, *quasi Canis Cauda*; the Hebrews call it *Genash*, i. e. *Gallinam cum Filiis suis*; by the Arabs it is called *Dub Afgher*, i. e. *Ursus Minor*, and *Benat al Nash al Sughra*, i. e. *Filia Feretri Minoris*; by some of them it is called *Agiala*, i. e. *Plaustrum*; by the Persians it is called *Haphiurengb Kihn*, i. e. *Septentrio Minor*; the Star in the extremity of the Tail, is called by the Arabs *Caucab Shemali*;

mali; i. e. *Stella Borealis*; by the Turks, *Yilduz Shemali*; and absolutely *Yilduz*, i. e. *Stella*; and by a peculiar Name in Arabick it is called *Giedi*, i. e. *Hedus*. The Italians call it *Tramontana*; and we, the *Pole*, or *North Star*. The two last and brightest in the *Feretrum*, or *Square*, are called by the Arabs *al Phercadan* or *al Pharcadein*, i. e. *Duo Vituli*. The whole *Constellation* consisting (according to *Ptolemy*) of Eight Stars, whereof one inform: Of the Fabulous *Anastrosis* of this and the former *Constellation*, *Diadorus Siculus* Reports, that these were the *Nurses* of *Jupiter*, and privately kept him from the search of *Saturn*, for which they were by him, in gratitude placed in the Heavens, and called by the Name of the two *Bears*, being Worshipped with Divine Rights, by the *Cretians* and *Sicilians*, by whom they were Styled *Dea Matres*. Others refer it to the Fable of *Calisto* and her Son *Arcas*; as *Hesiod* and *Ovid*. This *Constellation* was first discovered by *Thales* the *Milesian*, as *Hyginus* affirms, for which Reason it was called likewise *Phœnice*, from *Thales* its Inventor, being by descent a *Phœnician*, who first gave it the Name of *Arctus* or the *Bear*; but trulier so denominated from the whole Nation of the *Phœnicians*, who in their Navigations (before *Thales*) observed her as their *Directress*.

D R A C O.

THIS *Constellation* the Poets feign to have been the *Dragon* that kept the *Hesperides* slain by *Hercules*, and made an *Asterism* by *Juno*. Others will have the *Dragon* to be brought by the Giants, in their Flight with the Gods to oppose *Minerva*; and by her to have been strangled and thrown up to Heaven, and there fix'd as a Trophy of her Victory. *Schillerus* Attributes this *Asterism* to the *H. Innocents*; but *Schickardus* to *Draco Infernus*.— It is called by the Greeks *Δρακόν* *Asterion*, by the Latines *Draco*; in Hebrew *Tannin*, i. e. *Draco*; by the Arabs *Tinnin* and *Tannin*, as the *Hebrew*; it is likewise by them likewise called *Taaban*, or rather *Thuban*, and in the same sense by the Persians *Ashdeba*, which is interpreted *Serpens, qui Homines ac Bestias devorat*. Some among the Arabians give it the Name of *al Haija*, which is also appropriate to the Southern *Constellation* of the same kind. It is made up of 31 Stars; of which, the first Star in the Tongue is by the Arabs called *al Rakis*, or *Arrakis*, i. e. *saltator, seu Tripudiator*; the three next *al Awaid*, i. e. *Pulsatores Testudinis*. The 9th in the Head is called *Ras al Tinnin*, i. e. *Caput Draconis*. The 14, 15 and 16th are called *al Thâphi*, i. e. *Chytropodes*, from their Posture, representing a Skillet with Feet, *Tripon* or *Brandiron*. The 20 and 21 are called *Adphar al Dib*, i. e. *Ungula Lupi*. The 27 is called *Aldibeh*, i. e. *Victima*, as being placed before that in the Horn of *Capricorn* called *Sa'd al Dahib*, i. e. *Fortuna martantis*. This *Constellation* is seen in the Meridian about the end of *June*.

THis *Asterism* in Greek bears the Name of *Ἐγγυανὸς Ὀυλάζων*, i. e. *Ingeniculus*; and by some of the Latines *Nisus*, vel *Nixus*, quia *Laboranti similis*; by the Arabs *Giathi ala Rucheteihi*, i. e. *Incumbens Genibus*. The Number of Stars in this *Constellation* are by *Ptolomy* reckoned to be 29, of which the first is called *Ras al Giathi*, i. e. *Caput Ingeniculi*, and commonly *Aas al Aben*. That in the *Elbow* from its situation, is called *Marphak*, that in his *Wrist Mis'am*, i. e. *Carpus*, and commonly *Maasym*.—This *Constellation* some will have to represent *Thebesus* or *Ixion*; others *Orpheus* or *Prometheus*; others *Thamers* or *Thamyras* a *Thraſian* Poet; who contending with the *Muses* for Skill, and by them overcome, was punished with the loss of his Eyes; and in the Memorial of their Victory, plac'd in the Heavens in a supplicatory Posture, as deprecating his Punishment: But *Panyases* will have this *Asterism* to represent *Hercules*. This *Constellation* comes to the Meridian at Midnight in the Month of *June*.

A R C T O P H Y L A X or B O O T E S.

A*rcetophylax* and *Bootes* are one and the same *Constellation*; the First signifying *Custos Urforum*, the Latter so called ἀπὸ τοῦ Βόου, i. e. *Bovis*, ἡ ἀδὴν, i. e. *pellere*, quasi *Bovum Agitator*; but in the Eastern Tongues the same seems to be deriv'd ἀπὸ τοῦ βοῶν, i. e. *a Clamando*, whence by the Arabs called *al Auma*, i. e. *Vociferator*, and *al Neckar*, i. e. *Fossor seu Paſtinator*.—It consists of 23 Stars.—This some Fable to be *Lycan*, others *Arcas*, the Son of *Calisto* his Daughter by *Jupiter*; the Scholiast of *Germanicus* makes it to be the *Constellation* of *Icarus*; and accordingly *Propertius* stiles the *Septentriones*, *Icarus* his Oxen, in this Verse,

Flectum Icarii Sidera tarda Boves.

✕

Which *Constellation* is seen upon the Meridian at Midnight about the beginning of *May*.

A R C T U R U S.

Some will have this Star so called, quasi ab ὄψε Ἀρκτοῦ i. e. *a Cauda Urse*; but trulier, ἀπὸ τοῦ ἄρκτου, i. e. *Custos Urse*, in the same sense as *Arcetophylax*. This the Arabs call *al Simak al Ramih*, i. e. *Efferens Histeferim*; in the common Globes and Hemispheres falsely *Huzme*.

A R I A D N E S' C R O W N.

THis by the Greeks is called *στέφανος βορέως*, i. e. *Corona Borealis*, & *Prima*; and accordingly by the Arabs, *al Iclil Almani*, i. e. *Corona Borealis*, and simply *Al Iclil*, i. e. *Corona*: It is by them likewise called *al Phecea*, i. e. *Apertio*; in Hebrew *Kir Schetali*, i. e. *Corona Sinistra*; and in Chaldee, *Melphelcarti*, i. e. *Sertum Pupillæ*. The *Constellation* is in Form of a Circle not completed, and therefore by

A S T R O N O M I C A L.

43

by the Vulgar Arabs called *Käse Shekefte*, i. e. *Scutella fracta*: The brightest in this Circle being of the second Magnitude, is called *Lucida Corona*, and by the Arabs, *Nair Phecca*, i. e. *Lucida Phecca*. This *Crown*, consisting of Eight Stars, some Fable to have been of Gold: *Athenais* says it was made of a Flower or Herb called *Theseus*; others will have it to be of *Lawrel* or *Myrtle*; *Bayerus* describes it to have been composed of *Elder Leaves* mixed with *Berries*; *Photius* gives this Fable of it: They report (says he) that a certain Nymph Named *Psalacantka* in the Island of *Icaria* being in Love with *Bacchus*, endeavoured to procure *Ariadne* to his Bed; on condition he would likewise be kind to her; which *Bacchus* refusing, she plotted to do *Ariadne* a mischief: This the God discovering, he in passion Transform'd her to an *Herb* bearing her Name: But afterwards, repenting the Fact, by way of Recompence and Honour, he caus'd the *Flower* to be entwin'd about *Ariadnes Crown*, which he had already fix'd in the Skie. Now most make only *Ariadnes Crown* to be *Constellated*, yet others place *Ariadne* her self in Heaven, as *Scaliger* hath observed; and for proof whereof they add the Testimony of one of *Nero's*, and another of *Trajan's* Silver Coins, having on their Reverse, the Figure of *Ariadne* carried up to Heaven in the same manner as is represented by *Propertius*. *Schillerius* will have it our Saviours Crown of Thorns, but *Harsdersius* will have it to be Queen *Hesters* Crown, *Hest*, 2. 17.

O R P H E U S His L Y R E.

THis *Constellation* is by *Ptolomy* called *λύξας Ἀστεισμος*, and by *Aratus* *λύξας κειρωσός*, i. e. *Lyra*, *deorsum pendens*; it is likewise by the Greeks called *χάλυς*, i. e. *Testudo*; and by the Latines *Lira* and *Fidicula*; and *Vultus cadens*; for it is represented in form of an *Eagle* or *Vultur*, holding a *Lyra* Inverst. By the Arabs it is called *al Lura*, from whence comes the corrupt Name *Alabore* peculiarly Attributed to the first great Star in this *Asterism*: It is likewise called *Sulaphat*, i. e. *Testudo*; the Persians call it *Ciengh Rumi*, i. e. *Cythara Greca*: It consists of 11 Stars; whereof the first is called by the Arabs *Nes'r Waki*, i. e. *Vultur Cadens*: Some Attribute this *Constellation* to the *Lyre* of *Apollo*, others to *Orpheus*; to whom *Mercury*, who first invented it, bequeathed it, and it would refuse to sound at the touch of the Hand of any other Artist. *Schillerius* will have it represent the Manger whereon our Saviour was laid, and *Harsdansius*, *Dauids Harp*, 1 Sam. 16. 23. It is seen in the Meridian at Midnight in the end of *July*, and partly at the beginning, partly at the End of the Year.

O P H I U C U S, Or S E R P E N T A R I U S.

THis *Sign* by the Greeks called *ὀφιοῦχος*, and by the Latines *Serpentarius*; is by the Arabs called *al Hauwa*; i. e. one that keeps and Nourishes Snakes: It is commonly called *al Hangué*; by the Jews it is called *Uizea rath Hajab*, i. e. *Tenens Serpentem*: It consists of 29 Stars, whereof four inform. The first Star is called *al Rai*, i. e. *Pastor*, and *Ras al Hauwa*, i. e. *Caput Serpentarii*; the second is called *Kelb al Rai*, i. e. *Canis Pastoris*: In this *Constellation* the Ninth Star is more Eminent than the rest, and is called

called *Unuk al Haiya*, i. e. *Collum Serpentis*.—*Æsculapius* is said to have been converted into this Sign for his rare Skill in Physick, and particularly for the Cures by him done, by help of an *Herb* shewn him by a *Serpent*. *Polizelus Rhodius* Reports, that this *Ophiucus* was *Phorbis* Prince of *Rhodes*, by *Hysilla* the Daughter of *Myrmidon*, who, when that Island was extremely infested with *Serpents*, and especially by a great *Dragon*, which devoured many of the Inhabitants, is said to have clear'd the Island of the Venemous Beasts, and to have slain the *Dragon*, and in Memorial thereof to have been Constellated by *Apollo*. *Kepler* will have this *Constellation* to represent *Laocoon* the Trojan mentioned by *Virgil*. This *Constellation* reaches the *Meridian* at Midnight about the Beginning of *June*; the former part of the *Serpent* about the beginning of *May*; the hinder part about the end of *June*.

The S W A N.

THis Sign is called by the Greeks *Κύνως*, by *Ptolomy* *Opvis*, i. e. *Volucris*; by *Ovid* *Milvius*, and by others of the Latines *Gallina*; according to which last it is called by the Arabs *al Dediagic*; to which Answers the Hebrew Name *Tharnigolet*. It is likewise by the Arabs called *al Tair*, i. e. *Volucris*, and *Katha*, which is properly an *Aquatick Fowl* resembling a *Pigeon*. The Persians call it *Ispherud*; and the Turks *Baghirluk*; *Ptolomy* reckons in this *Constellation* 19 Stars, whereof two inform. The first of which is by the Arabs called *Minkar al Degjagic*, i. e. *Rostrum Gallinae*; the 4th *Sadr al Degjagic*, i. e. *Pectus Gallinae*; the 5th *Danab al Degjagic*, i. e. *Cauda Gallinae*; and *Hiersym*, i. e. *Rosa*, and *Lilium redolens*, as also, *al Rid'ph*, i. e. *qua pone est seu sequens*; because it follows four others, whereof two in the Left Foot, and two others in the Left Wing. The *Fable* of this *Asterism* is, by *Theon*, who makes this *Swan* to be placed in the Heavens not in Memorial of *Jupiter*, but in Honour of *Apollo*, as particularly Dedicated to him, being a Musical Fowl. It is upon the *Meridian* at Midnight in the Month of *July*.

The A R R O W.

IT is by *Ptolomy* called *Orvi'Asvevovus*, i. e. *Asterismus Sagitta seu Te- li*; in Arabick it is called *al Sah'm*. i. e. *Sagitta*, and in the Globes *al Hance*; in the Hebrew *Ches*: *Kircher* says it is in Hebrew Named *Satan seu Demon*; and that the Turks call it *Orsercalem*: It consists of 5 Stars. This was the *Arrow*, with which *Hercules* slew the *Vulture* that Fed upon *Promethius* his Liver: And *Promethius* being received into favour with *Jupiter*, the *Arrow* in Memorial was made an *Asterism* in Heaven; by *Cicero* called *Musator*, by others *Temo Meridianus*: It Transperes one of the *Wings* of the *Eagle*; and passes the *Meridian* at Midnight about the Middle of *July*.

The E A G L E.

IN the Greek this *Constellation* is called *Αίς Opvis*, i. e. *Aquila*, & *Jovis Ales*; it is likewise called in Arabick *Okab*, i. e. *Aquila Nigra*; by *Gesner* called *Leporaria*, which in the Persian Tongue is called *Aluk*; in Turkish, *Taushangjil*, i. e. *Aquila Leporaria*; in Hebrew it is called *Nescher*.

Nescher, which signifies an *Eagle*: It consists of 9 Stars, of which the third is called by the Arabs *al Nes'r al Tair*, i. e. *Vultur volens*; it is also called *Lucida Aquila*; the 9th Star is called *Danab Alakab*, i. e. *Cauda Aquila*. — This *Eagle* (according to the Poets) was Constellated by *Jupiter* for the Rape of *Ganymed*; or (according to *Aglaosthenes*) for that *Jupiter* going from *Naxos*, to War against the *Titans*, an *Eagle*, as he was Sacrificing, appeared to him in a happy Auspice; whereupon, after his *Victory*, he took that *Fowl* into his particular Patronage. But *Mero* gives us the *Fable* quite otherwise; for he Writes that the *Eagle* was Constellated by *Jupiter*, for suckling him when an Infant in *Creet*, with *Nectar*, which the first Drank from a Rock, and then brought it to the God. About the middle of *July*, at Midnight it may be seen on the Meridian.

The D O L P H I N.

BY the Greek it is called *Δελφίνος Ασείριος*, i. e. *Asterismus Delphinis*; by others *ἰσὶς ἰχθύς*, i. e. *Pisces Sacer*; in Hebrew *Dagaim*, i. e. *Pisces Maris*; the Arabs call it *Dulphin*; in which the most Eminent Star is one in the Tail, called by the Arabs *Danab al Dulphin*, i. e. *Cauda Delphinis*. This *Asterism* is by *Cicero* called *Carrus*; and by *Pliny Hermippus*, and by some others *Rhomboides*. This *Constellation* is famous for the Number of Stars in it being equal to the Number of the *Muses*; and also Famous; *Quod fuit Occultis felix in amoribus Index*; as being Instrumental to *Neptune* in his Amorous pursuit of *Amphitrite*, who fled, and conceal'd her self from him: Not is this *Asterism* less Signal for the Fabulous Transport of *Arian*, in *Ovid. Fast. l. 2*. It passes towards the Meridian at Midnight about the end of *July*.

P E G A S U S.

THIS *Constellation* is called *Pegasus*; by the Greeks, *Ἡρόδος ἵππος*, It is called likewise *Equus Major*, *Meduseus*, *Gorgonias*, *Bellerophonis* and *Menalippe*; by the Arabs *al Pharas Adam*, i. e. *Equus Major*, and *Alphabas al Thani*, i. e. *Equus Secundus*; in Hebrew it is call'd *Hafus chail Kerzim*, i. e. *Equus Cornutus*: It consists of 20 Stars; amongst which the chief, by the Arabs called *Sirra al Pharas*, i. e. *Umbilicus Equi*: That in the joyning of the Wing is called *Marchab*, i. e. *Equitandi vel vebendi Locus*, *Sigma*, *Ephippium*. Some Fable this to be *Bellerophons*, others *Perseus* his Horse: *Callimachus* and *Catullus* call him *Unigeniam Memnonis*; Brother to *Memnon* and Son of *Aurora*: The Greek Commentators make him to have been presented to *Aurora* by *Jupiter*: But *Lycophron* describes him to be the *Winged Steed* of the *Morning*, upon which he is said to *Ride*. *Palapharus* and *Artemidorus* make *Pegasus* to be a *Ship* and not a *Horse*: And according to *Vassus*, the Name *Pegasus* seems to be derived a *πῆγος* i. e. *compingo*, quia *Navis e multis componitur lignis*. It is seen in the Meridian at Midnight about the middle of *August*, and beginning of *September*.

ANDRO:

A N D R O M E D A.

THis *Asterism* is called by the Arabs *al Mara al Mofalsala*, i. e. *Mulier Catenata*; In Hebrew *Isha Shalahajala Baal*, i. e. *Fœmina carens virò*. It consists of 27 Stars; among which the 12th called by the Arabs *Gicmb al Mofalsala*, i. e. *Latus Catenata*; that in her *Girdle* is called *Izar* and *Mizar*; that in the *Border* of her *Vest* they call *al Deil*, vel *Addeil*, i. e. *Syrma seu Lacinia Vestis*; the 15th is called *Rigif al Mofalsala*, i. e. *Pes Catenata*. This Constellation comes to the Meridian about the middle of *October*. Asto the Fable of *Andromeda*, see after in the *Whale*.

P E R S E U S.

THis Constellation is by the Arabs called *Cheleub* or *Chelub*, i. e. *Dceptor*; and from the Greek Name *Perseus*, *Bershaush* and *Bersheush*; it is likewise called by them *Himel Ras al Ghul*, i. e. *Portans caput Larva*: It consists of 29 Stars; of which 3 inform. The first is called *Misam al Thuraiya*, i. e. *Carpus Pleiadum*, and *al Gicmb Bershaush*, i. e. *Latus Persei*; the 12th is called *Ras al Ghul*, i. e. *Caput Larva*; by the Jews, *Rosh ha Sathan*, i. e. *Caput Diaboli*, the 24th called *Menkih al Thuraiya*, i. e. *Interscapillum Pleiadum*. This *Perseus* was the Grand Child of *Acrisius* King of the *Argives* begotten by *Jupiter* on his Daughter *Danae*, placed in Heaven by favour of *Minerva*, for having slain *Medusa* or the *Gorgon*, and freed *Andromeda* from the devouring *Sea Monster*. This *Asterism* is on the Meridian at *Midnight* in the Month of *November*.

D E L T A O T O N.

Called also *Trigones* and *Delta*; by the Latines *Triangulum*, and *Nilus Donum*; by the Arabs; *Mothallath*, i. e. *Triangulum*; in Hebrew, *Himmofclush*, i. e. *Tripartius*. It consists of four Stars, that in the top of the Triangle is called in Arabick, *Ras Almothallath*, i. e. *Caput Trianguli*. This Constellation is said to have been placed in Heaven by *Mercury*, in Memorial of the first Letter of *Jupiter's* Name, Δ *ibz*, *Bassus* in *Germanicam*, and *Hyginus* Write, that *Mercury* at the Command of *Jupiter*, placed it over the Head of *Aries*, as a Mark the better to discern that Sign of it self.

— *Obscuro lumine labens.*

As *Cicero* in *Aratæ*s. Others will have it to be the Figure of that part of *Ægypti* Constellated, which *Nilus* after that manner encompasses. This *Asterism* at *Midnight* comes to the Meridian in *October*.

C E P H E U S.

C E P H E U S.

THE true Name of this Asterism by the Arabs is *Keâphus*; In Hebrew it is called *Baalath Hala*, i. e. *Domina Flammæ*; and in Arabick *Multabab*, i. e. *Inflammatas*. This Constellation consists of 13 Stars, whereof two inform: Among which there is one in the Foot called *Al Rai*, i. e. *Pastor*; and between his Feet another called *Al Kelb*, i. e. *Canis*; and upon his Hands certain others called *Al Agh'nâm*, i. e. *Pecudes*. The 3d, 4th and 5th; are by *Ulugh Beigh* called *Cawakih al Pbir*, i. e. *Stella Gregis*.—This *Cepheus* was Son of *Belus*, by *Anchinoe* the Daughter of *Nilus*, from whence the Persians were heretofore called *Kupdras*, over whom he was King, as likewise of *Phœnicia*, and Reigned both in *Babylon* and *Joppa*, reckoned among the Royal Fautors of Astronomy. It is beheld in the Meridian at Midnight about the end of *August*, and beginning of *September*.

C A S S I O P E A.

IT is likewise called by the Greeks *ἡ ἄστρον*, i. e. *Mulier sedis, sive Throni*; by the Arabs *Dât al Cursa*, i. e. *Inthronata*. It is also known by the Latin Name of *Cathedra, Thronus & sedes Regia*; it consists of 13 Stars according to *Ptolomy*, but *Tycho* hath observed therein no less than 45, besides the *New Star* which appear'd in the Year 1573, and vanished the Year following: It is resembled by *Aratus* to the form of a *Laconian* or a *Carian Key*.—The first Star in this Constellation is by the Arabs called *Caph al Chadib*, i. e. *Manus vincæ*. The second Star is called by the Name of the whole Constellation; *Dât al Cursa*. The fifth is called *Ruchba Dât al Cursa*, i. e. *Genu Inthronata*. The bright one in the Breast is called *Sadr*, i. e. *Pectus*. This *Cassiopea* was the Wife of *Cepheus*, and Mother of *Andromeda*, who contending for Beauty with the *Nereides*, was, as a Punishment, and in Memorial of her Arrogance, placed in Heaven with her Heels upwards. But *Tycho* gives us a better ground of the Fable, who writes, That *Cepheus* was a great Astronomer, or, at least, a Favourer of the Professors of that Science, who in a grateful acknowledgment of his Encouragement of their Studies, gave to several Constellations the Name of his *Wife, Daughter, and Son-in-Law*, which he received from *Cicero*. He likewise reports, That in the time of *Cepheus*, those Stars which make the Constellation of *Cassiopea* did rise with the first degree of *Aries*; and that under that Constellation the *Æthiopeans* did solemnize the Inauguration of their succeeding Kings, in Memorial of their first Mother *Cassiopea*, whom he supposes more probably to have been called *Cassiopea*. This Asterism is discovered in the Meridian, partly in the end of *March* and beginning of *May*; partly at the end of *September* and beginning of *October*.

R E C R E A T I O N S

C A P U T A L G O L :

O R,

M E D U S A ' S H E A D.

THE Fable concerning this Constellation is this. *Perseus* coming into Mans Estate, and being furnished with Sword, Hat and Wings, of his Brother *Mercury*, was sent by his Foster Father *Polydeutes* to kill the Monster *Medusa*, who was to have devoured *Andromeda*, who for the Pride of her Mother *Cassiopea*, was bound with a Chain to a Rock by the Sea side for that purpose; but *Perseus* pitying her case, undertook to fight with the Monster upon condition that *Andromeda* might be his Wife: Whereupon he slew the Monster, and Delivered and Married *Andromeda*, and returned home to the Isle of *Seriphus* with the *Gorgons* Head. For which Exploit, *Jupiter* his Father took him up into Heaven, and there placed him in the form he overcame *Medusa*, with his Sword in one Hand, the Head of *Medusa* in the other, and the Wings of *Mercury* at his Heels. *Schillerius* attributes it to *St. Paul*; *Shickardus* to *David* with the Head of *Goliath*.

H E N I O C H U S.

THis by the Greeks is called Ἰππολαμῖς, Ἐλάσπις, Ἀριμλάμῖς, ἢ Διφρηλάμῖς; by the Jews *Ha Roah scobido Haresan*, i. e. *Pastor tenens frenum*; and in the same sense by the Arabs, *Masik al Inan*, i. e. *Tenens Habenam*, or *Mumfik al Amna*, i. e. *Tenens Habenas*, to which the Greek Name *Heniochus* answers, i. e. *Habenifer*.—It consists of 14 Stars, among which the 4th is called *Menkib Dil Inan*, i. e. *Humerus Heniochi*: The 11th *Ca'b Dil Inan*, i. e. *Talus Henioce*.—This Constellation the Scholiasts of *Germanicus* will have to be *Mirtillus*: The *Trezenians* are for *Hippolitus*; others for *Erichthonius*, who *Pliny* makes the first that join'd Four Horses in a Chariot. *Eusebius* makes *Trochilus* the *Argive*, who was the Son of *Callithea* the Priestess of *Juno*, the first Inventa thereof: Others will have him to be *Oenomaus*. This Sign attains the Meridian at Midnight about the middle of *December*.

H Æ D I, or the K I D S.

THese are two Stars in the Left Arm of *Heniochus*, called by the Arabs *Sadateni*, i. e. *Brachium sequentis*. They are likewise called *Giedyan*, and *Maazein*, i. e. *Duo Capri*. These *Cleostratus* the *Tenedian* is said first to have discovered: They are said both at their Rising

A S T R O N O M I C A L.

51

Rising and Setting to cause Storms and Tempests, and therefore by the Poets called *Horrida & insana Sydera*.

The A M A T H E A N G O A T.

THis is a bright Star in the Shoulder of *Hemiochus*, of the first Magnitude, called by the Arabs *Aiyuk*, and commonly, instead thereof, *Atud*. In Hebrew, *Alh* or *Aish*; in Syriack *Jyutho*; all signifying *Capellum*. This the Poets Fable to have been the Mother of the two *Kids*, and Nurse to *Jupiter*; tho others report him to have been Suckled by a *Sow*; the *Cretans*, for that cause, honouring that Creature as Sacred. But the more General Opinion is, That he was Suckled by a Goat, and from thence he deriv'd the Title of *Agiochus*, or the *Goat-Nurs*. And to this effect, in some Medals of the Emperor *Valerianus*, he is represented in the Figure of a Child mounted on the back of a Goat, with this Inscription, *J O V I C R E S C E N T I*. I shall hereunto only apply an Ingenious Epigram of *Crinagoras*, in Greek, upon a Goat, whose Milk *Augustus Caesar* used to Drink.

Thus Englished:

*When Caesar did our full Bags Nectar taste,
Whose Spring th'Exhausting Pate could never taste;
Me, that he might not want that Milky store,
To sea, with him, in his own Ship he bore.
Streight 'mong the Stars, shall I be made to shine,
For he I serve, than Jove's, no less Divine.*

P L E I A D E S and H Y A D E S.

SEven Stars on the back of the *Bull*, by the Latines, from the time of their Rising, called *Vergilia*; by the Greeks *ἑπτὰ πλῆν*; by the Arabs *Al Thuraiya*, i. e. *Multus seu Copiosus*. They are likewise by them called *Al Negim*, i. e. *Astrum*; by the Syrians they are called *Chimo*; by the Persians *Peru*, and *Peruia*; by the Turks *Ulger*; by the Jews *Chima*, and *Succoth Benoth*. These are said to have been the Daughters of *Atlas* and *Pleione*, whom *Mero* makes the Nurse of *Jupiter*, who fed him with *Ambrosia*; but commonly they are reputed the Nurses of *Bacchus*, and for that Constellated. Their Names are *Mais*, *Sterope*, *Taygeta*, *Celso*, *Electra*, *Merope*; or, according to the Scholiast of *Theocr. Coacymo*, *Glaucia*, *Proxis*, *Parthenia*, *Mais*, *Stomychia*, *Lampado*. *Michael Florentius* adds to them two other Stars, which he calls *Atlas* and *Pleione*. *Galileus* hath observed in this Constellation above 40 Stars; and *Ricciolus* no less than 40.

The seven Stars in the Head of the *Bull*, called by the Greeks *Pleiades*, the Latines call *Suconle*, from the Greek Letter τ *Upsilon*, which they resemble, or from their Mother *Hya*, Daughter of *Oceanus*, and Wife of *Atlas*; by *Ulugh Beigh* they are called *Al Debarân*,

R E C R E A T I O N S

however that Name is peculiarly applied to the brightest of them, commonly called *Oculus Tauri*; in Hebrew they are called *Chima*, from the number of Stars of which they consist. These excessively lamenting the Death of their Brother *Hyas*, who in Hunting was slain by a Lion, were, by the commiserating Gods, converted into Stars, whose Names are *Ambrosia*, *Eudora* (or *Eudoxa*) *Pheile*, (or *Pasthea*) *Phileto*, (or *Pytho*) *Thyene*, (or *Take*) *Coronis* and *Prolixo* (or *Plexauris*.)

III. Of the Ancient Southern CONSTELLATIONS.

O R I O N.

THis Constellation was first by the *Berians* called *Candaon*, afterwards *Ὠκεύωρ*, called by the Latines *Hyriades* and *Hyrides*, from his Father *Hyries*. It is by *Plautus*, *Festus* and *Varro*, called *Jugula*, *eo quod armatus sit ut Gladius*; by the Jews it is called *Gibbor*, i. e. *Gigas*, and *Kelb Ha Gibbor*, i. e. *Canis fortis*, and *Bellator Fortis*; by the Arabs *Al Gianza*, and also *Al Gibbar*, i. e. *Gigas fortis*; in Syriack it is called *Gavoro*; in Caldie *Niphla*. It consists of 38 Stars, amongst which the first is called *Hecka*, i. e. *a white Circle*; by which Name the 3 Stars in the Head are denominated. The second is called *Mengkib al Gianza*, i. e. *Humerus Orionis*; and *Jed al Gianza al Jumma*, i. e. *Mannus dextra Orionis*. The 3d is called *Mirzam al Nagiid*, i. e. *Leo Strenuus*. The 17th and 25th are in the Arabick called *Al Tagis*, and *Al Dawâib*, the first signifying *Tiara*, the other *Antie seu Lemnisci*. The 26th, 27th and 28th, are called *Mintaka al Gianza*, and *Nitak al Gianza*, i. e. *Cingulum seu Baltheus Orionis*. The 29th, 30th, 31 and 32, are called *Saiph al Gibbar*, i. e. *Emphs Gigantis*. The 35th is called *Rigil al Gianza al Jusra*, i. e. *Pes Gigantis Sinister*; and *Rai al Gianza*, i. e. *Pastor Orionis*. The 38th is called *Rigil al Jumma*, i. e. *Pes Dexter*. — The Fable of this Constellation is by some thus related: *Orion* being a great Companion of *Diana's* in her Hunting Diversions, *Apollo* grew Jealous of his too much familiarity with his Sister, and to be Revenged, seeing *Orion* one day swimming in the Sea, his Head appearing above the Water like a black Mark, he shew'd it to his Sister, and told her she could not hit it; whereupon, she presently drawing her Bow, let fly, and kill'd him, not knowing who he was, till the Sea had cast him on the Shore; which perceiving, and much troubled, to make amends, she plac'd him in Heaven near the *Dog* and the *Hare*, where he seems still to Hunt. The Persians will have this Asterism to represent *Nimrod*. It is seen in the Meridian at Midnight in the Month of *December*.

SIRIUS, or the GREAT DOG.

THis is Fabled to be *Orion's Dog*, Named *Lalaps*; others make it *Ifis* her Dog: Some again make it *Cephalus's*. By *Ovid* it is called *Canis Icarus* and *Erigonus*. By the Greeks *Κυνος Ἀστεισμός*, i. e. *Canis Asterismus*. By the Latines it is called *Canicula*; the Ancient Egyptians believed this Constellation to be the Soul of *Ifis*. *Germanicus* and *Hyginus* give it the Name of *Mora*; the Ethiopians give it to *Nilus*, as if it were *Sydus Niloticum*, by reason of the great affinity between *Nilus* and that Star, for in the Dog-Days, that River hath its greatest Inundation. By the Arabs it is called *Kelb Acbur*, i. e. *Canis Major*; by the Syrians *Kelbo Gavoro*, i. e. *Canis Gigantis*; by the Egyptians it was called *Sorhis*, in Memory of a King of that Name, Father to *Rhameses*, who was a great Erecter of Obelisks, and Restorer of the Egyptian Learning. This Constellation contains 29 Stars, whereof 11 inform: It is seen in the Meridian at Midnight about the end of *December*.

LEPUS the HARE.

THis Constellation is by the Greeks called *λεπυς, ἢ λίπυς*; by the Latines *Lepus*. The Arabs call it *Arneb*; and the Jews *Arnebeth*, i. e. *Lepus*. It consists of 12 Stars, whereof the 7th, 8th, 9th and 10th, are called in Arabick *Arsh al Gianza*, i. e. *Solum Orionis*. Some will have this placed in Heaven in Memorial of the Chase affected by *Diana* and *Orion*; Others make *Mercury* the Author of this Constellation, in Testimony of the fruitfulness and pregnancy of this Creature. *Hyginus* and *Bassus* write, That Anciently in the Island *Hiero* there was no Hares, until one of the Islanders brought thither from beyond the Seas a Female big with Young; and that from thence, in a short time, they increased, and grew so numerous, as wanting sufficient Food, they destroy'd all the Crop in the Island, and brought a Famine upon the Place. In Memorial of which, this Asterism was Figured in the Heavens.—To this purpose there is an Ingenious Epigram of *Cesar Germanicus* in Greek.

Thus Englished.

*A Hare by Hounds pursu'd, them having scap'd
Met on the shore a Dog-fish, and was snap'd:
Then cries, 'Us Earth and Seas are bent r'undo,
Heaven's only left; yet there is a Dog too.*

This Constellation is seen in the Meridian at Midnight in the Month of *December*.

PROCYON,

R E C R E A T I O N S

P R O C Y O N, or the L I T T L E D O G.

Called likewise *Canis Minor*; *Procyonis* and *Præcanis*; but *Cicero* and *Ausonius*, *Anticanis*. *Pliny* says that the Romans had no Name for it, unless *Canicolum*. By the Arabs it is called *Kelb Afgher*, i. e. *Canis Minor*; it is likewise by them called *Sbirâ al Shamija*, i. e. *Syrius Shamensis*. The Arabs make the greater and lesser *Dogs* to be the Sisters of *Canopus*; but the Poets Fable this *Little Dog* to have been *Erigone's Dog*, who mourned to Death for the loss of his Mistress, who Hanged her self for Grief that her Father *Icorus* was slain by his Drunken Peasants. This Constellation consists only of two Stars, as *Ptolomy*, of which, that in his Shoulder is by the Arabs called *Al Mirzam*, and *Al Dira al Mesbura*, i. e. *Brachium expansum*; the other at the Root of the Tail they call *Al Shira*, *Al Shamija*, i. e. *Syrius Shamensis*, and *Al Ghomeisa*. It is seen in the Meridian in the Month of *January* at Midnight.

A R G O, N A V I S.

This Constellation is by *Ptolomy* called *Ἀργὸς Ἀστεισμός*, and by some simply *Navis*, i. e. *Navis*; by the Arabs *Mercab*, i. e. *Currus seu vehiculum*; for so, by the Poets, the Ship *Argo*, which this Asterism represents, is called *Currus volitans*. It is likewise in Arabick called *Al Scybina*, i. e. *Navis*. It consists, according to *Ptolomy*, of 45 Stars; by *Sagerus* of 63; and by *Kepler* of 53. There are several Stars of second Magnitude not far from it, which by the Arabs are called *Sobeil Telkin vel Belkin*; or (as Mr. *Hide* reads it) *Belkis*, that being the Name of the Queen of *Sheba* that came to visit *Solomon*. The Poets feign this to be the Ship wherein *Jason* did fetch the *Golden Fleece* from *Colchis*; some will have it to be the *Ark of Noah*. *Navidius* saith it is the Ship wherein the Apostles were when Christ appeared unto them walking on the Sea. The Poets do generally agree that this Ship was the first that ever Sail'd the Seas, but *Diodorus Siculus* plainly affirms the contrary, for speaking of *Jason*, he says that he first, under the Mountain *Pelias*, built a Ship of far greater bulk than any that were then us'd, for at that time Men only Sail'd in small Barks or Skiffs; so that this *Argo* seems not to be the first Ship, but rather the first of its kind. This Ship arrives to the Meridian at Midnight about the end of *January*.

D R A C O.

D R A G O.

THis Serpent is by *Ptolomy* called Ἰδρυ Ἀστρονός, i. e. *Hydri Asterifmus*; by the Greeks it is called Ἀσδία, and by the Arabs *Albugia*, i. e. *Serpens tenuis*. *Ricciolus* says it is in Arabick called *El Hawick*; and *Kepler*, *Aphaak*; in Hebrew *Hajah*, i. e. *Serpens*. In this Constellation there are 32 Stars, 7 inform, whereof the first Star is called *Minchir al Shugja*, and the others, from that to the seventh, inclusive, *Min al Azal*, i. e. *Ex Inermi*, as if appertaining to the Sign *Virgo*. The 12th Star called by the Latines *Cor Hydrae*, is in the Persian Tables called Ἰδρυ Ἀυξ, and accordingly in *Ulugh Beigh*, *Unuk al Shugja*, *Collum Serpentis*; and *Pherd al Shugja*, i. e. *Solitaria Hydri*. The Head of this Constellation is seen in the Meridian at Midnight about the beginning of *February*; its Middle about *Mid-March*; and its Tail in the beginning of *April*.

C O R V U S the C R O W.

THis by the Greeks is called Κασκός Κβραχός, i. e. *Corvus*, & *Corvi Asterifmus*; by the Jews it is called *Oreu*, and from thence by the Arabs *Al Gorab*, *Corvus*. It is likewise by them called *Al Ghiba*, i. e. *Tentorium*; and *Arsh al Simak*, i. e. *Solium efferentis* (*Scil. intermem vel Verginem*) and *Agiar al Asad*, i. e. *Clunes Leonis*; and *Al Agimal*, i. e. *Cameli*: It is seated upon the Tail of the Serpent, and consists of 7 Stars, of which the first is called in Arabick *Minkar al Gorab*, i. e. *Rostrum Corvi*; the fourth *Gienah al Goras al Siman*, i. e. *Ala dextra Corvi*. The Fable of this Constellation is thus: The Crow being sent by *Apollo* to fetch Water for a Libation, seeing a Fig-Tree full of Figs, but not Ripe, made stay there until the Figs were come to maturity (which Fable seems to be derived, says *Bochart*, from *Noah's* sending the Crow out of the Ark) and having satisfy'd his longing, went to the Fountain to fetch Water, but coming thither meets with the Serpent before-mentioned, whereat affrighted, he returns back with the empty Pitcher, telling *Apollo* there was no Water in the Fountain. This untruth being discovered by *Apollo*, he Prohibited the Crow for ever Drinking at that time of the Year, and in Memorial of the Fact, plac'd the Crow, Snake and Pitcher, in the Heavens. The Crow is Sacred to *Apollo*, the President of Divination; forasmuch as this Fowl, by its different Notes, is said to foretel Fair and Foul Weather; or for that *Apollo*, fearing the pursuit of *Typhon*, is said to have assum'd the Figure of that Fowl; or in allusion to the Sun's departure, causing darkness and Night of the same Colour with the Crow, as his return does the Day or Light, resembling the whiteness of the Swan, which is likewise Sacred to that God. This Asterism is seen in the Meridian at Midnight about the middle of *March*.

The

The C U P .

M*Abilius* appropriates this Cup to *Bacchus*; *Aratus Hyginus*, and *Bassus*, to *Apollo*, according to the foregoing Fable. It is called by *Ptolomy* *Kαζαμπ* & *Ασεισις*, by others, *Hydria*, *Calpe*, *Cratera*, *Patera*, *Urna* & *Vas*; by the Arabs, *Batyra*, i. e. *Poculum Magnum*; by some it is called *Alkis*, i. e. *Cyathus*, from the Hebrew *Kus* or *Kos*, signifying the same. It consists according to *Kepler* of Eight Stars, which by the Arabs are called *al Mālah*, i. e. *Præsepe*: It is apparent in the Meridian at Midnight, about the middle of *March*.

C E N T A U R E .

Some will have this to be *Minotaur*; others *Chyron*, the Son of *Saturn*, and *Phillyra* the Daughter of *Oceanus*, who taught *Æsculapius* Physick; *Achilles* Musick, and *Hercules* Astronomy; with one of whose Poysonous Arrows, casually falling out of his Quiver, he was Wounded in the Foot; and of that Wound died, and by commiserating *Jupiter* was made a Sign in Heaven; called by *Ptolomy* *Κενταυρος* & *Ασεισις*. The Arabs making use of the Greek Name, by whom yet, according to *Ricciolus* it is called *Albeze*, and *Asmeat*; by the Greeks *κνις*; and in Barbarous Greek *Taraopoz*: It consists, as *Ptolomy*, of 37 Stars; all which, together with those that make up the *Fera Centauri*, are by the Arabs called promiscuously *Alshamarich*, i. e. *Spadices*, bright dappled: The 35 Star is, by *Valugh Beigh*, called *Rigil Kentaurus*, i. e. *Pes Centauri*. This Constellation passes the Meridian at Midnight at the end of *April*.

The A L T A R .

Called by the Greeks *θυσιαστηριον*, *πυραμυρον* & *θιασος*, by the Latines *Thuribulum*, *Conceptaculum*, *Bathilius*, *Sacrarium*, *Putcus*, *Templum*, *Lar*, *Acerra*, *Ara*, & *Altare*; by the Arabs, *Almeagramet* or *al Mugramrah*. It consists of 7 Stars, This was the first Altar (according to the Poets) that was ever Erected: It was Fram'd by the *Cyclops*, and in Memorial of the Fact Constellated. *Lactantius* Reports, that the first Altar that *Jupiter* Erected, was in Honour to *Cælus*: But the Deities to whom *Jupiter* Sacrificed upon this Expedition against the Giants, we find (from *Diodorus Siculus*) to have been the Sun, Heaven, and the Earth. This Constellation comes to the Meridian at Midnight about the End of *June*.

The

The WHALE.

THIS Asterism is by the Greeks called *Κητος, πηστις ἢ Ορπος*, by the Latines, *Cete* and *Cetus*, *Balea*, *Pistrix*, *Leo*, or *Ursus Marinus*; By the Arabs *Alketus*: *Ptolomy* reckons in it 22 Stars; and *Kepler* 25; of which, the Bright one in the Snout of the Whale is called *Menkar Alketus*, i. e. *Rostrium Ceti*: That in the Tail, *Danab Alketus*, i. e. *Cauda Ceti*; and both these by the Arabs are called *al Diphdaan*, i. e. *due Rana*: There are two also in the Hands (for this Fish is conceived to be the same with *Dagon*, or *Derceto* the Syrian Idol, which was represented in the Upper part after a humane shape, in the lower, after that of a Fish; and by the Jews Named *Adir Dag*, i. e. *Piscis Magnus*: They are by the Arabs called *al Naaman* or *al Naamat*, i. e. *Struthio Cameli*: The second Star in this Constellation is called *Caph al Giedma*, i. e. *Manus Truncata*: The 21 Star is called *Danab al Ketus Shemali*, i. e. *Ceti Cauda Borealis*: The 22th *Danab al Giembi*, i. e. *Cauda Australis*; and *al Diphda al Tha'ni*, i. e. *Rana Secunda*: This Constellation is seen in the Meridian at Midnight, from the beginning of *October* to the end of *December*.

The Southern P I S H.

THE Poets Fable this to have been the Fish which saved *Phacis*, or *Aphacis*, the Daughter of *Venus* fallen into the Lake *Boeth*; and for that Reason Constellated; by the Arabs called *al Haut*, *al Giembi*, i. e. *Piscis Australis*: *Hyginus* calls it, *Piscis Solitarius*; and *Bassus*, *Piscis Magnus*: And it is said to have Spawned the other two in the Zodiack: It consists of 12 Stars, amongst which the Bright one in the Mouth is called *al Diphda al Awwal*, i. e. *Rana Prima*, and *al Dalim*, i. e. *Agger*; and *Phom al Hont*, i. e. *Os Piscis*; and commonly (but erroneously) *Phomahant*: It is seen in the Meridian at Midnight about the middle of *August*.

ERIDANUS, or PADUS.

IT is a Southern Asterism, which some will have to be made a Constellation in Memory of *Phaeton*, who was Drowned therein; the Egyptians Challenge it for their *Nilus*: It is called by the Greeks *ποταμός Ορίωνος*, i. e. *Fluvius Orionis*; because it springs from the Left Foot of *Orion*, and runs from thence in a fluxious Course Southward: It is likewise called *Gybon*, and *Vardi*, i. e. *Fluvius*; by the Moors *Gnad*; and by the Arabs *Nahr*: The Thuscans call it *Botignon*; the Ligurians, *Botigum*. It consists of 34 Stars, of which that of the first Magnitude is by the Arabs called *al Dalim*, i. e. *Agger*; it is likewise called in Arabick *Ather Nahr*, i. e. *Ultima Fluminis*; whence the common Name *Atarnar*: It is seen upon the Meridian at Midnight in *November*.

CORONA AUSTRALIS five NOTIA.

IT is called by the Greek Poets *Ῥότα Ἰξίωνος*, i. e. *Rota Ixionis*: The Arabs give it different Names, as *al Cubba*, i. e. *Testitudo vel Tabernaculum*; and *Az'ha al Naam*, i. e. *Nidus Struthionis*. This Constellation consists of 13 Stars. It is Fabled to be made a Constellation by *Bacchus*, in Honour and Remembrance of his Mother *Semele*. It comes to the Meridian at Midnight (but not visible in our Horizon) in the beginning of July.

IV. Of such other Constellations Northern and Southern, as have been Discovered by Modern ASTRONOMERS.

I. Modern Northern CONSTELLATIONS.

COMA BERENICES.

IT is by *Bayerus* called *κρόμμυς*, i. e. *Coma, Spicarum Manipulus*: The Arabs call it *Alhand*, i. e. *Lacus seu Cisterna*: It consists of 7 Stars. The Original of this Constellation was from *Berenice*, the Wife of *Ptolemaeus Energetes*, who Vowed, if her Husband returned Victorious from his *Asian Expedition*, she would shave her Head and Offer her Hair to *Venus* to be hung up in her Temple; which being accordingly performed; it was, the next day after the Offering thereof, found missing; whereupon *Conon*, to flatter King *Ptolomy*, discovered to him, that the Head of Hair was Translated to Heaven, and made a Celestial Constellation.

ANTINOUS and GANIMED.

THESE are one and the same Constellation; for the Asterism which by the Greeks is feigned to represent *Ganymed* Rap'd by the *Eagle*, and carried up to Heaven to serve *Jupiter* as a Cup-Bearer; the Romans in Honour to *Antinous* (the beloved Favorite of *Hadrian* the Emperour) will have to be the Representation of that Beautiful *Bythinian*, who dying a Voluntary Death for the Welfare of the Emperour, was by him Honoured with Statues, Temples, Priests, and a place among the Celestial Constellations; between the *Eagle* and *Sagittarius*. It consists of 7 Stars; and comes to the Meridian about the middle of July.

EQUU:

EQUULEUS.

THis Asterism, called also the Lesser Horse; is by *Ptolemy* called ἵππος ἄσπερος, *Asperus* by others πικρὸν ἵππου, i. e. *Scythio Equi*; In *Chryso-cocca's* Tables κεφαλή ἵππου, i. e. *Caput Equi*; by *Mugh Beigh*, *Kit'a al Pharas*, i. e. *Scythio, Præcisio, vel, Segmentum Equi*; but by others of the Arabs called *al Pharas al Annal*, i. e. *Equus Primus*; it consists of four Stars in form of a Horse's Head and Neck: It comes to the Meridian at Midnight at the beginning of *August*.

¶ To these Northern Constellations some late Astronomers have added several other Asterisms, composed out of the Inform-Stars: As of those between the *Greater Bear* and the Sign *Leo*; they have formed the River *Jordan*—Of those between the North-Pole, *Perseus* and *Auriga*, an Asterism called *Camelo Pardalis* and *Gyrassa*.—Of the four Stars interposed between the Triangle and Tail of the *Ram*, another called *Vespa*; by some *Apes*; i. e. the *Wasp* or the *Bees*.—Of the Tract of Stars Running between the *Swan* and the *Eagle*, as far as *Serpentarius*, they have formed the River *Tigris* or *Euphrates*.—And to a single Star of the second Magnitude, placed in the middle between *Charles his Wain* and *Coma Berenices* (from which if a Right Line be drawn through the first Star in the Tail of *Ursa Major*, towards the Pole, it will point directly to the *Pole Star*) they have given in Memory of the most Glorious Prince and Martyr *CHARLES* the I. King of *England*, the Name of *Cor Caroli*. The Primary Invention and Denomination thereof being owing to the most Loyal and Learned Sir *Charles Scarborough*, my most Honoured Friend.

II. Modern Southern CONSTELLATIONS:

MONICERUS or UNICORN.

IT is placed between *Orion* the *Great Dog*, and *Hydra*.

ALECTOR vel GALLUS.

OR the *Cock*, between the *Great Dog*, and the Ship *Argo*.

R E C R E A T I O N S

C O L U M B A.

OR the *Dove* of *Noah*, with an *Olive Branch* in her *Beak*, not far from the *Great Dog*.

G R U S or the C R A N E.

IT consisteth of 13 Stars, whereof Three of the Second Magnitude; one in the *Head*, one in the *Tail* or *Train*; and another in the Southern Wing. This Asterism is also called *Phenicopterus* and *Genaros*; and it is seated under the Southern *Fish*.

P H O E N I X.

ON her *Spiry Pyre*, consisting of Fifteen Stars; among which there is one in the *Neck* thereof of the Second Magnitude, and two *Nebulous*; It is seated between the Southern *Fish* and *Eridanus*, under *Cauda Ceti*.

T O U C A N.

Otherwise called the *American Goose*: It is likewise called *Pica Baa flica*, *sea-Indica*, and *Ramphestes*: It consists of Eight Stars, whereof Four of the Second Magnitude. This Asterism is placed in the midst between the *Phenix* and *Indus*.

I N D U S.

OR the *Indiar*, in the Figure of an *Indian*, holding in either hand a *Dart*; and therefore likewise called *Sagittifer*: It consists of Twelve Stars, and is seated between *Toucan*, and the Constellation called *Pavo*.

P A V O.

P A V O.

THE *Peacock*; or, according to the Greek *ἰαδς*; consisting of Sixteen Stars; whereof, one in the *Head* thereof, is of the Second Magnitude, and two *Nebulons*: It is placed near to *Indus*, under *Sagittarius*.

A P O U S.

OR *Apis sive Avis Indica*; *Avis Paradisi*, & *Mann Codjata*; consisting of Twelve Stars: It follows after the *Peacock*, with its *Tail* toward the *Antartick* Pole.

A P I S.

CALLED also *Musca* or *Maia*; and *Crabo Indicus*; consisting of Four Stars, placed under the *Centaur*.

TRIANGULUM AUSTRALE.

T*Rigonium Notius, sive Deltoton*; to whom some likewise have given the Arabick Name of *Almutabet Algenubi*; consisting of Five Stars; in each Angle one of the Second Magnitude, and two others. It is seated *sub fera Centauri & Ara*, called by *Schillerus*, *Signum Tau*; *sive*, *Imago Crucis*; by the Spaniards, *El Cruziero*.

C A M Æ L E O N.

PLACED directly in Opposition to the *Lesser Bear*; and whose Form; (according to the disposition of the Stars which compose it) it represents: It consists of Ten Stars: It is placed directly under the Constellation *Musca* or the *Fly*.

P I S C I S.

R E C R E A T I O N S

P I S C I S V O L A N S.

Volucris, & Volatilis; called like wise *Passer Marinus*; and *Hirundo Marina*; in which last sence it is noted by a new Greek Name *Chelidon Thalassia*; It consists of seven Stars, seated under the Ship *Argo*, next to *Dorado*, or the *Sword-Fish*.

D O R A D O.

Piscis *Auratus* (as the Spaniards call it) *Chrysopterus*, or the *Golden Fish*; called likewise *Xiphias seu Gladius*, or the *Sword Fish*; It consists of 6 Stars, with which it Describes and Circumscribes the *Pole* of the *Ecliptick*.

H Y D R O S.

By the Dutch called the *Wasser Schlange*, consisting of 15 Stars; the last Star in the Tail whereof was in the Year 1600, distant 2 degs 30 min. from the Southern Pole; but at present (as *Ricciolus* Notes) at a nearer distance.

V. O F G A L A Z I A.

IT is that great *White Circle* which is seen in the Heavens in a cold Winters Night (and at other times also) and by the Greeks called *Galaxia*; by the Latins *Lactea Via*, or *Lacteus Circulus*; and in English the *Milk Way*.

Concerning this Circle there are sundry Opinions both of Philosophers and Poets, some of which I have here inserted.

The Philosopher *Democritus* affirms the cause of this Circle to be the exceeding great number of Stars in that part of the Heaven, whose Beams meeting together so confusedly, and not coming distinctly unto the Eye, causes us to imagine such a whiteness as is seen.

Others are of Opinion (and the more likely) That this *Milk way* is a part of the *Firmament*, neither so thin as the other parts thereof, nor yet so thick as the Stars themselves: If it were as thin as the other parts of the Heavens besides the Stars, then could it not retain the Light, but the Light would pass through it, and not be seen. If it were as thick as the Stars, then would the Light be so doubled in it, that it would glister and shine as the Stars themselves do: But being neither so thin as the one, nor so thick as the other, it becometh of that whiteness which we see it of.

The

The Poetical Fables concerning this Milky way are many.

Ovid saith it is the great Causey, and the High-way, that leadeth to the Palace of *Jupiter*.

Others say, *Jupiter* having begotten *Mercury* on *Maiâ* the Daughter of *Atlas*, brought the Child when he was BORN to the Breast of *Juno*; she lying asleep; but *Juno* awaking, threw the Child out of her Lap; and let the Milk run out of her Breasts in such abundance, that (spreading it self about the Heaven) it made that white Circle which we see.

Others say, that it was not *Mercury*, but *Hercules* which was laid in the Lap of *Juno*; for *Jupiter* knowing the great hatred that *Juno* bore to the Babe, perswaded himself, that if it were possible to get her to Nourish it, she could not but (as if it were by Nature) bear the Child good Will: Hereupon, *Hercules* was brought unto her Breasts as she lay asleep; *Juno* feeling him to draw very hard, awoke suddenly out of her Sleep; threw the Child out of her Lap, and let the Milk run down the Heaven; whereby it was Stained White.

Others say, That *Juno* did not let her Milk run out of her Breasts; but that *Hercules* Suck'd them so earnestly, that his Mouth ran over, and so this Circle was made.

Others say, That *Saturn* being desirous to devour his Children; his Wife *Ops* presented him with a Stone wrap'd in a Clout, instead of his Child. The Stone stuck so fast in *Saturns* Throat, as he would have swallowed it, that without doubt he had therewithal been Choaked, had he not been Relieved by his Wife, who by pressing the Milk out of her Breast saved his Life: The Milk that missed his Mouth fell on the Heaven, and running along made this Circle.

The End of the Astronomical Part.

The End of the Journey

RECREATIONS Horometrical.

CHAP. I.

How to make an Horizontal Dial for any Latitude, by help of a Line of Chords.

Horizontal Dials are such as are usually made on *Brass Plates*, and set upon the tops of Posts in Yards, Gardens, Windows, and other places.

A Line or Scale of *Chords* (by which this and other Dials are made) is such a Line or Scale as is described in *Geometrical Recreations*, Chap.V. Section II.

How to make an Horizontal Dial in any Latitude, by help of this Scale of Chords.

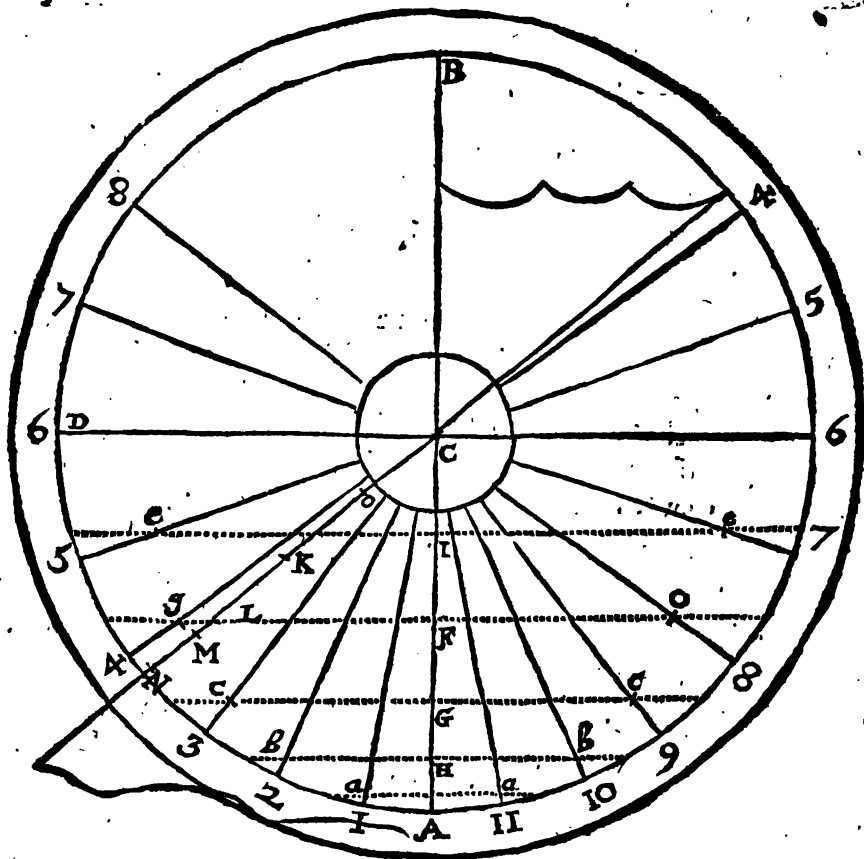

A

I. With

R E C R E A T I O N S

1. With 60 deg. of the *Chords*, upon the Center C, describe a Circle, and divide it into Four equal parts, by the Lines, B C, A for the *Meridian*, or Hour-Line of XII, and D E for the *Prime Vertical Circle*, or Hour-Line of VI.

2. If you would make your *Dial* for the Latitude of 50 degrees; take 50 deg. out of your *Scale of Chords*, and set that distance upon the Circle from A to N, and draw the Line C N, for the *Stile* or *Cock* of your *Dial*.

3. Divide the Two Quarters of your Circle, A E and A D, each of them, into six equal parts, so shall you have in each Quadrant five Points, by which you may draw five *Chord-Lines*, all Parallel to D E, the Line of six, which will cross the Line of Twelve C A, in the Points I, F, G, H and A.

4. Take one half of the Line A₂ and set it in the Line of the Stile C N, from C to O: From which Point O, take the nearest Extent unto the Line C A. This Distance set from A upon the same *Chord-Line* A, on both sides thereof, at *a* and *a*, through which Points *a* and *a* draw the Lines C *a* and C *a* for the *Hour-Lines* of XI and I of the Clock. In like manner,

Take half the $\left. \begin{matrix} H \\ G \\ F \\ I \end{matrix} \right\}$ *Chord-Line*, and set it $\left. \begin{matrix} K \\ L \\ M \\ N \end{matrix} \right\}$ from C to $\left. \begin{matrix} K \\ L \\ M \\ N \end{matrix} \right\}$ and $\left. \begin{matrix} K \\ L \\ M \\ N \end{matrix} \right\}$ take the nearest distance to $\left. \begin{matrix} H \\ G \\ F \\ I \end{matrix} \right\}$ C A, and set $\left. \begin{matrix} b \\ c \\ d \\ e \end{matrix} \right\}$ it from $\left. \begin{matrix} b \\ c \\ d \\ e \end{matrix} \right\}$

Which done (which may very speedily, and exactly be performed) draw Lines from the Center C through the respective Points *b b*, *c c*, *d d*, and *e e*, on both sides C A, and they shall be the true *Hour-Lines* belonging to an *Horizontal Dial*, for the Latitude of 50 Deg. that is, the *Hour-Lines* from six in the Morning till six at Night.

5. For the other Hours before and after six, as four and five in the Morning, and seven and eight at Night, they may be put in, by drawing the *Hour Lines* of four and five in the Afternoon, and seven and eight in the Forenoon, through the Center C, above the Line D E, as is evident by the Figure.

6. If you would insert the Halves and Quarters of Hours, you must then divide the Two Quadrants into 12 or 24 Equal Parts, and draw *Chord-Lines* through the *Meridian-Line* C A, and deal with them as you did with those for the whole Hours.

7. For the *Cock* or *Stile* of your *Dial*, it may be either a Plate of Brass cut into a Triangular Form, the Pattern whereof is the Triangle C S A, which must stand Square (or Perpendicular) upon the *Meridian-Line* C A. Or it may be a Rod of Iron bended to that form.

In Horizontal Dials observe these following N O T E S:

I. An *Horizontal Dial* in any Latitude, is an upright *South Dial* in that Latitude, which is equal to the Complement of that Latitude for which the *Horizontal Dial* was made—So the foregoing *Horizontal Dial* being made for the Latitude of 50 Deg. take 50 from 90, and there will remain 40; so that the former *Dial* will be a *Direct South Dial* in the

the Latitude of 40 Deg. And the Cock, or Stile, must point downwards towards the *South Pole*.

II. From an Erect Direct *South Dial*, an Erect Direct *North Dial* is deduced :—For, if you draw the *Hour-Lines* (*Stile* and all) of a *South Dial* through the Center, then will 12 at Noon on the *South* be 12 at Midnight in the *North*; and the *Cock*, or *Stile* of the *North Dial* must point upwards towards the *North Pole*; And the *Hour-Lines* about 12 at Night (*viz.* 9, 10, 11, 12, 13, 1, 2, 3.) must be omitted; As in *Fig. I.* all Three Dials are distinguished. So that a *North Dial* is no other than a *South Dial* inverted.

C H A P. II.

To make an Erect Direct East or West Dial.

These Dials are the same in all Latitudes, and may be made Geometrically, after this manner.

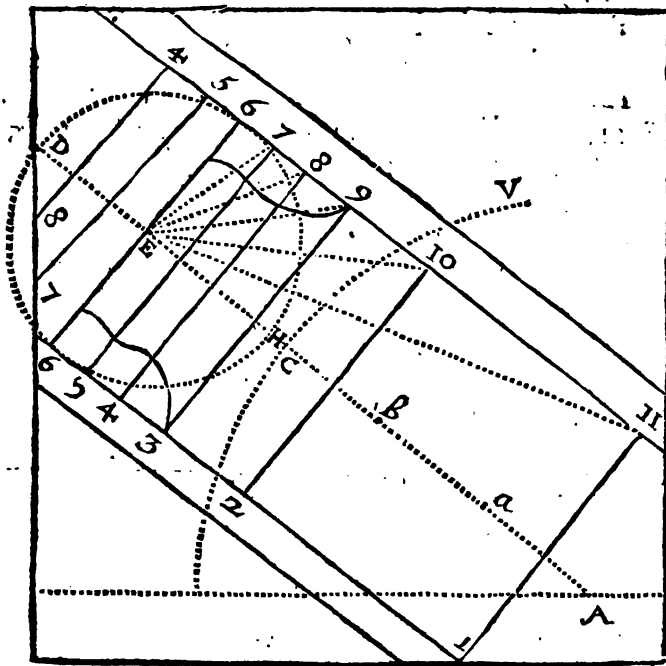

Towards the bottom of your Plain, draw an Horizontal Line B A ; At the *North end* thereof (as at A,) with 60 deg. of your *Scale of Chords*, describe an Arch of a Circle, as S C V. Then out of your *Scale of Chords* take the Complement of the *Latitude* (in this Example 40 deg.) and set them from S to C, and draw the Line A C D, quite through the Plain ; which Line D A divide into five equal parts in the Points a, b, H, E ; and with that distance of the *Compasses*, upon the Point

R E C R E A T I O N S

point E, describe the Circle D 6 H 6, and through the Center E, draw the Line 6 E 6, at right Angles to the Line A D, and that shall be the Hour Line of six; And by the Points 6 and 6 draw the Lines 6 11. and 6 1, both parallel to the *Equinoctial Line A D*----Then divide one Quarter of the Circle into six equal parts, and laying a Ruler upon the Center E, and each of those parts, it will cut the uppermost parallel Line in the points 6, 7, 8, 9, 10 and 11. From which points, if you draw Lines parallel to the Line 6 E 6, they shall be the Hour Lines of an *Errect Direct East Plain*. For the Hour-lines before 6 in the Morning and after 6 in the Evening, they are the same with those before 6 in the Morning, and before 6 in the Evening: For the distance betwixt 6 and 5, is the same as is between 6 and 7, and the distance between 6 and 4 the same as between 6 and 8----For the *Stile of these Dials*, it may be a Plate of Brass, so broad as is the distance between the Hour-lines of 6 and 9, and must be placed perpendicularly upon the Hour-line of six. This Plain hath Two Faces, one open to the *East* (as this in the Figure) the other to the *West*; and one being made the other is made also: For, if you prick (or draw) the Lines of the *East Dial* through the Paper, those Lines on the back side shall be a *West Dial*, only the *East Dial* Lines are those of the *Morning* from 4 till 11, and those of the *West Dial* are those of the *Afternoon* from 1 to 8 at Night.

From an East or West Dial, a Polar Dial may be deduced.

Suppose the Line A D in the *East Dial* to lie upon the *Horizontal Line A B*, in the same Dial Plain, then will the *East Dial* be a *Polar Dial*, and must behold the *South*, and the *Hour-Line* of 6 must be the *Hour-Line* of 12, upon which the *Stile* (or *Cock*) must stand. And the *Hour-Line* of 11 in the *East Dial* must be the *Hour-Line* of 5 at Night in the *Polar*; and the *Hour-Line* of 1, the *Hour-Line* of 5 in the Morning, in the *Polar Dial*.

C H A P. III.

*By help of an Horizontal Dial, in any Latitude, to
make a Declining Dial in that Latitude.*

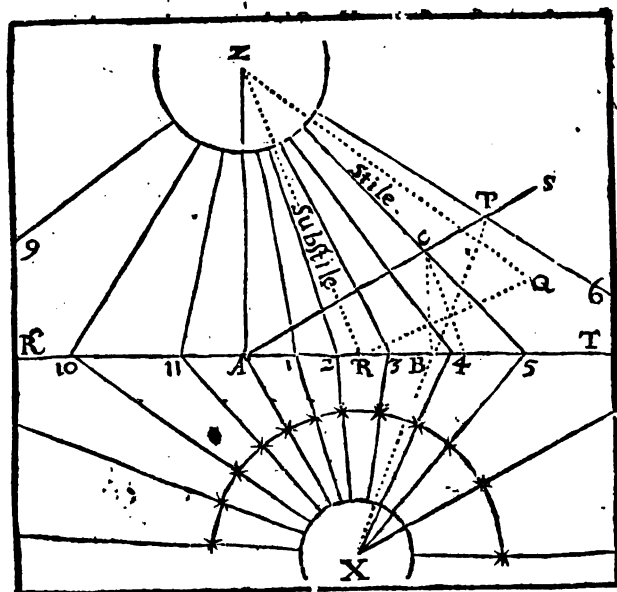

- S**uppose an upright Plain in the Latitude of 51 deg. 32 min. to decline from the South Westward. 30 deg.
1. Draw a right line K T, representing the Base or horizontal Line of your declining Plain.
 2. In this line, assume any point (as A.) and from it draw another line A S, making an Angle S A T equal to 30 deg. the Plain's declination, (towards K, if the Plain decline Eastward) or towards T, if it decline West, as here it doth.
 3. Upon this point A, erect a Perpendicular to K T. for the meridian line of the declining Plain; ----And from the same point A, another perpendicular to the Line A S, for the Meridian (or 12 o'Clock line) of the horizontal Dial, and in this line assume any point at pleasure (as X) for the Center of the horizontal Dial.
 4. Upon X describe the Horizontal Dial K T D E, for the Latitude of 51 deg. 32 min. and draw the Stile thereof X B, continuing it, till it cut the Line A S in P, and all the Hour-Lines till they cut the Line K T, in the Points 9, 10, 11, and 1, 2, 3, 4, 5.
 5. Make A Z equal to A P; so shall Z be the Center of the Declining Dial.
 6. Upon the Point B, (where the Line X P cutteth the Line K T) erect a Perpendicular, cutting the Line A S in C.
 7. Make;

R E C R E A T I O N S

7. Make A R equal to B C, and draw the Line Z R for the *Subsilar* Line of the *Declining Dial*.

8. From R erect a Perpendicular to Z R, making R Q equal to A B, and draw the Line R Q for the *Stile* of the *Declining Dial*.

9. From the Center of the *Declining Plain* Z, draw right Lines from the Center T to the several Points 9, 10, 11. and 1, 2, 3, 4, 5, &c. (where the Hour-Lines of the *Horizontal Dial* did cut the Line K T;) those Lines shall be the true *Hour-Lines* belonging to the *Declining Plain*, and the *Dial* is finished, which you may bring into what form you please, Round, Square, &c.

And here, for the ease of the Practitioner, in making of *Horizontal*, and such other *Dials* as are hereafter mentioned, I have inserted this following Table, and its Use.

A Table

H O R O M E T R I C A L.

A Table shewing the Degrees of each Hour-Line from 12, upon all *Horizontal* Dials, from 30 to 60 deg. of Latitude, and for all *Direct North* or *South* Reclining or Inclining Dials, where the Height of the Stile of such Dials is between 30 and 60 deg. of Altitude.

Hours	XI	I	X	II	IX	III	VIII	IV	VII	V
Distances from 12.	deg. m.		deg. m.		deg. m.		deg. m.		deg. m.	
30	7	37	16	7	26	34	40	54	61	49
31	7	51	16	34	27	15	41	44	62	30
32	8	05	17	1	27	55	42	32	63	11
33	8	19	17	27	28	37	43	20	63	49
34	8	31	17	54	29	13	44	5	64	24
35	8	44	18	20	29	50	44	49	64	58
36	8	57	18	45	30	27	45	31	65	30
37	9	10	19	9	31	2	46	12	66	10
38	9	22	19	34	31	37	46	50	66	29
39	9	24	19	58	32	11	47	28	66	56
40	9	45	20	21	32	44	48	7	67	21
41	9	57	20	44	33	16	48	29	67	47
42	10	10	21	7	33	46	49	12	68	11
43	10	22	21	29	34	18	49	44	68	33
44	10	32	21	51	34	47	50	10	68	54
45	10	43	22	12	35	17	50	46	69	15
46	10	54	22	33	35	44	51	15	69	35
47	11	5	22	53	36	11	51	42	69	53
48	11	17	23	13	36	37	52	9	70	11
49	11	25	23	33	37	3	52	35	70	28
50	11	35	23	52	37	28	53	0	70	43
51	11	45	24	9	37	52	53	21	70	59
52	11	55	24	27	38	15	53	46	71	13
53	12	5	24	43	38	37	54	8	71	28
54	12	13	25	2	38	58	54	29	71	41
55	12	22	25	10	39	19	54	49	71	54
56	12	32	25	34	39	40	55	9	72	5
57	12	40	25	50	39	59	55	28	72	17
58	12	48	26	5	40	18	55	45	72	28
59	12	56	26	20	40	36	56	3	72	38
60	13	4	26	34	40	54	56	19	72	48

The Use of this Table.

Suppose you were to make an *Horizontal* Dial for the Latitude of 35 Degrees, and a *Direct South* Dial for the Latitude of 55 deg. Or (which is all one) for any *Direct South* or *North* Dial, *Reclining* where the height of the Stile is 35 deg.

First

First draw a downright Line for the *Hour-Line* of 12, and upon any part thereof (towards the upper end) assume a Point for the *Center* of your Dial; and upon that Point with your *Compasses* opened to 60 deg. of your *Scale of Chords*, describe a *Semicircle*; Then take 90 deg. of your *Scale of Chords*, and set that distance from the *Hour-Line* of 12, upon the *Semicircle* both ways; and through those Two Points draw another Right Line, which will pass also through the *Center*, and be the *Hour-Line* of 6 in the *Morning* and 6 in the *Evening*.

Then go to this Table, and look in the first Column thereof for the Latitude 35 deg. and in the Line against 35, towards the Right Hand, you shall find,

deg.	min.	Hours
8	44	XI I
18	20	X II
29	50	IX III
44	49	VIII IV
64	58	VII V

} to stand un-
} der the hours
} of

Which Degrees and Minutes taken out of your *Scale of Chords*, and set upon the *Semicircle* on both sides of the Line of 12, Lines drawn from the *Center*, through those Points, shall be the true *Hour-Lines* proper for an *Horizontal Dial* for the Latitude of 35 deg. or of a *South* or *North Dial* in the Latitude of 55 deg. and of any *Direct North* or *South Reclining Dial*, where the *Stile's* Height is 35 deg.

C H A P. IV.

How, Mechanically, by help of an Horizontal Dial for any Latitude, to describe the Meridian, Substile, Stile, and the other Hour-Lines upon any other Plain in that Latitude, Regular or Irregular.

1. **U**nder the Plain upon which you intend to make your Dial; let there be erected a Scaffold of one or more Boards broad (according to the bigness of the New Dial you intend to make,) which Scaffold must be exactly Level, or parallel to the *Horizon*.

2. Being provided of an *Horizontal Dial* with Hours, Halves and Quarters (the larger the better) set it upon the Scaffold, the Center towards the *South*, and the *Stile* pointing up towards the *North Pole*; then

3. Having attained the true *Hour of the Day*, either by some true *Sun-Dial*, a *Solar Observation* by *Quadrant*, *Ring*, or other *Instrument*, or by a good *Minute-Watch* well rectified;

4. Bring

4. Bring the *Horizontal Dial* upon the Scaffold to the True Hour and Minute of the Day, at such convenient distance from the *Plain* as your Judgment will direct you; and there with small Tacks, or Cement, fix your Dial upon the Scaffold, so that it move not; there being a small string fixed in the Center of the Dial. Then,

5. Extend the Thread, which is in the Center of the Dial, along, justly, to touch the Top of the *Stile* of the Dial; till it doth touch the New Dial Plain, and note that Point; for that shall be the *Center* of the New Dial: The Thread it self is the *Stile* or *Axis*, and the Line under it (which may be found by help of a *Carpenter's Square* applied to the Plain and the String) is the *Subsilar Line* upon the Plain, by help of which the *Stile* may be made and fastned.

6. To draw the Hour-Lines: Extend the Thread fixed in the Center of the *Horizontal Dial*, over every Hour (Half and Quarter, if you will) till the Thread do touch the *Plain* upon the *Horizontal Line* thereof, (which will always be in the same Level with the upper part of the Scaffold,) and where they intersect this Line (or the Plain,) make Marks, noting them with the same Figures as the Thread passed over in the *Horizontal Dial*: So Lines drawn from the Center of the New Dial, through these Points, shall be the true Hour Lines of the New Dial.

But some Hour-Lines may run beyond the Limits of the Plain, or the passage of the Thread may be obstructed by some Objects, or Irregularities in the way, that it cannot come to touch the Plain; Then to help these, or the like Impediments,

7. Upon the *Horizontal Scaffold*, draw as large a *Square*, or *Parallelogram* as you can (or you may extend the Hour-Lines of the *Horizontal Dial* upon the Scaffold it self) and transfer (by help of the *Center-Thread*) all the hours of the *Horizontal Dial* into the sides of the *Square* or *Parallelogram*: And then,

8. Bring a Thread from the Center of the New Dial, and rest it upon the Hour-Point marked in the side of the *Square* or *Parallelogram*: Then the Thread in the Center of the *Horizontal Dial* carried along, so as only to touch the other Thread from the Center, will describe the Hour-Line desired, whether upon an *Even* or *Uneven Plain*, from the Center of the New Dial.

Thus far for Dials whose Centers will fall within their Plains; but for such as decline much from the South towards the East or West, in such the Thread which passeth from the Center of the Horizontal Dial, by the side of the Stile thereof, the Thread will not meet with the Plain at all, or (at least) not in a great distance, so that no Center can be found upon the Plain it self. In such Cases you must,

9. Set up a *Board* or other *Object*, over, or on that side of the *Plain* towards which the *Axis* tendeth, to receive the Center; and then, fixing a Thread there, by that, and the other Thread you may describe all the Hour-Lines, as was before shewed in *Irregular Plains*: And the Thread from the Center will be the true *Axis* or *Gnomon* of the *Dial*, and must be fixed to the Wall by two Stays.

C H A P. V.

Of Projective Dials.

BY this Artifice *Hour-Lines* may be Projected upon all kinds of *Superficies*, without any regard had to their standing; either in respect of *Declination*, *Reclination*, or *both*; Or whether the *Plains* be *Flat* or *Curved*; *One* or *more*: For if a *Point* be assigned, wherein the *Hour-Lines* and *Axis* shall concur, *Hour-Lines* may be Projected upon such *Plains*, and an *Axis* set up after the usual manner, by the directions following.

First, To the *Point* assigned (upon any side of it) by help of a *Semicircle*, or other *Level*, stretch out an Horizontal Thread, serving for the Horizontal Line, which *Line* (or *Thread*) need not be one single Line, but may be returned by *Two*, *Three*, or more *Angles*, provided that all the parts of it do lie in the same *Superficies*, and parallel to the *Horizon*.

Secondly, With a Perpendicular Thread held up, project the Sun into the assigned *Point*, and into the Horizontal Thread also, and there stick in a *Pin*, or make a *Mark* upon the Horizontal Line, through which the Shadow cutteth; and at the same Instant also take the Sun's *Altitude*.

Thirdly, By the *Altitude* taken, find out the Sun's *Azimuth* for that time. This *Azimuth*, whatever it be, is represented by the *Mark* before made in the Horizontal Line or Thread.

Fourthly, Apply a *Paistboard* to the assigned *Point*, holding it flat, that it may lie in the same *Plain* with the Horizontal Thread; and upon this *Paistboard* protract your *Azimuth*, by a Thread extended from the *Point* assigned for the *Center*, to the *Mark* made upon the Horizontal Thread. This done,

Fifthly, By help of that *Azimuth* upon the *Paistboard*, protract the *Meridian Line*, observing the true *Coast*; and to the *Meridian* thus found, describe an Horizontal Dial for the place.

Sixthly, Apply the *Paistboard* to its place again, all things standing right as before, project all the *Hour-Lines* into the Horizontal Thread from the *Paistboard*, and make *Marks* upon the Horizontal Line from the *Points* of each several *Hour*.

Seventhly, Project the *Meridian Point* by a Perpendicular Thread upon some *Object*, into that place whereabouts you imagine the *Axis* of the *World* would pass, whether it be above or below, from the *Point* assigned for the *Center*.

Eighthly, By help of a *Semicircle* (or a *Quadrant* applied to a *String*) elevated, or depressed (as occasion offers) from the *Point* assigned for the *Center*, according to your *Latitude*, project the *Pole of the World*.

Ninthly, Extend a *Thread* from the *Point* assigned for the *Center* to the *Pole of the World*, which *Thread* will represent the *Axis*.

Tenthly

Tenthly, By the Points upon *the Horizontal Thread*, and *the Axis*, (either by your *Eye*, laying *the Axis* to the Hour-Points, or laying the Hour-Points to *the Axis*,) you may project all the Hours-----Or without *the Axis* you may content your self with the Pole-Point projected into *the Meridian*: For, if from the Point assigned for *the Center*, or meeting of the Hours and *Axis*, you extend a *Thread* to each Hour-Point in the Horizontal Line, and do repose (by your *Eye*) the same *Thread* upon the Pole Point, then shall the Shadow of *the Thread* give you that Hour Line; and so you may do for all the rest.

Eleventhly, Your *Thread* or *Axis*, lying in its true situation, you may easily fit an *Axis* to the same posture. If your Dial be described upon a Plain *Superficies*, you may then (by one side of a *Square*, applied to *the Thread* or *Axis*, and the other side lying upon the Plain,) find out the *Substile*.----But if the *Dial* be described upon a *Curved Superficies*, or upon more than *One*, then must you be content to set up your *Axis* by the direction of *the Thread* only.

Twelfthly, The Point assigned for *the Center* being a Point of *the Axis*, is, as it were, *the Apex* of *the Gnomon*, unto which all *the Work* is projected. But if it be required to set up an *Axis* to such a *Superficies* upon which the Hours and *Axis* will not meet at any tolerable distance; in such a case set up any point (of *Wyre*, or such like) of such distance from the *Superficies*, as that the Hours and *Axis* may be distinct, and through that point let it be required to make *the Axis* pass. You have no more to do, but only to project to this point, as before, by letting the shadow of a perpendicular *Thread* pass through that point, and noting the same upon the Horizontal *Thread*; and counting that end of the *Wyre* as your *Center*, proceed as before; for the *Thread* that lies to project the Hours is a *Pattern* for *the Axis*.

Now this is a *General* way to project Hour-lines upon *one*, or *many Superficies*, be they plain or curved, *one* or *more*, and that without any laborious Inquisition of any of their situations, in respect of *Declination*, *Reclination*, or *both*.

C H A P. VI.

Of Reflected Dials.

IF a piece of *Looking-Glass* (of about one third part of an Inch diameter) be Horizontally fixed upon *the Soyle* or *Transome* of any *Window*, unto which *the Sun* hath free access; you may draw *Hour-lines* upon any Plain, whether *Horizontal*, *Reclining*, or *Inclining*, be they one or more; by which the true Hour of the day may be discovered by *the spot of Light* which the Sun shall reflect from *the Glass* upon any of *the Plains*: And that by these Precepts following.

First, The *Glass* being plac'd truly Horizontal, observe *the spot of Light* that the Sun casts, and make a Mark at it.

Secondly, And at the same time take the Sun's *Altitude*, and find its *Azimuth*.

Thirdly, Extend an *horizontal Thread* in the same *Level* with the *Glass*, but within the Room.

Fourthly. Project *the Azimuth* into *the horizontal Thread*, by holding up a perpendicular Thread in such a place, that, though it hang at liberty, you may at once discern both *the Mark of the spot of Light*, and the *Glass* likewise; and then observe where *the perpendicular Thread* seems to cut *the horizontal Thread*; and at that apparent intersection, make a mark upon *the horizontal Thread* for *the Azimuth*.

Fifthly, Apply a *Paistboard* to *the Glass*, so that it may be stayed upon some *Rest*, that after it is taken away, it may be restored to its place again, without any alteration. Let it be also placed *horizontal*, so that it may have full relation to *the horizontal Thread*.

Sixthly, At the *Glasses Center* make a Point for *the Center* upon the *Paistboard*, and extend a *Thread* from the *Center* upon the *Paistboard*, till it touch the *Mark* made for the *Azimuth* upon *the horizontal Thread*, and draw upon *the Paistboard* that Line which the extended *Thread* figures out thereupon: Afterwards, unto the same *Azimuth* upon the *Paistboard*, draw a *Meridian Line*, and to it an *horizontal Dial* for the place; and applying the *Paistboard* again to its former situation, project *the hours* thereon unto *the horizontal Thread*, and there make *Marks*, or tie *Knots*.

Seventhly, Then project *the Meridian* (by a perpendicular Thread, covering in appearance, both *the Mark* at 12, and *the Glass*) unto the contrary *Coast*, to that wherein the Pole is elevated above the *Horizon*; that is to say, In our *Northern* Climates you must project *the Meridian Southward* from *the Glass*, because the *North Pole* is elevated: And in this *Meridian* elevate your *Semicircle* or *Quadrant* from *the Glass Southwards*, till the *Plummet* fall upon the *Latitude*; so shall it point out, upon some Object set to receive it, the *North pole Reflected*.----Or else, if this be not convenient, (because in *Windows* which look towards the *South*, the *North Pole* will be without the Room, and so the *Axis* above the *Glass* extended towards that *Pole*, will be without also,) you may

may in such Cases, find out *the opposite Pole* to it; that is to say, that Pole which the former *Reflected Axis*, being extended through the *Glass*, and below it, would sign out; and that may be effected in this manner.

Eighthly, Project the *Meridian-line* towards the Pole that is elevated; that is with us, towards the *North Pole*; and then (because the *North Pole* is elevated by *Reflection*, towards the *South*, so, by the same Reason, the *South Pole* must be depressed towards the *North*) by your *Semicircle* or *Quadrant*, and String directed even with *the Center of the Glass*, express or project your Latitude downwards (but towards the *North*;) so shall the *Semicircle*, or *Thread*, point out the *Reflected South Pole* in the *Meridian*. Now, whether you will, or can (most conveniently) use the *Reflected North Pole* above the *Glass*, or the *Reflected South Pole* below it, you are to take your choice; for both the one and the other of them do represent the *Reflected Axis of the World*.

Ninthly, By this *Reflected Axis*, and the *Hour-points* signed out upon the *horizontal Thread*, you may easily project the *Reflected Hours*, upon any kind of *Superficies*, one or more, whatever they be that stand in the way.

C H A P. VII.

How (Mechanically) by help of a Trigon, to inscribe the Equinoctial, Tropicks, and the other Signs and Parallels of Declination, upon all sorts of Sun-Dials: As also the Azimuths, or Points of the Mariners Compass; the Almicanter, or Circles of the Sun's Altitude, &c.

I. How to make the Trigon.

THE *Trigon* may be made upon a piece of thin Board, or Sheet of *Paistboard*, as is the Figure *A B C D*; Through the middle whereof draw the Right Line $\odot E \alpha$, representing the *Equinoctial Circle* in the Heavens; then upon \odot , as a *Center*, with 60 deg. of your *Scale of Chords*, describe the *Semicircle* *A E B*; Then out of your *Chord* take 23 deg. 30 min. the quantity of the Sun's greatest *Declination*, and set them from *E*, on both sides of the *Equinoctial* to *L* and *M*, and draw the Two lines $\odot M \zeta$, and $\odot L \psi$, for the Two *Tropicks*; Then for the other intermediate Signs, set off 11 deg. 30 min. from *E*, both ways, to *F* and *G*, and draw the lines $\odot F \eta$, and $\odot G \chi$, for the lines of the Sun's Entrance into the Sign η and χ , and into ϑ and --- . Also, take 20 deg. 12 min. from the *Scale of Chords*, and set them from *E*,

RECREATIONS

E, on both sides, to H and K, and draw the lines $\odot H \approx$, and $\odot K \approx$ for the lines of the Sun's Entrance into the Signs \approx and τ , and into Π and Ω ---Then towards the upper ends of the several lines, $\odot L$, $\odot H$, $\odot F$, $\odot E$, $\odot G$, $\odot K$, $\odot M$, make small Holes, through which to put a small String : And thus is your *Trigon* finished, and fitted for the inserting of the Parallels of the Twelve Signs into all sorts of Sun-Dials, either *Direct* or *Reclining*, *One* or *more*, *Contiguous* or *Separate* :-----But if you would put in other *Parallels* of *Declination*, as such as when the Days are just 8, 9, 10, 11, 12, 13, 14, 15 or 16 Hours long, Then you must insert into your *Trigon* such degrees of *Declination* as the Sun hath when the Day is so many Hours long, as you would describe upon your Dial : And so in the Latitude of *London*,

			deg. min.			
When the day	8	} or {	Hours long, the	} Degrees of		
is either	9				16	21 40
	10				15	16 55
	11				14	11 37
					13	5 55
		Sun hath		Declination.		

And such degrees of *Declination* you must put into the *Trigon*, between the *Equinoctial* and the *Tropicks*.

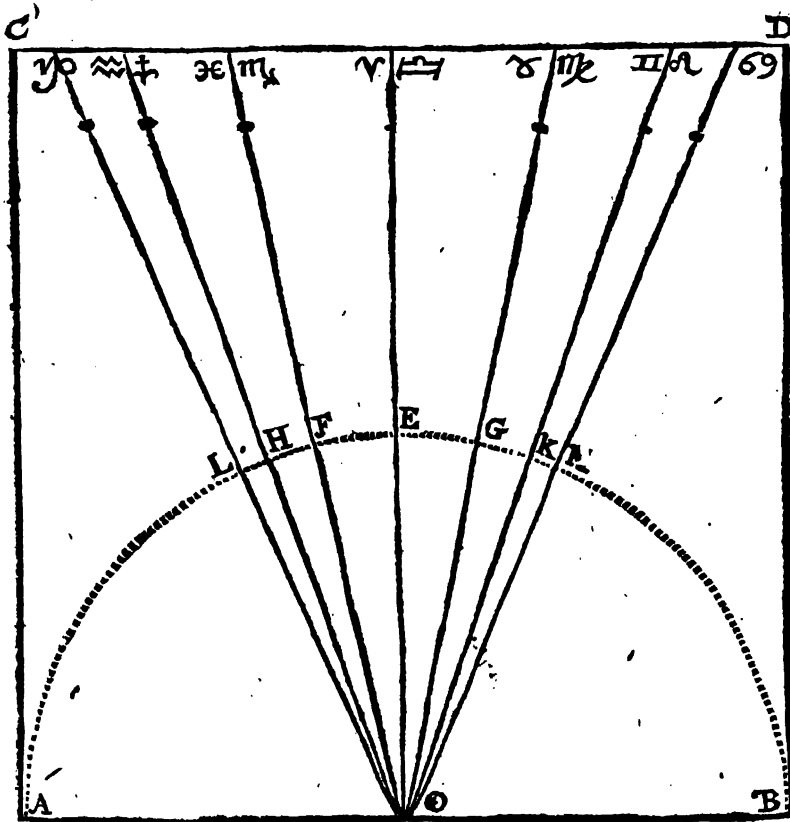

II. *How to insert the Equinoctial, the Tropicks, and other Intermediate Parallels of Declination into all sorts of Dials.*

YOU are to Note, that the *Parallels of the Signs, the Diurnal Arches, the Azimuths, the Circles of Altitude, and all other Circles relating to the Course of the Sun,* when they are described upon any *Sun-Dial,* are not shadowed out by the whole *Stile or Axis of the Dial,* as the *Hours* are, but by some One Point in the same *Axis*; as by a *Knob, Button or Notch,* filed in the *Stile of the Dial*; Or by a *hole in a Glass Window for projected Dials*; or by a piece of *Looking-Glass for Reflected Dials*; in all which Cases, the *Center* \odot , in the *Trigon,* is to be applied (in all Cases,) so that the line *A B* thereof, must lie upon the *Stile of the Dial* (if the *Dial* have a *Stile*) or *Parallel to the Axis of the World,* if it be an *hole in a Window, or piece of Looking-Glass*: And now, the *Trigon* being thus disposed, so that it may be turned about the *Axis,* the *Center* \odot always fixed in the same point.

Now suppose you would insert the *Equinoctial* into any *Dial,* (for one *Rule* serves for all *Plains* :) *First,* put a long small *String* through the *Hole* which is under $\gamma \approx$, tying a *Knot* on the back side, that it slip not through the *Hole in the Board*; Then apply the *Center* \odot to the *Point* (or *Button*) in the *Stile,* and the *Side A B* to the *Stile* it self. Now if you extend the *Thread* over the *Line* $\gamma \approx E \odot$, till it touch the *Dial-Plain,* that point of touching shall be one point through which the *Equinoctial* is to be drawn upon the *Plain*—Then turn the *Line A B* about upon the *Stile,* leaning either towards the *Right or Left Hand,* as occasion offers it self, extend the *Thread* till it touch the *Dial-Plain* in some other point, and that other point shall be another point through which the *Equinoctial* is to be drawn upon the *Dial*. And if your *Dial* be all but one plain *Superficies,* Two points will be sufficient to draw the *Equinoctial* by, it being a *Great Circle of the Sphere,* and so a *Right Line* upon all plain *Superficies*; But if the *Dial* consist of more than one *Plain,* then must you (in the same manner as before) find two points at least upon each *Superficies*; which you may easily and speedily do, by turning the *line A B* of the *Trigon* about (or parallel to) the *Axis,* and extending the *Thread* over the *line* $\gamma \approx E \odot$, till it touch the *Plain*.

In like manner, if you would insert the *Tropick of Capricorn* into your *Dial,* you must put the *String* or *Thread* through the *Hole* under w , and then apply the *Point* \odot to the *Point* in the *Axis,* and the *Side A B* to the *Stile,* extend the *Thread* over the *line* $w L \odot$, till it touch the *Plain,* and that point of Touch shall be one Point through which the *Tropick of Capricorn* is to be drawn—Again, Move the *Trigon* (in this position) towards the *Right or Left Hand* (as occasion requires,) extend the *Thread* over the same *Line* $w L \odot$, till it touch the *Plain,* and that shall be another point through which that *Tropick* must be drawn; And in this manner may you find as many points upon the *Plain* as you please, and the more the better (for these *Parallels* will not be straight lines, as the *Equinoctial* line was, but *Conick Sections, or Curved lines*) through which points a line being traced, with an even Hand, shall be the *Tropick of Capricorn* upon your *Dial-Plain* or *Plains*.

And

And in this manner may the *Tropick of Cancer*, and all the *parallels* of the other Signs be drawn, if first you put the String through the respective Holes, and apply the *Trigon* to the *Axis*, and extend the Thread till it touch the Plain, as before, you may find as many points as you please, through which to draw your *parallel*. And let this suffice for the Inscription of the *parallels* of the Signs of the *Zodiack*-----And if you would insert the *parallels* for the length of the Day, they are to be done in the same manner, if instead of the *Declination* for the Signs, you put into your *Trigon* the *Declinations* answering to the length of the days you intend to insert into your Plain, as is before directed.

III. To insert the Parallels of the Sun's Altitude into all Projected or Reflected Dials.

THis may be performed by a *Quadrant* drawn upon a large piece of Board, or Sheet of Paistboard, and divided into 90 Deg. after the usual manner. For if you apply a Board, or other matter to the *Glass* (if a *Reflected Dial*; or to the *Hole*, if it be a *projected Dial*) so that it may lie exactly level, or parallel to the *Horizon*; Which Board thus fixed, apply the *Center* of the *Quadrant* to the *Center* of the *Glass* or *Hole*, setting one side of the *Quadrant* perpendicular, the other parallel to the *Horizon*, and a small *String* or *Thread* in the *Center*: Then consider what *Circle of Altitude* you would describe upon your *Dial-plain* or *plains*, (suppose 30 degrees:) The *Quadrant* standing in the fore said posture, upon any part of the *Horizontal Board*, extend the *Thread* by the *Superficies* of the *Quadrant* over 30 deg. thereof, till it touch the *Wall* or *Ceiling* of the *Room*, and where it touches any Object that is in the way, that point of touch shall be one point through which the *parallel* of 30 degrees of *Altitude* shall pass.-----Again, Move the *Quadrant* (the *Center* being still kept in the *Center* of the *Glass* or *Hole*, but the *Horizontal side* moved to some other part of the fixed Board) extend the *Thread* again over 30 deg. of the *Quadrant* till it touch the *Wall* or *Ceiling* of the *Room*, and that shall be another point through which the *parallel* of 30 deg. of *Altitude* shall pass. And in this manner may you find as many points as you please, by which to describe that *parallel*-----If both the *Glass* and *Ceiling* be both *Horizontal*, then these *parallels* of *Altitude* will be perfect *Circles*, whose *Center* will be in the *Vertical point* directly over the *Glass*, and in the same Plain with the *Ceiling*. But if the Plains be *Upright*, or *Reclining*, then these *parallels* will be *Curved Lines*, as the *parallels* of the *Signs*, and must be drawn through the respective points found with an even Hand---And as this *parallel* of 30 deg. of *Altitude* was drawn, so may any other, as of 10, 20, 40, 50, &c. be, by extending the *String* in the *Center* over those degrees in the *Quadrant* till they meet with the Plain.

IV. How

IV. *How the Azimuths, or Vertical Circles may be described upon all sorts of Plains.*

FOR the performance of this Work, you must first find a *Vertical point*, above, tending to the *Zenith* of the *Glass* (if it be for a *Reflected Dial*; Or below, towards the *Nadir* of the *hole*, if it be a *Projected Dial*.) This Point thus found (which may be done by a *Plumb Line*, or perpendicular *Thread* from the *Ceiling* to the *Glass*, or from the *Hole* to the *Floor*) may be called the *Reflected Vertical point*, in which a *Thread* or *String* is to be fixed: And by a point found in the *Reflected Axis* of the *Horizon* the *Azimuths*, may be drawn; as the *Hours* were by a point found in the *Reflected Axis* of the *Equinoctial*: In manner following:

Upon a Sheet of *Paistboard*, or like Material, let there be described such *Azimuth Circles* as you intend to describe upon your *Plain*; whether they be the *Degrees* of the *Horizon*, or the *points* of the *Mariners Compass*: for both are put on by the same Method, only vary in their *Denomination*, One being numbered by 10, 20, 30, &c. the other by *South, S by W, S S W, &c.*

These *Azimuth Lines* being drawn upon the *Paistboard*, place the *Center* of them upon the *Center* of the *Glass*, and the *South Azimuth* thereof upon the *Meridian* of the place, so that the *Paistboard* may be there fixed in the very *Plain* of the *Horizon*, that is, perfectly *horizontal* or *level*.

Then take the *Thread* which is fixed in the *Glass*, and draw it over any *Azimuth* marked on the *Paistboard*, till it meet with some *Object* in the *Room*, as a *Post, Wall*, or the like, and there fix it.

Then take the *Thread* whose end is fixed in the *Reflected Vertical point* over the *Glass*, and lead it along by the *horizontal Thread*, till it meet with the *Wall* or *Ceiling* of the *Room*, and where it toucheth, that shall be one point through which that *Azimuth* must be drawn. In like manner, move the same *Thread* higher or lower at pleasure, by the side of the *horizontal Thread*, till it be opposed by some *Wall* or *Ceiling*, and there make another *Mark* for a second point, through which that *Azimuth* must be drawn: And now have you *Two Points*, the which (if they fall both upon one and the same *Superficies, Wall* or *Ceiling*.) are sufficient; for the *Azimuths* being *Great Circles* of the *Sphere*, will be straight *Lines*; and so may you find *Two Points* upon each *superficies*, if there be more than *One*: Or, by the first *Two Points*, if a *Thread* be so situated, that it may interpose between the *Eye*, and the said *Two Points*, you may make as many *Points* as you please upon all the *Superficies*, be they never so many: And in this manner may what *Azimuths* you please be inscribed upon any *Plain* or *Plains*.

Note, In all the Reflected Dials mentioned in this Chapter, although the Plains themselves may be many, and those Regular or Irregular, Contiguous or Separate; yet (in all Cases) the Glass must lie level or parallel to the Horizon; which is a thing very difficult to effect by any Instrument, the Glass being so small; Wherefore One Mechanical way may be this, which I think is inferior to none:

In the Hole made in *the Transome of the Window*, in which *the Glass* is to be fixed, pour some Drops of Fair Water, or other Liquor, till the Hole be full; then, the Sun shining, will cast *the Reflex* thereof upon *the Ceiling*, which point of *Reflected Light* mark upon *the Ceiling*, and incontinently, with a Sponge, dry up the Water which is in the Hole: And having *Cement* (or the like) to fasten *the Glass* with, put it in the Hole, and *the Glass* upon it, and while *the Cement* is yet warm and pliable, move *the Glass* upon it till it cast its shadow upon that point of *the Ceiling* to which *the Water* was *Reflected*; and by this means shall your *Glass* be truly placed.

C H A P. VIII.

Of Dials which shall give the Hour of the Day by the Sun, and by the Stars in the Night-Season: How such Dials may be made, and how to make Use of them.

There are several ways by which any Stars Hourly distance from the Meridian (call'd the Stars Hour) may be obtained: As,

I. By any Quadrant, or other Instrumental Dial, which giveth the Hour of the Day by the Sun.

I Will illustrate this in the Use of Mr. Gunter's Quadrant, it being an Instrument more frequently known than any other of that kind: For, If you observe the same Rules in finding the Stars Hour, as is directed for finding of the Hour of the Day by the Sun; that is, by setting the Bead to *the Stars Declination*, instead of *the Sun's Declination*, and then observe *the Stars Altitude*, as if it were *the Sun's Altitude*, the Bead shall then shew among the Hour-Lines the Stars Hour, or the Stars Hourly distance from the Meridian.

But here you are to note, *That this way of finding the Stars Hours is peculiar to such Stars only as are between the Tropicks. Wherefore, another more general way may be this:*

II. By

II. *By a Sun-Dial made under the Soyl, and on the Jaums of a Jetty Window, on the inside of a Room.*

And such a *Dial* may be made by the Rules before given in *Chap. V.* hereof ; Or thus :

HAVING made a small round hole in any Quarry of Glafs in the Window, and darkned the other part of the same Quarry round about the hole, you must upon the Window-Board draw a Meridian Line, which Line must pass directly under the hole before made, and must be transferred to the Ceiling of the same Room, by the help of Perpendicular Threads.

Then from the hole in the Window, to the Meridian Line on the Ceiling, extend a String, till it make an Angle equal to the *Latitude* of the place you make the *Dial* in, and where the String (with this condition) so resteth, fix the end of the String in that point of the Ceiling, letting the other part of the String hang at liberty.

This done, by help of an *Horizontal Dyal*, whose Center (for the present) must be placed in the hole in the Window; the Lines of which *Dial* must also be extended by a Thread fixed in the Center thereof, by which Line extended over each Hour, and the String before fixed in the Ceiling, the Hour Lines may be transferred and marked upon, or under the Window Board ; and also upon the *Jaums* and *Cheek Posts* of the said Window, and there numbered by Letters or Figures.

Now such a *Dial* being made, I shall shew,

How to find the Hour by the Sun in the day time, and any Stars How (or Horary distance from the Meridian) in the Night Season.

1. *By the Sun.*

TH E *Sun* shining through the hole before made in the Window, move the String, whose end is fixed in Ceiling, along the Hour Points which are marked about the Window, until such time that the Spot of Light that cometh through the hole shineth upon the String, and then see upon what Hour, or part of an Hour the string resteth, for that is the true time of the Day.

2. *By the Stars.*

TH IS differeth little from the former ; for when through the Window you see a *Star* you know, and would know his Hour, move the String along the Hour Points as before, till such time as you bring your Eye, the String, the Hole, and the *Star* all in one and the same Plain or right Line ; for then will the String rest upon that *Stars* Hour, or his *Horary* distance from the Meridian.

III. *By a Dial made in a Yard or Garden.*

IN some convenient open place erect a Pole perpendicular to the *Horizon*, about 10 or 12 foot high; then provide a Frame of Wood in form of a *Parallelogram*, of what bigness you please, (but the sides being 2 foot broad, and 3 foot long, is a competent bigness;) within the *Area* of this Frame make the true Hour-Lines of an *East* and *West* Dial; which Hour-Lines may be of reasonable big Wyre; and upon the Edges of the Frame, set the Numbers of the Hours, the Forenoon Hours on the *East* side, and the Afternoon Hours on the *West* side, and over the Hour-Line of Six erect an *Axis* (of a competent Length) as if it were a *Sun-Dial*: Which Dial being thus prepared, if you set it upon the former erected Pole, so that the Two Ends of the Frame may stand due *North* and *South*, and the Stile thereof Parallel to the *Axis* of the World, then is it fit for use, either to find the Hour of the Day by the *Sun*, or the *Stars* Hour in the Night.

1. *By the Sun.*

THis is all one as if it were a *Dial* made against a Wall; for the shadow of the *Axis* upon the Frame will shew the Hour of the Day.

2. *By the Stars.*

WHen you see a *Star* you know, and would find that *Stars* Hour; move your self about the Dial-Post (coming near to it, or going farther from it) as occasion offereth, till you bring your Eye, the *Axis*, and the *Star* in the same Plain or Right Line, and then mind what Hour-Line (or between what Hour-Lines) is intercepted by that view, for that is that *Stars* Hour; and by this *Dial* you may at any time know what *Stars* are upon the *Meridian*.

IV. *To know what Stars are upon the Meridian.*

IF you go behind the *North* End of the Frame, and look by the side of the Frame, you shall see what *Stars* are then upon the *South* part of the *Meridian*.

And if you go behind the *South* End of the Frame, and look by the Side of the Frame, you shall there see what *Stars* are upon the *North* part of the *Meridian*.

And thus the Stars Hour may be found by any of the forementioned ways: which obtained, the true Hour of the Night may be found: But first you must know the Right Ascension of the Sun, and also of the Star, whose Hour you found by your Dial. And to that end I have inserted the Two following Tables.

A Table of the Complement of the Sun's Right Ascension at Mid-night, every Night in the Year.

Days	Jan.		Feb.		March		April		May		June	
	h.	m.	h.	m.	h.	m.	h.	m.	h.	m.	h.	m.
1	4	25	2	18	0	32	10	39	8	46	6	41
2	4	21	2	14	0	28	10	35	8	42	6	37
3	4	17	2	10	0	24	10	31	8	38	6	33
4	4	13	2	6	0	21	10	27	8	34	6	29
5	4	9	2	2	0	17	10	24	8	30	6	24
6	4	4	1	58	0	14	10	20	8	26	6	20
7	4	0	1	54	0	10	10	16	8	22	6	16
8	3	56	1	50	0	7	10	13	8	18	6	12
9	3	51	1	46	0	3	10	9	8	14	6	8
10	3	47	1	43	11	59	10	6	8	10	6	4
11	3	43	1	39	11	55	10	2	8	6	6	0
12	3	38	1	35	11	52	9	58	8	2	5	56
13	3	34	1	31	11	48	9	54	7	58	5	52
14	3	30	1	27	11	45	9	50	7	54	5	48
15	3	26	1	24	11	41	9	47	7	50	5	43
16	3	22	1	20	11	37	9	43	7	46	5	39
17	3	18	1	16	11	34	9	39	7	42	5	35
18	3	14	1	12	11	30	9	35	7	38	5	31
19	3	10	1	8	11	27	9	31	7	34	5	27
20	3	6	1	5	11	23	9	28	7	30	5	23
21	3	2	1	1	11	19	9	24	7	26	5	18
22	2	57	0	57	11	16	9	20	7	22	5	14
23	2	53	0	54	11	12	9	16	7	18	5	10
24	2	49	0	50	11	8	9	12	7	14	5	6
25	2	45	0	47	11	5	9	9	7	10	5	0
26	2	41	0	43	11	1	9	5	7	6	4	58
27	2	37	0	39	10	57	9	1	7	2	4	54
28	2	33	0	35	10	54	8	57	6	58	4	50
29	2	29			10	50	8	53	6	54	4	46
30	2	25			10	46	8	50	6	49	4	41
31	2	22			10	43			6	45		

Days

RECREATIONS

Days	July		August		Septemb.		October		Nov.		Decem	
	h.	m.	h.	m.	h.	m.	h.	m.	h.	m.	h.	m.
1	4	37	2	35	0	41	10	52	8	53	6	45
2	4	33	2	31	0	37	10	48	8	49	6	40
3	4	29	2	27	0	34	10	45	8	45	6	35
4	4	25	2	23	0	30	10	41	8	41	6	31
5	4	21	2	20	0	27	10	38	8	38	6	26
6	4	17	2	16	0	23	10	34	8	33	6	22
7	4	13	2	12	0	19	10	30	8	29	6	18
8	4	9	2	9	0	16	10	26	8	24	6	13
9	4	5	2	5	0	12	10	22	8	20	6	9
10	4	1	2	2	0	9	10	19	8	15	6	4
11	3	57	1	59	0	5	10	15	8	11	6	0
12	3	53	1	54	0	1	10	11	8	7	5	55
13	3	49	1	50	11	58	10	7	8	2	5	51
14	3	45	1	46	11	54	10	3	7	58	5	46
15	3	41	1	43	11	51	10	0	7	53	5	41
16	3	37	1	39	11	47	9	56	7	49	5	36
17	3	33	1	35	11	43	9	52	7	45	5	32
18	3	29	1	32	11	40	9	48	7	41	5	27
19	3	25	1	28	11	36	9	44	7	37	5	23
20	3	21	1	25	11	33	9	40	7	32	5	19
21	3	17	1	21	11	29	9	36	7	28	5	15
22	3	13	1	17	11	25	9	32	7	24	5	11
23	3	9	1	14	11	22	9	28	7	20	5	6
24	3	5	1	10	11	18	9	24	7	15	5	2
25	3	2	1	7	11	15	9	21	7	11	4	57
26	2	53	1	3	11	11	9	17	7	7	4	53
27	2	54	0	58	11	7	9	13	7	3	4	49
28	2	50	0	56	11	3	9	9	6	58	4	44
29	2	46	0	52	10	59	9	5	6	54	4	40
30	2	42	0	49	10	56	9	1	6	49	4	35
31	2	39	0	45			8	57			4	30

A Table of the Right Ascension of 46 Eminent Fixed Stars throughout the *Zodiack*.

The Names of the S T A R S.	R. Ascen.	
	H.	M.
S outh Star in the Whale's Tail	0	27
The Girdle of <i>Andromeda</i>	0	51
The formost Horn of the Ram	1	36
Whales Belly	1	46
<i>South</i> Foot of <i>Andromeda</i>	1	43
<hr/>		
The Whales Jaw	2	45
The Brightest of the Seven Stars	3	28
<i>Aldebaran</i> , or the Bull's Eye	4	17
<i>Capella</i> , or the Goat	4	52
Formost Shoulder of <i>Orion</i>	5	8
<hr/>		
<i>Orion's</i> Head	5	17
Middlemost in <i>Orion's</i> Belt	5	20
<i>Cyrius</i> , or the Great Dog	6	30
<i>Procion</i> , or the Lesser Dog	7	22
The Lowermost Head of the Twins	7	26
<hr/>		
<i>North</i> <i>Ascellus</i>	8	23
<i>South</i> <i>Ascellus</i>	8	25
<i>Cor Leonis</i> or the Lyon's Heart	9	50
<i>Cauda Leonis</i> , or the Lyon's Tail	11	32
<i>Vindemiatrix</i>	0	46
<hr/>		
<i>Spica Virginis</i>	1	8
<i>Arcturus</i>	2	1
Left Shoulder of <i>Bootes</i>	2	19
<i>South</i> Ballance	2	23
<i>North</i> Ballance	3	3
<hr/>		
Bright Star of the Crown	3	25
<i>Antares</i> , or the <i>Scorpion's</i> Heart	4	9
<i>Hercules</i> Right Shoulder	4	11
<i>Hercules</i> Head	5	0
Head of <i>Ophyncus</i>	5	20
<hr/>		
<i>Lyra</i> , or the Harp	6	22
<i>Vultures</i> Tail	6	51
The Swan's Bill	7	18
The Vulture	7	35
Lowermost Horn of the Goat	8	30
<hr/>		
Swan's Breast	8	11
Swan's Tail	8	31
Lowermost Wing of the Swan	8	33
Girdle of <i>Cepheus</i>	9	25
<i>Pegasus</i> Mouth	9	28
<hr/>		
Right Shoulder of the Water-bearer	9	47
<i>Fomabaunt</i>	10	39
<i>Scheat</i>	10	48
<i>Mercha</i>	10	49
Head of <i>Andromeda</i>	11	32
<hr/>		
<i>Cassiopea's</i> Chair	11	53

R E C R E A T I O N S

V. To find the Hour of the Night by the Stars.

Example.

Observing by some of the ways before prescribed, that upon the last Day of *December*, I found that the *Great Dog's* Horary distance from the *Meridian* was 9 Hours, 22 Minutes; which set down as followeth:—Then (by the *First Table*) I find the Complement of the *Sun's R. Ascension* on the 31st of *December*, to be 4 Hours 30 Minutes; which set down under the former-----And (by the *Second Table*) I find the *R. Ascension* of the *Great Dog* to be 6 Hours, 30 Minutes; which set down under the Two former: All which being added together, do make 20 Hours, 22 Minutes. Which (because it is above 12 Hours) subtract 12 Hours from the Sum, the Remainder will be 8 Hours, 22 Minutes for the true Hour of the Night.

	H.	M.
The <i>Great Dog's</i> Hour	9	22
The Comp. of the <i>Sun's R. Ascension</i> , <i>December</i> 31	4	30
The <i>Great Dog's R. Ascension</i>	6	30
	<hr/>	
	The Sum	20 22
	Subtract	12 00
	<hr/>	
	There Remains 8 22	

For the true Hour of the Night.

VI. Another way to find the Hour of the Night, by seeing any Star upon the Meridian,

I have already intimated, how you may know by the *Dial* upon a Post before mentioned, what Stars are upon the *Meridian* at any time of the Night; It resteth now to shew how (from thence) to find the Hour of the Night.

Example.

Suppose, therefore, that upon the 20th Day of *January*, I find *Aldebaron*, or the *Bull's Eye*, to be upon the South part of the *Meridian*, then (by the *First Table*) I find the Complement of the *Sun's R. Ascension* on the 20th of *January*, to be 3 hours, 6 minutes-----And (by the *Second Table*) the *R. Ascension* of the *Bull's Eye* (or *Aldebaron*) to be 4 hours, 17 minutes. These Two added together make 7 hours, 23 minutes, for the true Hour of the Night.

	h.	m.
The Comp. of the <i>Sun's R. Ascen.</i> Jan. 20	3	6
The <i>R. Ascension</i> of the <i>Bull's Eye</i>	4	17
	<hr/>	

Their Sum 7 23

Which is the true Hour of the Night, Jan. 20.

CONCLUSION.

There are several other ways to find the Hour of the Day or Night, by the *Sun, Moon, or Stars*; as by *Quadrants, Rings, Cylinders, Walking Staves, Nocturnals* of several Kinds: By the Shadow of the Moon upon a Sun-Dial, and many other ways. But forasmuch as these Instruments are to be had at any Shop where *Mathematical Instruments* are Made, or Sold, I shall forbear to say any thing of them in this place: Only I shall exhibit to the Practitioners View, Two Tables, by help of which the Usual Furniture may be put into all sorts of Sun-Dials, *Plain, Concave, Convex, Regular or Irregular*. And also all the forementioned *Quadrants, Rings,* and other *Instruments,* which shew the *Hour* and *Azimuth* of the Sun by the *Altitude* thereof, are made.

D

A Table

A Table of the Sun's *Azimuth* from the *South* for every Hour and Quarter, at his Entrance into every of the XII Signs of the *Zodiack*, in the Latitude of *London*, 51 deg. 32 min.

	♈	♉	♊	♋	♌	♍	♎	♏	♐	♑	♒	♓
Hours	<i>Azim.</i>	<i>Azim.</i>	<i>Azim.</i>	<i>Azim.</i>	<i>Azim.</i>	<i>Azim.</i>	<i>Azim.</i>	<i>Azim.</i>	<i>Azim.</i>	<i>Azim.</i>	<i>Azim.</i>	<i>Azim.</i>
	D. M.	D. M.	D. M.	D. M.	D. M.	D. M.	D. M.	D. M.	D. M.	D. M.	D. M.	D. M.
XII	00 0	00 0	00 0	00 0	00 0	00 0	00 0	00 0	00 0	00 0	00 0	00 0
1	7 10	5 53	5 37	4 55	3 54	3 53	3 52	3 52	3 52	3 52	3 52	3 52
2	14 22	13 24	11 10	9 40	7 57	7 40	7 10	7 10	7 10	7 10	7 10	7 10
3	21 27	19 53	16 44	14 13	12 11	11 10	10 37	10 37	10 37	10 37	10 37	10 37
I XI	27 56	26 0	22 13	18 52	16 22	14 45	14 13	14 13	14 13	14 13	14 13	14 13
1	34 14	32 1	27 32	23 22	20 15	18 17	17 38	17 38	17 38	17 38	17 38	17 38
2	40 12	37 40	32 41	27 41	24 6	21 53	20 59	20 59	20 59	20 59	20 59	20 59
3	45 39	43 4	37 32	32 8	29 44	26 30	24 25	24 25	24 25	24 25	24 25	24 25
II X	50 51	47 57	42 5	36 24	31 50	28 52	27 49	27 49	27 49	27 49	27 49	27 49
1	55 31	52 41	47 4	40 30	35 35	32 18	31 0	31 0	31 0	31 0	31 0	31 0
2	51 43	57 11	50 51	44 26	39 10	35 39	34 17	34 17	34 17	34 17	34 17	34 17
3	64 11	61 18	54 33	48 13	42 36	48 50	37 34	37 34	37 34	37 34	37 34	37 34
III IX	68 10	65 16	58 47	51 56	46 2	42 4	40 38	40 38	40 38	40 38	40 38	40 38
1	71 52	69 56	62 33	55 33	49 25	45 16	43 40	43 40	43 40	43 40	43 40	43 40
2	75 26	72 37	66 10	58 59	52 43	48 21	46 42	46 42	46 42	46 42	46 42	46 42
3	78 48	76 5	69 28	62 22	55 59	51 22	49 40	49 40	49 40	49 40	49 40	49 40
IV VIII	82 0	79 20	72 57	65 40	59 0	54 22						
1	85 8	82 42	76 12	68 53	62 8							
2	88 10	85 38	79 23	72 6	65 12							
3	91 9	87 50	82 28	75 7	68 12							
V VII	94 15	91 34	85 30	78 6	71 10							
1	96 51	94 25	88 27	81 9								
2	99 38	97 16	91 23	84 6								
3	102 25	100 7	94 22	87 4								
VI VI	105 8	102 54	97 12									
1	107 22	104 58	100 2									
2	110 36	108 26	103 0									
3	113 88	111 14	105 54									
VII V	116 3	114 3										
1	118 50	116 54										
2	121 41	119 47										
3	124 29	122 37										
VIII IV	127 24											

An Easie Way to make a Spot-Dial within a Room, without any Calculation, or Use of Threads; &c.

THIS may be done Two Ways, either 1. By the direct Rays of the Sun thorough a little Hole in the Glas: Or, 2. By the Reflected Rays from a small show of a *Looking-Glass*, set in a convenient place in the Window. The first way I account not so convenient, because the Hour-Lines will many of them fall on the Floor, Tables, &c.

The other way is this, 1. Take a little piece of *Looking-Glass* (common Glas may serve, but not so well) about the breadth of a sixpence; fasten this so in the bottom of the Window (or sides if you see good) that the Rays of the Sun may not be hindred from coming upon it (or as little as may be).

2. It is necessary that you have with you, upon this occasion, a rightly set Sun Dial Quadrant, &c. The like to find the several hours of the Day by being so provided, upon a clear Sun-shine Day, watch the Sun-Dial till the shadow is just upon some Hour-Line, then immediately observe where your spot of light falls on the Wall or Ceiling; and there with black Lead, or the like, make a mark, and also set a Figure by it of what hour it is. Do the same by the next hour, and so on as long as the Sun shines, so as to give a spot in the room.

3. About a Month or more after, observe in like manner by your Sun Dial where the spot falls on the Wall or Ceiling at the several hours, and make marks and figures as you did before, and you will find the hour spots now to fall far distant from where they were a Month ago.

4. This done with a long Ruler and black Lead, Ink, or the like, draw a long line joyning each pair of marks that have the same figure annexed to them, and each such line produced at both ends shall be the hour line for that hour; to which put, where you see fit, its proper figures, and in like manner do by the rest.

Note, 1. The best time of the year for the Operation is the *Spring*, or *Autumn*; other times of the year may serve, so as the times of observations be either *both before*, or *both after the solstices*, *June 11*, *December 11*.

Note 2. When an hour-line drawn upon the Ceiling comes to the Wall, there will be then needful a third observation where the spot falls on the Wall at that Hour; at which having made a mark, draw a straight line from the end of the line on the Ceiling, down to your mark, for that hour on the Wall; so will you have that hour-line compleat. In like manner you may do by the rest if there be need.

Note, 3. Your Glas, and what it stands on must be very firm; for if it be moved ever so little, 'twill not agree with your hour-lines.

They who please and have a convenient Room and Window, may by the very same method draw hour-lines to a spot of light coming throw a little hole in a Quarry of Glas, but then it will be convenient that the rest of the Quarry be darkned by pasting a piece of black paper, or the like, on the inner side, leaving the hole in the middle.

F I N I S.

RECREATIONS

Cryptographical.

THIS *Cryptographical Art* is of great use in many respects, but principally in *War*. And if we consider to what necessities great Princes and Potentates have been put unto to communicate their Minds or Intentions to their Correspondents before the improvement of this Art, it would make a man but of a reasonable understanding admire: Wherefore I shall here give you a very brief account of some of them, and afterwards shew some other more Artificial and absolute ways whereby Communication may be had both secretly and swiftly.

I. Of some Antient ways.

1. When *Histæus* the *Milesian* was kept Prisoner by *Darius*, and despairing of his return home, unless he could find out some way to send to *Aristagoras* (who was his Substitute at *Miletum*) to persuade his Revolt from *Darius*, but knowing that all Passages were stopt, and all Messengers strictly examined and searched; he at length found out this (both tedious and weak) course. He got a trusty Servant of his, the Hair of whose Head he caused to be shaved off, and then upon his bald Pate he writes his mind to *Aristagoras*, keeping his Servant privately about him till his Hair was somewhat grown, and then bad him haste to *Aristagoras*, and bad him cause him to be shaven again, and then upon his Head he should find what his Lord had writ unto him.

2. When *Harpagus* had a mind that *Cyrus* should hasten his Invasion on *Media* (*Cyrus* being then in *Persia*), his Letter he sent to him he inclosed in the belly of a Hare.

3. The *Lacedemonians* used this way to communicate their Letters to their Generals abroad, which in case of Interception, the Contents should not be discovered. They had made two round Sticks or Cylinders of the same length and thickness, one of which was delivered to the General when he set forth; and the other was kept at home by the chief Magistrate. When occasion was, they wound about the Stick a long narrow scrawl of Paper or Parchment, in such manner, like the threads of a Screw, so that the edges of the Paper or Parchment should always lie close together; the Paper thus fitted to the Stick (or Cylinder) they wrote their Letters upon the transverse junctures of the Paper, so that one

R E C R E A T I O N S

one part of each Word or Letter was in one place, and the other in another: When they had finished their Writing, they took off the scroll and sent it to the General, who knew how to apply it; and if it had been intercepted, the Enemy could make nothing of it; and this manner of Writing they called *Scytale*.

4. The *Milefians* used to Write their Letters, and inclose them in a Cake, or Loaf of Bread.

5. The *Romans* into the hilt or scabard of a Sword.

6. The *Persians* used to fix them to Arrows, and shoot them to places appointed near hand.

7. *Toroſthanes* by a Pigeon, stained with Purple, gave notice of his Victory at the Olympick Games, to his Father in *Aegina*, the same day that he obtained it. And this way of conveyance by Pigeons at great distances is of wonderful Celerity: For in *Aleppo* they have Pigeons which will fly (with Letters fixed to their Legs, or about their Necks) from *Babylon* to *Aleppo* in 48 hours, which is accounted 30 days journey. The manner of tuting their Pigeons is this: They take them when they sit on their Nests, transporting them in open Cages, and return them with Letters; who will never give rest to their Wings until they come to their Young. But let this suffice for some of the ways used by the Antients, I will proceed now to more Artificial ways of effecting the same.

I. By the 24 Common Letters of the Alphabet.

THE Letters of the Alphabet, by which you would represent your Mind to your Correspondent, may be so disposed in the form of a Right Angled *Parallelogram* (with any Number of *Cyphers*, *Intervals*, or (rather) *superfluous Letters* between every significant Letter;) so that the Writing may be read by your Correspondent any of these ways, which of them shall be agreed upon between you; As,

1	}	Descending with 4 intervals.	}	As in Example.	I		
2		Ascending with 3 intervals.			II		
3		Descending and Ascending alternately 2 inter.			III		
4		Ascending and Descending alternately 5 inter.			IV		
		Or,					
5	}	Direct with 7 intervals.			}	As in Example.	V
6		Retrograde 5 intervals.					VI
7		Direct and Retrograde alternately 2 Inter.					VII
8		Retrograde and direct alternately 3 inter.	VIII				

Example I.

Suppose that I would write to my Correspondent these Words,
Your Uncle is now Dead.

Wherefore I write it in *Upright Columns* descending, with 4 *Intervals*: (Which my Correspondent is supposed to know:) Wherefore I first make 4 Pricks, one under another, and under them I make the first Letter of my intended Writing [*y*], under that four Pricks more, and under them the next Letter [*o*], then two Pricks under, and (because your Column will hold no more Pricks below) two above in the next Column, and under them [*n*]; &c. As in the *Parallelogram* following.

Points

.	.	u	a	s	r	U	s	a	k	t	a
.	.	.	.	t	.	.	.	g	g	b	i	i	r	r	s
.	.	u	.	.	.	d	.	b	u	r	d	b	l	d	t
.	.	.	.	l	.	.	.	c	l	y	l	d	m	m	a
y	y	o	x	o	c	o	s	l
.	.	n	d	l	m	n	q	f	q	g	d
.	.	.	.	s	.	.	<i>etc</i>	f	y	t	s	s	r	y	<i>etc</i>
.	r	e	.	t	r	p	b	e	g	e	m
.	.	.	e	f	g	o	e	g	b	p	o
o	w	.	.	o	q	g	m	i	w	l	n
.	.	c	m	o	c	y	h	l	g	t
.	.	.	.	n	.	.	.	b	l	m	t	n	s	q	v

Points made for the Intervals. Superfluous Letters to supply the Intervals.

I have been somewhat large in this, but it is because I will give *Examples* in all the rest, but not in a double Nature, as I have done here, with *Points* only to supply the superfluous Letters.

Example II.

Passé from London, for you are betrayed.

Upright Columns Ascending, with 3 Intervals.

.	.	.	o	.	.	.	a
.	.	o	.	.	.	y	.	.	.	y
.	c	.	.	.	f	.	.	.	t
a	.	.	.	d	.	.	.	e	.	.	<i>etc</i>
.	.	.	L	.	.	.	u	d	.	.	.
.	.	r	.	.	.	r	.	.	.	a
.	r	.	.	.	n	.	.	.	e
h	.	.	.	n	.	.	.	r
.	.	.	m	.	.	.	o	e	.	.	.
.	.	f	.	.	.	o	.	.	.	r
.	s	.	.	.	o	.	.	.	b

RECREATIONS

Example III.

Your Castle will this Night be Surrendered to the Enemy by your own Souldiers.

Descending and Ascending Alternately, with 2 Intervals.

.	t	.	i	.	c	.	r	.	c	.	o	.	u	.	.
.
y	.	l	.	s	.	f	.	c	.	n	.	u	.	l	.
.	f	.	h	.	b	.	d	.	c	.	y	.	o	.	.
.
o	.	c	.	n	.	u	.	d	.	e	.	r	.	d	etc
.	a	.	t	.	t	.	n	.	h	.	y	.	f	.	s
.
u	.	w	.	i	.	r	.	t	.	m	.	o	.	i	.
.	c	.	l	.	h	.	e	.	t	.	b	.	n	.	r
.
r	.	i	.	g	.	r	.	o	.	y	.	w	.	e	.

Example IV.

The Blow is given by Tom.

Ascending and Descending alternately, with five Intervals.

.	o	e
T	i	b	.	.	.
.	.	.	B	i	o
.	.	e	g	T	.
.	h	s	y	.	etc
.	.	.	.	l	v	m
.	w	n

Example

CRYPTOGRAPHICAL 5

Example V.
Our provision is at an end.

Horizontal direct, with seven Intervals.

.	O	u
.	r	P	r	.	.
.	.	.	o	v	i	.
.	s	i	o
.	n	i
.	s	a	t	.	.
.	.	.	a	n	e	.
.	n	d	etc

Example VI.
If we are not Relieved this Day, we must Surrender.

Horizontal, but Retrograde, with 5 Intervals.

.	.	.	w	f	l
.	c	r	a	.	.	e
.	.	.	t	o	h	.	.	.	R
.	i	l	e	.	.	.
.	.	.	c	v	d
.	h	r	.	.	.
.	.	.	a	d	s
.	B	e	w	.	.	.	y
.	.	.	r	f
.	r	u	.	.	.	S
.	.	.	d	n
.	e
.	etc	r

E

Example

RECREATIONS

Example VII.

Our Victuals and Ammunition are both at an end.

Direct and Retrograde alternately, 2 Intervals.

.	.	O	.	.	u	.	.	r	.	.	V	.	.	i	.	.	c	.	.
.	n	.	.	a	.	.	s	.	.	l	.	.	a	.	.	u	.	.	t
.	d	.	.	A	.	.	m	.	.	u	.	.	n	.	.	i	.	.	t
.	.	e	.	.	r	.	.	a	.	.	n	.	.	o	.	.	i	.	.
b	.	.	o	.	.	t	.	.	h	.	.	a	.	.	t	.	.	a	.
.	Ec	d	.	.	n	.	.	e	.	.	n	.

Example VIII.

Your Brother James hath betrayed you.

Horizontal, Retrograde and Direct, alternately, with 3 Intervals.

.	.	.	u	.	.	.	o	.	.	.	Y	.	.	.
r	.	.	.	B	.	.	.	r	.	.	.	o	.	.
.	r	.	.	.	e	.	.	.	h	.	.	.	t	.
.	.	J	.	.	.	a	.	.	.	m	.	.	.	e
.	.	.	a	.	.	.	h	.	.	.	s	.	.	.
t	.	.	.	h	.	.	.	b	.	.	.	e	.	.
.	y	.	.	.	a	.	.	.	r	.	.	.	t	.
.	.	e	.	.	.	d	.	.	.	y	.	.	.	o
.	Ec	u

In all these ways may *secret Writing* be written and read in a *Parallelogram*: But the *Figure* may be any other, as a *Triangle*, *Rhombus*, &c. and to be read *Diagonally*, either *Ascending* or *Descending*, or both alternately; as in these *Figures* following.

Example

Example IX.

Fly For the Cotton will be fired in three places.

In a Triangle Diagonally Ascending, with 2 Intervals.

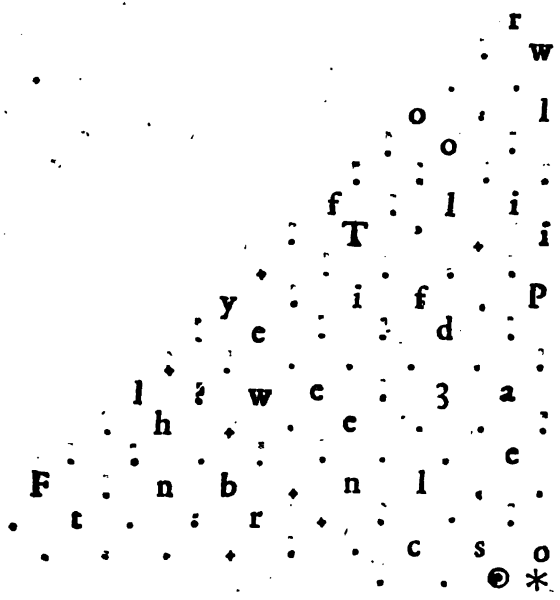

II. By Transposing of the Letters of the Alphabet.

Julius Caesar, when he communicated his mind to his Correspondent (to whom he had before declared his manner of Writing,) he did it by this way of Transposition, putting D, the fourth Letter, for A, the first Letter of the Alphabet; and so throughout the whole Alphabet, as in this Scheme, which will serve for a Clavis to unlock secret Matter written according to this Transposition, which may be varied Millions of ways.

The Scheme, or Clavis.

a	b	c	d	e	f	g	h	i	k	l	m	n	o	p	q	r	f	t	v	w	x	y	z
d	e	f	g	h	i	k	l	m	n	o	p	q	r	s	t	u	w	x	y	z	a	b	c

The Scheme thus prepared, and the Correspondent knowing the Order of Transposition, Suppose that I would write these words; To be read in Upright Columbs Descending:

As you tender your own safety get out of Italy, and repair to Paris with what speed you can.

D	g	z	k	M	v	S	l	b
w	h	q	h	x	h	d	z	g
b	v	w	x	d	s	v	l	b
r	b	d	r	o	d	m	d	r
y	r	i	y	b	m	w	x	y
x	y	h	x	d	v	z	w	f
h	v	x	r	q	x	m	s	d
q	r	b	i	g	r	x	h	q

Now by this *Clavis* (or any other *Transposition* (or varying) of the Letters of the Alphabet) you may frame your *Writing* to be read any of the former ways, as *Downwards*, *Upwards*, *Direct*, *Retrograde*, *Diagonal*, &c..

But this way (in my judgment) for Secrecy, is more liable to be discovered (if intercepted) than the former ways, by supplying Intervals by (any number of) superfluous Letters; for that in this way there are no more Letters used than will be required to make out the Words intended; which makes it very liable to discovery: Wherefore I shall in the next place shew a way whereby to use other Characters instead of the Letters of the Alphabet; with Intervals of a different Character interposed.

III. By Other Characters, which shall Represent the 24 Letters of the Alphabet.

NOT to invent new, strange, and insignificant Characters, such as your Stenographers, or Short-Hand Writers use; I shall here present you with an Alphabet of known Characters; viz. with those of the *Astronomical Signs, Planets and Aspects*; Whereof the *Twelve Signs, the Seven Planets, and the Five Aspects* together makes Twenty Four, equal to the Number of the Letters of the Alphabet. And of these let the five *Aspects* represent the five *Vowels*, {^a ♂ ^e ♀ ⁱ ☐ ^o △ ^u * } And let the Characters of the *Seven Planets* represent the Letters towards the beginning of the Alphabet: And the Characters of the *12 Signs* the Letters towards the end of the Alphabet; as in the following *Scheme, or Astronomical Clavis*.

The Astronomical Clavis.

a	b	c	d	e	f	g	h	i	k	l	m	n	o	p	q	r	s	t	u	w	x	y	z
♄	♃	♂	♆	♁	♅	♁	♃	♁	♄	♃	♂	♁	♁	♁	♁	♁	♁	♁	♁	♁	♁	♁	♁

The Key being thus agreed upon between you and your Correspondent, it will be very easie to communicate your mind to him in any of the forementioned Methods, viz. by *Parallelogram, Triangle, &c.* And

CRYPTOGRAPHICAL 9

And so supposing you would write to your *Correspondent*, to be read in a *Parallelogram Descending and Ascending alternately*; and at the end of every Word (for distinction) to interpose some one of the *Nine Digits, viz. 1, 2, 3, 4, 5, 6, 7, 8, or 9*, and at the close of all this *Character* ⊕.

Suppose you would write these Words, to be read in *Columns Descending and Ascending alternately*, with a *Digit Figure* between each Word, and at the End ⊕.

I have escaped out of the Castle in Disguise, and do lodge at the Hall in the High Street, by the Name of Mary Grice,

□	♂	5	♀	♂	□	≡	4	γ	h	♂	♀	♀	♂	≡	7	
7	♂	Δ	∩	7	♂	♀	Δ	Δ	4	γ	♂	5	∩	4	∩	♀
♀	⊕	*	3	γ	4	*	♂	♂	♂	γ	♀	≡	8	∩	♂	∩
♂	♂	∩	⊙	♂	∩	□	5	♀	♀	7	6	∩	≡	♂	♂	□
*	γ	4	Δ	≡	□	≡	♂	♂	∩	□	♂	∩	h	♀	6	γ
♂	≡	Δ	6	∩	5	♂	∩	3	5	∩	♀	♂	4	♂	⊙	♂
3	♂	*	∩	γ	♂	7	♂	♂	∩	5	∩	♂	∩	4	Δ	⊕

This way of Writing is far more difficult to be discovered than the former by Letters only, though as much, or more to be suspected when intercepted. Let your Writing be in any Language, it may be by these Characters expressed, and in any form: As suppose I would write this *French Proverb*, in a *Rhomboides* form, to be read in a *Diagonal Descending and Ascending alternately*:

Pape par voix, Roy par nature, Empereur par force:

		⊕	□	γ	♂	∩	*	∩	
		♂	Δ	5	∩	*	♂	♂	
		⊕	*	∩	γ	∩	∩	⊕	
		♂	4	Δ	∩	♂	♂	∩	
		7	∩	≡	♂	6	⊕	Δ	
		⊕	♂	4	⊕	♂	♂	3	⊙

IV. By Knots tyed (or other Marks made) upon a String.

FOR the effecting of this, the *Two Correspondents* must each of them have a fine thin Board, or piece of Brals, or Copper, made in the form of a *Parallelogram*, or *Long Square*; at one end whereof let be written or engraven the *Twenty Four Letters* of the Alphabet, either in order, or transposed, which shall be agreed upon; and between each Letter, let there be a faint or occult Line drawn or ganged quite through the Board, or Plate, from end to end, representing *Twenty Four Columns*: Also, let the *Two longer sides* of the Board, or Plate, have *Notches* cut in it, at about one quarter of an Inch distance from each other; as in the Figure is expressed.

The

The Figure of the Board or Plate, with the Alphabet.

a, b, c, d, e, &c.



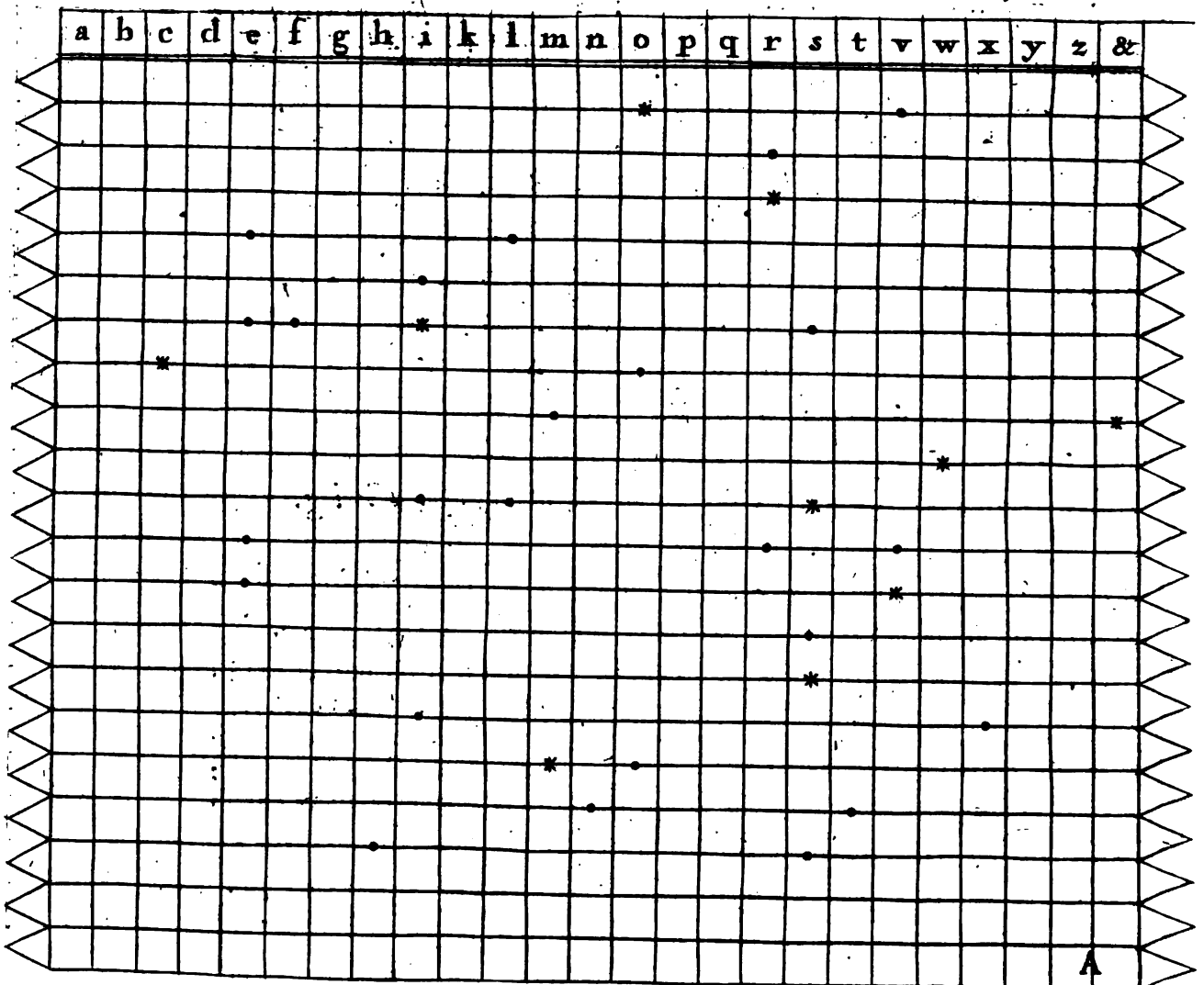

When you would communicate your mind to your Correspondent, take a Piece of even and well-twisted Packthread, at one end whereof tie a Noose to be put over an Hook towards the top of the Board on the back side thereof, made for that purpose. Then bring the *String* over at *a*, and bring it to the Notch *b*, and from *b*, over at *c*, and guide it to *d*, and so continue till you have as many Lines of String as will contain your intended Writing. The *Board*, and *String* being thus prepared, suppose you would express these Words,

Our Relief is come, and will serbe us Six Months.

Upon the *String*, under the Letter *o*, tie a Knot, or (rather) with a Needle, and some light coloured Thread, or Silk, stich through that part of the *String* which lies under *o*; do the like under *u*, and in the next line under *r*, so have you your first word *Our* expressed upon the *String*. And doing so with all the rest, you will find the *Knots* or *Marks* upon the *String* when it is upon the *Board* or *Plate*, as in the *Figure*: Which being taken off, and conveyed to your *Correspondent* (who knows well enough how to apply it to his *Board*) it will declare your Writing very plainly, and void of all suspicion, if intercepted.

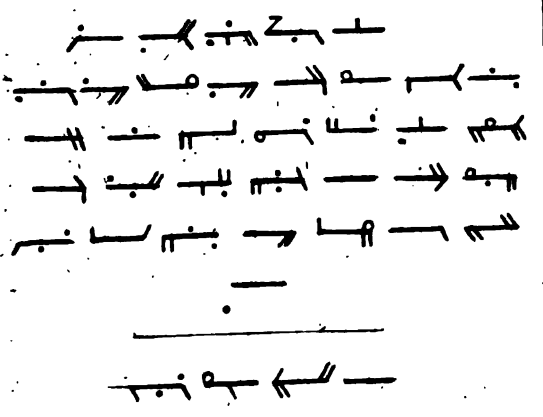

A NEW CHARACTER *Easie* to Learn and Write, difficult for a Stranger to decipher, Legible by the Motion of the Fingers, wherein each Line of Writing shall contain Two Lines of Sense.

<i>An Alphabet of the First Forme.</i>		} <i>The Ground Line.</i> —																					
a	b	c	d	e	f	g	h	i	k	l	m	n	o	p	q	r	s	t	v	w	x	y	z
<i>Or thus</i>																							
·	·	·	·	·	·	·	·	·	·	·	·	·	·	·	·	·	·	·	·	·	·	·	·
/	/	/	/	/	/	/	/	/	/	/	/	/	/	/	/	/	/	/	/	/	/	/	/
\	\	\	\	\	\	\	\	\	\	\	\	\	\	\	\	\	\	\	\	\	\	\	\
=	=	=	=	=	=	=	=	=	=	=	=	=	=	=	=	=	=	=	=	=	=	=	=
>	>	>	>	>	>	>	>	>	>	>	>	>	>	>	>	>	>	>	>	>	>	>	>
<i>An Alphabet of the Second Forme.</i>		<i>An EXAMPLE</i>																					
·	A	E	I	<div style="display: flex; justify-content: space-between;"> <div style="width: 45%;"> <p><i>A New Character</i> <i>Easy to learn and write</i> <i>difficult for a Stranger</i> <i>to decipher legible</i> <i>by the Fingers.</i></p> </div> <div style="width: 50%;">  </div> </div>																			
·	O	V	Y																				
	B	C	D																				
	F	G																					
/	H	K	L																				
\	M	N																					
\	P	Q	R																				
=	S	T																					
>	W	X	Z																				
<div style="display: flex; justify-content: space-around; align-items: center;"> <div style="text-align: center;">  <p>B</p> </div> <div style="text-align: center;">  <p>N</p> </div> <div style="text-align: center;">  <p>A</p> </div> <div style="text-align: center;">  <p>O</p> </div> </div>																							

EVERY Letter of this Alphabet is built upon a short line, thus (—), which, for distinction sake, may be called *the Ground-Line*. The several letters are formed by the addition of a few small strokes, or points, which represent divers letters, according as they stand at the *Beginning, Middle, or End of the Ground-Line*.

I have given the Alphabet in Two Forms; The first as plainer to be understood; the second Form as easier to be remembered. At the Top of

of the second Alphabet you have a *Point*, or *Speck*, and the letters A E I, which denotes, that a *Point* at the *Beginning* of the *Ground line* (either above it, or under it) stands for A, the first Letter of the Three. If the *Point* be over (or under) the *Middle* of the *Ground Line*, it is E, the middle Letter; and if over (or under) the *End*, it is I, the third letter at the *Right Hand*. So in the middle Rank is (!) H K L, which shews that this oblique stroke (!) set at the *Beginning* of the *Ground-Line*, is H, at the *Middle* K, at the *End* L; and so of the rest.

That your Writing may look more gracefully, let all your *Ground-Lines* be at equal distances from each other; and when you end a word leave one line blank, as you will see in the Example annex.

It will oft fall out, that Two, and sometimes Three Letters, may be express successively upon one side of the *Ground-Line*, viz. when after a Letter, whose place is at the *Beginning*; another follows immediately, whose place is in the *Middle*, or *End* of the *Ground-Line*, as you will find in the Syllable *be, ben, fu, fun, wet, &c.* which Syllables rightly written, will seem but one Letter.

When you have written a Line on the *upper side* of your *Ground-Line*, begin again on the *under side*, and go on with your matter; so will every Line be *double written*; which will take up less room than other Writing, and render it very difficult to be deciphered.

Instead of more Directions there is an Example in the Scheme foregoing, which follows.

AN EXAMPLE.

The Character has a farther Conveniency, that it may be read or express to another person by the *Motion of the Fingers*, the Letters being so framed that they may be easily so express, thus, Let the *fore-finger* of your *left hand* represent the *Ground-line*. Let the *root* of the *Finger* represent the *beginning of the Line*, the *middle joynt*, the *middle of the Line*, and the *tip of the Finger*, the *end of the Line*; The several letters are formed by putting the *Fingers* of the *right-hand* upon this *ground-finger* in such manner as shall represent the Letter. So B is express by putting your *right-hand fore-finger* perpendicularly on the *root* of the *left-hand fore-finger*. N. is express by putting the two *foremost fingers* of the *right-hand* obliquely on the *tip* of the *left-hand fore-finger*. See the figure.

A E and I are express by laying the *End* of the *Right Fore-Finger* in the *Root*, *Middle* and *End* of the *Left Fore-Finger*, both *Fingers* lying level, as in the *Figure* at A.

O U and Y are formed by joyning the *Tips* of your *Right Fore-Finger* and *Thumb*, so as to make a kind of O, which being set at *Beginning*, *Middle* and *End*, is either O, U or Y; as — W X Z are made by crooking, or bending your *Right Fore-Finger*, to imitate the crooked stroke for those Letters.

When you come to the *End* of a word, you may give a *Fillip* with your *Finger*, to intimate as much. By this means Two Persons may talk to each other without being heard or understood by *By-standers*.

Note, If you would have this way of Writing peculiar to your self, so as that others, who have seen this Alphabet, may not read it, you may if you please, alter the Alphabet, by making the additional strokes, &c. stand for other letters than here they are put for. Some

Some other ways of Secret Writing.

I. IF you take some *Salmonack*, beaten to Powder, and steeped in *Vinegar*, and write what you please therewith upon White Paper, letting it be thorough dry, and nothing will be discerned; but hold the Paper a little while against the Fire, and you shall see all that was written, as black as if it had been written with Ink-----If you write with the Juice of *Limon* it will do the same.

II. Take good *Roach-Album*, and boyl (or dissolve) it in fair Water till it be very strong, then write therewith upon *Vences* or (thin Paper) what you please, so that when it is thorough dry, nothing will be seen: But take the written Paper, and draw it through a Basin of fair Water, till it be thoroughly wet, and then what you writ will appear as if it were writen with White upon the wet Paper.

III. If you write with *Urine*, *Milk*, or such other Glutinous Moisture, and when it is dry, throw fine Ashes or Dust thereupon, rubbing softly upon the Writing, the Words or Letters will appear-----Also if you write upon the Back of your Hand (or any part of your Body) with *Urine*, take some Paper and burn it, and with the Ashes of the Paper rub the Writing over, and it will be very legible upon your Hand or Body.

RECREATIONS

Magnetical.

CHAP. I.

Of the Magnet or Load-stone; And of Experiments performed thereby.

I. Of the Name.

IT is called *Load-stone*, or a *Leading Stone*, *est enim Lapis cujus ducto nauta cursum institunt* : In the *German* Tongue it is called *Seil-Stein* : In *Low-Dutch*, *Segel-Stein* : i. e. *Lapis Navigationes*. *Magnet-Stein* : In *French* *Aimant* : In *Spanish* *Ymán* : In *Italian*, *Magneté*, *Magnesia* : In *Latin* *Magnes*, *Magnesium* : In *Greek* $\mu\alpha\gamma\eta\eta\sigma\iota\varsigma$, & *Magnete Inventore*. But *Lucretius* writeth that its name is Derived from the *Countrey Magnesia* :

The *Greeks* do call it *Magnes* from the *Place* ;
For that the *Magnets* Land it did Embrace.

Plato saith, some call it *Lapis Heraclius*, from the Name of *Heraclia*, a City of *Lydia*, where it was first discovered ; and upon the same account the *Touch-stone* is called *Lapis Lydia*. *Theophrastes* calleth it *Herculeum* for the same Reason ; and others take it from *Hercules* : *Nican-der* and *Pliny*, think it so called from one *Magnes*, a *Shepherd* ; for it is reported that he found it by chance, his *Hob-nail'd Shooes* and *Crook*, sticking fast to it, as he was feeding his *Flock* in *India*. Others call it *Siderites*, which in *Greek* signifies *Iron*. By us it is called *Load-stone*, aluding to the *Two Stars* in the *Tail of the Celestial Bear*, called *Helice* and *Cynosma*, which were anciently called the *Load-stars*, or *Leading-Stars* ; and this *Stone* performing the Office of those *Stars*, taketh its Name of *Lead*, or *Load-stone*.

II. Where

II. *Where these Stones are found, and of their Colour, Weight and Force.*

They are found in divers parts of the World, and most commonly in *Iron-Mynes*: Of them there are divers sorts, differing one from another in *Colour, Weight, and Force* in attraction; but all of them agree in *Property*.

1. The best of these *Stones* come out of *East India*, from the Coasts of *China* and *Belgana*. They are of an *Iron, or Sanguine Colour, Massy and Weighty*. Some of them will attract, or lift up not much above their own weight, but others (well *Capt* and ordered) will take up five, ten, and some twenty times their own weight; and these (being but rarely found) are sold for their weight in *Silver* in *India*, where they grow.

2. There are some found in *Arabia*, and *the Red Sea*, which grow broad and flat, like a *Paving-Tile*. They are of a *Reddish Colour*, and are not so weighty as those which grow in *China*, but their *Vertue* near as good, and will continue long upon a *Needle* touched on them.

3. Some of these *Stones* are found in the *Levant*, in the Island called *Elba*, near *Parta Ferraro*, and are there called *Calamita Preta*, or *Black Magnets*; These have no great *Force*, neither doth the *Vertue* they infuse last long.

4. There are others of a *White Colour*, and spongy, like an *Honey-Comb*, found in *High Albany*; they are lighter, but their *Vertue* is stronger than the *Black ones* before spoken of.

5. Of these *Stones* some are found at *Long-sound*, in the *Iron-Mines* in *Norway*, their *Colour Black*, mixed with *Grey*, but of an indifferent *Force*.

6. Some there are found in the *Mines* of *Carraca*, and *Cantabria*, in *Spain*; Others in *Bohemia*; and some in the *West* of *England*.

CHAP. II.

That the whole Globe of the Earth hath true Magnetical Vertue; Proved by Experiment.

1. TAKE any Piece of *solid Earth*, that hath some toughness to hold together, and will abide the *Fire* (as *Brick*, or *Tobaccopipe-Clay*) fashion it in such sort that it be uniformly extended towards both ends (the *Oval Figure* will be very fit for this purpose) put it into a *Charcole Fire*, increasing the *Heat* by little and little, and with often blowing make it thoroughly red hot; Let it remain so for half an hour or more, that all superfluous moisture, and adverse qualities may thereby be consumed and separated from it: Then take it forth, and let it cool of itself, being laid upon a *Meridian-line* first drawn upon a *Free-Stone* elevated according

to the Latitude of the place : And then it is certain, that this piece of *Earth* thus ordered, will sensibly shew you that it hath *true Magnetical Vertue*. For one end of a *Magnetical Needle* will covet towards one end of this prepared *Mass* of *Earth*, and fly from the other : And that End which cooled toward *the South*, will draw the *true North End* of the *Needle*; and that end which cooled towards *the North*, will draw the *true South end* of the *Needle*. And for a farther infallible argument, do thus: Mark (with a piece of Chalk, or the like) what end of *the Mass* drew *the North* end of *the Needle*, and put it into the Fire again; and when it hath been glowing hot half a quarter of an hour, take it out and cool it, being placed with that marked end towards the *North*; and that end now will draw *the South* end of *the Needle*, and *the North* end of *the Needle* will shun it, which before approached unto it.

C H A P. III.

That Magnetical Vertue may be infused into a Needle, without the help of a Load-Stone.

IRon being a Mineral of *the Earth*, and having a Sympathetical Quality with *the Loadstone*, acquiring this Verticity from *the Magnetism* of the *Earth*; as in Bars of Windows which have been of long continuance: Take such a Bar, and file both the ends thereof very smooth; then take a small *Needle*, and touch it thereupon, the *South* end of *the Needle* upon *the North* (or upper) end of the Bar, and *the North* end of the *Needle* upon the *South* (or lower) end of the Bar: Such a *Needle* you will find to have respect, and conform it self to *the magnetical Meridian* of the *Earth*.

C H A P. IV.

Of the Attractive Vertue of the Loadstone.

1. **I**F you apply a piece of *Iron* to either of the *Poles* of a *Load-stone*, it will here hold it, and at a distance will also draw, or attract a small piece of *Iron*, according to the Vigor or Indebility of the Stone.
2. Whatsoever strength a *Stone* hath, it may be artificially improved to be greater, by applying two smooth and bright pieces of *Iron* to either *Pole* of the *Stone*, unto which *Irons*, the *Stone* will immediately impart its *Vigour*; And the *Stone* by this means will become far more vigorous than it was before these *Irons* were applied to its *Poles*, and bound thereto by *Brass Hoops* or *Bands*, which is called *Capping* of a *Load-stone*.

3. A Piece of *Steel* having received strength from the *Stone*, that will also attract another piece of *Steel* to it, in proportion as the Virtue the first piece hath received from the *Stone*. For if you touch a *Knife* (being clean) upon the *Stone*, that *Knife* shall take up a *Key*, or other bright piece of *Iron* of two *Ounces* weight: And that within the *Sphere* of the *Stones* activity, shall deliver the virtue into another piece of *Iron*, causing the two pieces of *Iron* to hang one to another.

C H A P. V.

Of the Sympathetical and Antipathetical Property of the Load-Stone.

1. **W**hen a *Needle* is touched upon a *Load-Stone*, the *North* and *South* ends of this *Needle* will apply themselves to the *Poles* from whence they received their *Magnetical Life*, viz. the *North* end of the *Needle* to the *North* end of the *Stone*, and the *South* end of the *Needle* to the *South* end of the *Stone*; which denotes their mutual *Sympathy*:

2. But putting the *North* end of the *Stone*, to the *South* end of the *Needle*, when it hangs upon a *Pin*, the *South* end of the *Needle* will immediately fly away; and if you put the *South* end of the *Stone*, to the *North* end of the *Needle*, it will there discover the *Antipathetical Nature*; for it will fly away from it.

3. But a contrary *Operation* there is yet in the two *Needles* to that of the *Stone*: For if one of the *Needles* being hung upon a *Pin*, if you apply the *North* end of the other *Needle*, to the *North* end of that upon the *Pin*, it shall immediately fly away, which denotes a contrary *operation* in the *Needle*, to that of the *Stone*; and the *South* end of the one, will come to the *North* end of the other.

4. The same Property of *Sympathetical Coition*, and *Antipathetical Repulsion*, may be also discovered by two *Load-stones*, floating in two little Boats in a *Bason* of *Water*, the two *Poles* of either *Stone* being disposed parallel to the *Horizon*: And if you put the two *South-Poles* together, they shall avoid the contact of one another by a natural *Antipathy*; But if the *North-Pole* of one, be direct to the *South-Pole* of the other, they will immediately manifest their natural *Sympathy* one to another, and will cleave together by a strong attraction.

5. This is also evident between the great *Magnet* the *Earth*, and a *Load-stone*; For if you put a *Load-stone* in a *string*, and hang it up in the *Air*; or to float in the *Water* in a *Wooden-Dish*, and putting the *North* end of the *Small-Magnet*, towards the *North* of the *Great-Magnet* the *Earth*, it shall immediately change its Position, and turn its *North-Pole* towards the *South-Pole* of the *Great Magnet*.

C H A P. VI.

Several Consequencies which follow the various Cutting, or Dividing of a Load-Stone.

1. **I**F a *Load-stone* be casually broken into several *pieces*, every *piece* shall be an entire *Load-stone*; having both its *Poles* distinctly in it self, with all the other properties which the other *Load-stone* had before it was broken.

2. But if a *Load-stone* be divided in the middle, between the two *Poles*, that is in the *Equinoctial*, then is it absolutely two entire *Load-stones*; but those parts which were the *Equinoctial* before, are now become two *Poles*; and the two *Poles* that were the two *Poles* before, continue to be two *Poles* still.

3. But if a *Load-stone* be cut through a *Meridian*, and consequently through both the *Poles* thereof; so that one *Axis* is now converted into two, and each of them remove into each *Stone* one: And so it is become two absolute *Load-stones*, and the *Axis* of either of them will retire into the gravity of each part: And if you joyn the two pieces together again, the two *Axes* will again become one.

4. But if you cut off a piece of a *Stone* at the very *Pole*, in a parallel Section, the *Virtue* of that *piece* cut off will immediately retire from it into the main *Stone*, and will have little or no virtue in it; but applying the small piece cut off, to the same place again, the *Stone* will forthwith impart the same virtue as was before into this piece so cut off, so long as it doth abide in that place; but when it is removed, it doth again lose its virtue.

5. Likewise, If you apply a *Weak Stone* to the *Poles* of a *Strong one*; the *Strong Stone* will impart of his *Virtue* to the *Weak Stone*, making it to be as strong as it self, so long as it is his Neighbour; but when this weak *Magnet* deserts this Neighbourly Propinquity, the strong *Magnet* will draw its *Virtue* to it self again.

C H A P. VII.

How to find the Poles of a Loadstone.

1. **T**AKE a thin piece of *Steel*, about an Inch in length, and a quarter of an Inch broad: This piece of *Steel* being bent Circular, and laid upon the *Stone*, will immediately lye parallel to the *Axis* of the *Stone*; and direct which way the *Poles* do lye. Which being thus far discovered, you may find them exactly thus. Take a piece of a common sewing *Needle*, which being laid upon the *Stone* near either of the *Poles*,

Poles, it will elevate one end thereof, then move it farther and farther, till it do erect it self *perpendicular*, and that very Point will be the *Pole* of the *Stone*.—And now to know which *Pole* it is that you have found, apply a *Needle* that hath been touched, and if the *Stone* draw the *North* end of the *Needle* to it, then is that the *North Pole* of the *Stone*; but if the *South* end be drawn, the contrary.—Otherwise, you may find the *Pole* of a *Stone* in this manner; Take a common *sewing Needle*, and thred it, then hang it over the *Stone* where you imagine the *Pole* to be, and keep the Point a little short from the *Stone*, and the *Needle* will point *directly* to the *Pole* of the *Stone*.

2. If you take a small *sewing Needle*, and touch the two ends thereof upon the two *Poles* of the *Load-stone*; then having a *Glass of Water*, lay the *Needle* gently upon the *superficies* of the *Water*, and it will there *swim*. Then take a *Knife* that hath been touched with a *Load-stone*, and move it too and fro upon the edge of the *Glass*, and the *Needle* will follow it up and down, and will play upon the *superficies* of the *Water*, as a *Fish*; then take away the *Knife*, and the *Needle* will rest upon the *Water*, and in a situation *North* and *South*.

3. If you take two *sewing Needles* touched, and put the Point of one *Northerly*, and the Point of the other *Southerly*, and put them into two small pieces of *Cork*, and put them thus into a *Basin of Water*, one on one side, and the other on the other side of the *Basin*, you shall see them as it were quickened with a vital spirit, even so to move one towards another, at the first softly, but when they draw nearer, they will rush together with great violence; the Point of the one striking exactly against the Point of the other.

4. If you take a good large *Brass* or *Pewter Plate*, and upon it place some *filings* of *Steel* or *Iron*; and some small *bits* of *sewing Needles*, and disperse them about the *Plate* in several places; Then take a *Load-stone*, and put it under the *Plate*, with one of the *Poles* upwards, and put it sometimes to one *heap*, and sometimes to another, so shall you find them *heaps* to interfere, and clash one against another, being very pleasant to behold.

C H A P. VIII.

Of several Attempts that have been made to contrive a Perpetual Motion by Magnetical Virtues.

IT was the Opinion of *Peter Peregrinus*, That a *Magnetical Globe*, or *Terella*, being rightly placed, upon its *Poles*, would of its self have a constant *Rotation*, like the *Diurnal motion* of the *Earth*: But this his Opinion is generally exploded, by common experience.

Athanasius Kirkerus thinks it possible to contrive several pieces of *Steel* and a *Load-stone*, that by their continual *Attraction* and *Expulsion* of one another, they may cause a perpetual *Revolution* of a *Wheel*; and of this Opinion were *Peter Peregrinus* above mentioned, *Cardan* and others: But *Dr. Gilbert* concludes it to be a vain and groundless fancy.

Of

Of these kind of Inventions, this which follows is the most likely, wherein a *Load-stone* is so disposed, that it shall draw unto it, upon a *Reclining Plain*, a *Bullet of Steel*; which *Steel*, as it ascends near to the *Load-stone*, may be contrived to fall down into a hole in the *Plain*, and so to return unto the place from whence at first it began to move; And being there, the *Load-stone* will again *Attract* it upwards, till coming to this *Hole*, it will fall down again; and so the *Motion* shall be *perpetual*, as may be conceived by this Figure :

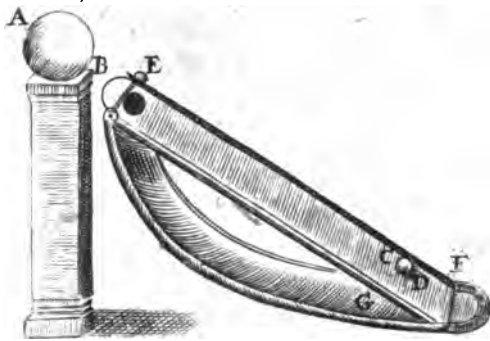

Wherein suppose the *Load-stone* to be represented at *A B*, which though it hath not strength enough to *attract* the *Bullet C* directly from the *Ground*, yet may do it by help of the *Plain E F*. Now, when the *Bullet* is come to the top of this *Plain*, its own *Gravity* (which is supposed to exceed the strength of the *Load-stone*) will make it fall into the *hole* at *E*; and the force it receives in this fall, will carry it with such a violence unto the other end of this *Arch*, till it will open the *Passage* there made for it, and by its return will again shut it; so that the *Bullet* (as at the first) is in the same place whence it was first *Attracted*, and consequently must move *perpetually*.

But this *Invention*, tho' it have such strong probability in it, yet there are some particulars which may render it insufficient.

C H A P. IX.

Of Magnetical Inclination, or of the Inclinary (or Dipping) Needle: And thereby to find the Latitude at Sea or Land, without help of the Sun or Stars.

OF the Mariners *Plain Compass* I shall say nothing, it being so well known to all Persons: But of this *Inclinary (or Dipping) Needle* much hath not been said; But it was the useful Invention of Dr. Barlow, Physician in Ordinary to Q. Elizabeth: Also written upon by Dr. Gilbert, Dr. Ridley, and Mr. Edward Wright, who hath a *Geometrical Demonstration* of the Natural Reason thereof; and lastly by Mr. Henry Bond, who hath applied it to the finding of the *Longitude* as well as the *Latitude*.

This Instrument is now contrived so, as to hang in a broad *Brass Ring*, within two *Glasses*, to keep the *Needle* from the *Air*: In the *Brass Ring* are two *Quadrants* divided into 90 *Deg.* and the *Needle* hangs upon an *Axis*, playing upon two *Pevets*: And the Instrument hangs in a *Box* so ordered, that the Ship moving up and down, the Instrument hangs Perpendicular in respect of the *Ring*, and horizontal in respect of the *Box (or Compass)*.

The *Needle* in this *Brass Ring* between the two *Glasses* (before it is touched with the *Load-stone*) is made to hang upon its *Axis* *Horizontally*; but when it is touched it hath an *Inclination*, respecting a certain point of *Elevation* or *Depression*, according to the *Latitude* wherein it is at any time used: And the *Depressions* are such, in every degree of *Latitude*, as in his *Table* are exhibited.

G

A Table

RECREATIONS

A Table of Magnetical Inclination.

Latitude, Magne- tical In- clinati- on.	Latitude	Mag. &c.	Latitude	Mag. &c.	Latitude	Mag. &c.	Latitude	Mag. &c.	Latitude	Mag. &c.						
D D	M D	D	M D	D	M D	D	M D	D	M D	D	M					
12	11	16	30	45	31	52	27	46	68	24	61	79	29	76	86	28
24	20	17	32	24	32	53	41	47	69	17	62	80	47	77	86	48
36	27	18	34	0	33	54	53	48	70	9	63	80	38	78	87	8
48	31	19	35	36	34	56	44	49	70	59	64	81	11	79	87	26
510	34	20	37	9	35	57	13	50	71	48	65	81	43	80	87	44
612	34	21	38	41	36	58	21	51	72	36	66	82	13	81	88	1
714	32	22	40	11	37	59	28	52	73	23	67	82	43	82	88	17
816	28	23	41	39	38	60	33	53	74	8	68	83	12	83	88	33
918	22	24	43	6	39	61	37	54	74	52	69	83	40	84	88	47
1020	14	25	44	30	40	62	39	55	75	35	70	84	7	85	89	1
1122	4	26	45	54	41	63	40	56	76	17	71	84	32	86	89	14
1224	5	27	47	15	42	64	39	57	76	57	72	84	57	87	89	27
1325	38	28	48	36	43	65	38	58	77	37	73	85	21	88	89	39
1427	21	29	59	54	44	66	15	59	78	15	74	85	44	89	89	50
1529	4	30	51	11	45	67	30	60	78	52	75	86	79	90	90	00

The Use of the Table.

Suppose you were at Sea in an unknown Latitude, and would find it by this Instrument and Table.—Your Instrument being fitted, and the Fly in the Box, and the *Brass Ring* to hang directly *North* and *South*; Then look how much you find the *North* end of the *Needle* in the *Ring* to be depressed (which suppose to be *63 deg. 40 m.*) find these *degrees* and *minutes* in the *Table*, under the Title of [*Magnetical Inclination*] and against it you shall find *41 deg.* which tells that you are in *41 deg.* of *North Latitude*, because the *North* end of the *Needle* is depressed: For if the *South* end had been so much depressed, you had then been in *41 deg.* of *South Latitude*.

RECREATIONS

Chymical.

CHAP. I.

Of Artificial Representations.

THE Grounds and Principals of *Chymical Philosophy* go thus: That *Salt, Sulphur* and *Mercury* are the Principles into which all things do resolve; and that the Radical and Original Moisture whereby the first principle of *Salt* consisteth, cannot be consumed by *Calcination*; but the forcible Tinctures and Impressions of things, as *Colour, Taste, Smell*; nay, and *the very Forms themselves*, are invisibly kept in store in this firm and vital Principle. To make this good by Experiment, They take a *Rose, Julyflower*, or any kind of Plant whatsoever; they take this Principle in the Spring-time, in its fullest and most congruous consistence; they beat the whole Plant in a Mortar, Roots, Stalks, Leaves and all, till it be reduced to a confused Mass. Then after *Maceration, Fermentation, Separation*, and other workings of Art, there is extracted a kind of Ashes, or Salt including these Forms and Tinctures under their Powers and *Chaos*. These Ashes are put up into Glasses, written upon with the several Names of the Herbs or Plants; and sealed *Hermetically*; that is, the Mouths of the Glasses heated in the Fire, and then the Neck of it wrung about close; this they call the Seal of *Hermes* their Master. When you would see any of these Vegetables again, they apply a Candle, or soft Fire to the Glass, and you shall presently perceive the Herbs or Plants, by little and little to rise up again out of their Salt or Ashes, in their several proper forms, springing up as at first, they did in the Field or Garden (but in a shorter time.) But remove the Glass from the Fire, and they immediately return to their own *Chaos* again.

Now although this went for a great Secret in the time of *Quercetan*; yet *Gaffarell* saith, that now 'tis no such rare matter; for *Monfieur de Claves*, a most excellent Chymist of these days (and others) uses to make shew of them at any time.

C H A P. II.

To preserve Fire as long as you will, in imitation of the inextinguishable Fire of Vestales.

HAVING Extracted the Burning Spirit of the Salt of Jupiter, by the degrees of Fire, according to the Rules of *Chymistry*: The Fire being kindled of it self, break the *Limbeck*, and the Irons which are form'd at the bottom will flame, and appear as burning Coles, as soon as they feel the Air; the which Fire, if you promptly inclose in a Vial of Glass, and close it up with *Hermes Wax*, to prevent Air getting in; then will it keep Fire for a thousand years; yea, if it be kept under Water, or in a Cave, Vault or Cell: But if you open it and let in the Air, the Fire quickly ~~extinguishes~~.

C H A P. III.

To make the Philosophers Tree.

TAKE two Ounces of *Aqua fortis*, and dissolve it in half an Ounce of fine *Silver* refined in a *Cappel*: Then take one Ounce of *Aqua fortis*, and two Drachmes of *Quick-Silver*, which put in it, and mix these two dissolved things together; then cast it into a Vial of half a Pound of Spring Water; which must be well stopped: And then may you every day see it grow both in the *Tree* and in the *Branch*.

C H A P. IV.

Of the Re-animation of Simples, when (by reason of the great distance of Places) the Plants cannot be transported.

TAKE the *Simple, Root, Stalk and Branches*; Burn all and take the *Ashes* of it, which let be *Calcinated* two hours between two *Crensets*, well *Luted*, and extract the *Salt*; that is, to put Water into it in moving of it, then let it settle; and do it so two or three times: Afterwards *Evaporate* it, that is, let the Water be Boiled in some Vessel, until it be all consumed, and then there will remain a *Salt* at the bottom; which

which afterwards Sow in good Ground well prepared, and you shall have the Plant grow.

C H A P. V.

Of the making of the Epitomy (or representation) of the Great World.

Draw Salt Niter out of Salt Earth, digged on the Shores (if you can) where are Minerals of Gold and Silver; Mix this Niter (being first well cleaned) with Jupiter, and Calcine them *Hermetically*; then put it into a Limbeck, whose Receiver let be of Glas, and both well Luted together; but at the bottom of the Receiver you must put some Leaves of Gold; Then put Fire under the Limbeck, until Vapours arise, which will cleave unto the Gold; Augment your Fire till there ascend no more: Then take away your Receiver, and close it *Hermetically*; and make a Lamp Fire under it, and in a short time you shall see presented to you, almost all things which Nature affords; *viz.* Trees, Flowers, Fruits, Fountains, the Sun, Moon, Stars, &c.

To make a Perpetual Motion.

Paracelsus and his Followers have bragged, that by their *Separations* and *Extractions* they can make a *Little World*, which shall have the same perpetual *Motions* with this *Microcosme*, with the representation of all *Meteors*, *Thunder*, *Snow*, *Rain*, the *Courses* of the *Sea* in its *Ebbs* and *Flows*, and the like; and one of them I find in the 118 *Prop.* of the *Esthenary* of *Mathematical Recreations*; which is this, Mix Five Ounces of φ with an equal weight of ψ , grind them together with Ten Ounces of *Sublimate*; dissolve them in a Celler upon some *Marble* for the space of four days, till they become like *Oil-Olive*; Distil this with Fire of Chaff, or Driving Fire, and it will sublime into a dry substance; and so by repeating of these *Dissolvings* and *Distillings*, there will be at length produced divers small *Atoms*, which being put into a *Glas* well Luted, and kept dry, will have a *Perpetual Motion*.

C H A P. VI.

Of a famous Perpetual Motion invented by Cornelius Dreble, and made for K. James I. wherein was represented the constant Revolutions of the Sun and Moon, and that without the help either of Spring or Weight.

M Arcellus Vranckbein speaking of the means whereby it was performed, he calls it *Scintillula animæ Magneticae Mundi, seu Astralis & insensibilis spirittis*: Being that grand secret which those Dictators of Philosophy, *Democritus*, *Pythagoras* and *Plato* did Travel to the Gymnosophists and *Indian Priests*. The Author himself does not reveal the way how it was performed: But one *Thomas Tymme*, (one that did often pry into his works) affirms it to be done thus; By extracting a Fiery Spirit out of the Myneral Matter, joyning the same with his proper Air, which included in the Axle-Tree (of the first moving Wheel) being hollow, carrieth the other Wheels, making a continual Rotation, except issue or vent be given to this hollow Axle-Tree, whereby the imprisoned Spirit may get forth.

But these, and such like miraculous promises, would require as great a Faith to believe them, as a Power to perform them.

C H A P. VII.

Of the making of GOLD.

C Concerning this Matter, I shall only set down (in his own Words) the *Opinion* of the Right Honourable *Francis Lord Verulam*, Viscount *St. Alban*, in his *Natural History*, Century IV. and *Experiments Solitary*, touching the *Making of GOLD*.

The World (saith he there) hath been much abused by the *Opinion* of *Making of Gold*: The *Work* it self I Judge to be possible; But the *Means* (hitherto propounded) to effect it, are, in the *Practice*, full of *Error* and *Imposture*: And in the *Theory*, full of *unsound Imaginations*: For to say that *Nature* hath an *Intention* to make all *Metals Gold*: And that, if she were delivered from *Impediments*, she would perform her own *Work*: And that if the *Crudities*, *Impurities* and *Leoprosities of Metals* were cured, they would become *Gold*: And that a little *Quantity* of the *Medicine*, in the *Work of Projection*, will turn a *Sea of the Baser Metal* into *Gold*, by *Multipling*: All these are but *Dreams*;

Dreams ; and so are many other Grounds of *Alchymy*. And to help the Matter, the *Alchymists* call in likewise many Vanities, out of *Astrology*, *Natural Magick*, Superstitious Interpretations of *Scripture* ; *Auricular Traditions* ; Feigned Testimonies of *Ancient Authors* ; and the like. It is true, on the other side, They have brought to light not a few profitable *Experiments*, and thereby made the World some amends. But we, when we shall come to handle the *Version*, and *Transmutation* of *Bodies* : And the *Experiments* concerning *Metals*, and *Minerals* ; will lay open the true Ways and Passages of *Nature*, which may lead to this *Great Effect*. And we commend the Wit of the *Chineses*, who despair of making *Gold*, but are mad upon making of *Silver* : For certain it is, that it is more difficult to make *Gold* (which is the most Ponderous and Materiate amongst *Metals*) of other *Metals*, less Ponderous, and less Materiate : then (*viâ versâ*) to make *Silver* of *Lead*, or *Quick-silver* ; both which are more ponderous than *Silver* : So that they need rather a further degree of *Fixation*, then any *Condensation*. In the mean time, by occasion of handling the *Axioms* touching *Maturation*, we will direct a *Trial* touching the *Maturing* of *Metals* ; and thereby turning some of them into *Gold* : For we conceive, indeed, that a perfect good *Concoction*, or *Digestion* of *Maturation* of some *Metals*, will produce *Gold*. And here we call to mind, that we knew a *Dutch-man*, that had wrought himself into the belief of a Great Person, by undertaking that he could make *Gold* : Whose Discourse was, That *Gold* might be made, But that the *Alchymists* Over-fired the Work : For (he said) the making of *Gold* did require a very temperate *Heat*, as being in *Nature* a Subterrany work, where little *Heat* cometh ; but yet more to the making of *Gold*, then of any other Metal ; And therefore, that he would do it with a Great *Lamp*, that should carry an Equal and Temperate *Heat* : And that it was the work of many Months. The device of the *Lamp* was Folly ; but the Over-firing now used, and the equal *Heat* to be required, and the making it a work of some good Time, are no ill Discourses.

We resort therefore to our *Axioms* of *Maturation*, in effect touched before : The first is, That there be used a *Temperate Heat*, for they are ever *Temperate Heats* that *Disgest* and *Mature*, wherein we mean *Temperate*, according to the *nature* of the *Subject* ; For that may be *Temperate* to *Fruits* and *Liquors*, which will not at all work upon *Metals*. The second is, That the *Spirit of the Metal* be quickned, and the *Tangible parts* opened : For, without these two Operations, the *Spirit* of the *Metal* wrought upon, will not be able to disgest the parts. The Third is, That the *Spirits* do spread themselves even, and move not subjuorily ; For that will make the Parts Close and Plyant. And this requires a *Heat*, that doth not rise and fall, but continue as *Equal* as may be. The Fourth is, That no part of the *Spirit* be emitted, but detained. For, if there be *emission* of *Spirit*, the Body of the *Metal* will be Hard and Churlish : And this will be performed, partly by the temper of the *Fire*, and partly by the closeness of the *Vessel*. The Fifth is, That there be *Choice made of the likeliest and best prepared Metal, for the Version* : For that will facilitate the work. The Sixth is, That you give *Time enough for the Work* : Not to prolong hopes, (as the *Alchymists* do) but, indeed, to give *Nature* a convenient space to work in : These Principles are most Certain and True. We will now derive a direction of *Trial* out of them,

them, which may (perhaps) by further meditation, be improved.

Let there be a small *Furnace* made, of a *Temperate heat*; let the *heat* be such as may keep the *Metal perpetually Molten*, and no more; for that, above all, importeth to the *Work*. For the *Material*, take *Silver*, which is the *Metal* that in *Nature* Symbolizeth most with *Gold*; Put in also with the *Silver*, a Tenth part of *Quick-Silver*, and a Twelfth part of *Nitre* by *Weight*; both these to *Quicken* and *Open* the *Body* of the *Metal*: And so let the *Work* be continued by the *space of six Months* at least. I wish also that there be, at some times, an *Injection* of some *Oyled substance*; such as they use in the recovering of *Gold*, which by *vexing* with *Separations* hath been made *Churlish*: And this is to lay the parts more *Close* and *Smooth*, which is the main *Work*: For *Gold* (as we see) is the *Closet* (and therefore the *Heaviest*) of *Metals*: And is likewise the most *Flexible* and *Tensible*.

Note, That to think to make *Gold* of *Quick-Silver*, because it is the *heaviest*, is a thing not to be hoped; For *Quick-silver* will not endure the *Manage* of the *Fire*. Next to *Silver*, I think *Copper* were fittest to be the *Metal*.

Concerning the Nature of GOLD.

Gold hath these *Natures*: *Greatness of Weight*; *Closeness of Parts*; *Fixation*; *Pliantness*, or *Softness*; *Immunity from Rust*; *Colour or Tincture of Yellow*. Therefore, the sure way (though most about) to make *Gold*, is to know the *Causes* of the several *Natures* before rehearsed, and the *Axiomes* concerning the same: For if a *Man* can make a *Metal* that hath all these *Properties*, Let *Men* dispute, whether it be *Gold* or no?

C H A P. VIII.

Of Incombustible Flax, or a Substance which will not consume by Fire.

HAVING in the foregoing Section spoken of *Subterranean Lamps*, I will here say something concerning a *Substance* which will not consume by *Fire*: There was anciently a kind of *Flax* which the *Grecians* called *Asbestinum*, the *Latines* *Linum vivum*: Hereof were made whole *Pieces* of *Linnen Cloath*, and *Garments*, which were not only not consumed by any *Fire*, but being cast into the same, the *Soil* and *Filthiness* being consum'd and burn'd away, taken out again, it became more white than any *Water* could wash it. The *Bodies* of *Emperors* and *Kings* were buried in *Sheets* of this *Linnen*, lest the *Ashes* of their *Bodies* burned, should mingle with the *Ashes* of the wood wherewith the *Body* was burned. This *Flax*, saith *Pliny*, is hard to be found, and as difficult to be *Woven*, by reason of the shortness thereof; and being found, in price it equalled the most excellent *Pearls*. *Nero* is reported to have had a *Linnen Garment* of the same; but at this day it is not any where to be found. Yet I remember, (saith my Author *H. P.*) I had given

given me by an *Arabian* in the year 1618. a pretty quantity of a Stuff like Flax, which he had me put into the Fire, but it consumed not: Whither it were of this Flax or no, or that Flax of *Cyprus*, which *Pondacatarre*, a Knight of *Cyprus*, who wrote an History of *Cyprus*, Anno 1566. brought to *Venice*, and the Fire could not consume it, I know not. Now this Flax of *Cyprus* proceedeth from no Plant, as our Flax, but from the Stone *Amiantus*, which being found in *Cyprus*, and broken with an Hammer (the Earthy Dross being purged from it) there remains fine Hairy Threads like unto Flax, which are Woven into Cloath. This Flax was seen in the House of the said *Pondacatarre* by many Men of Worth and Credit, as *Porcatio* witnesseth, *Tab. 2. Euneranium*. Wherefore Linnen being made of the Flax or Threads of this Stone, must needs be incumbustible.—*Constantine* the Emperor ordained that it should ever burn in *Lamps* in his Chappel, at *Rome*: This Reports *Damascus* in the Life of Pope *Sylvester*. Moreover *Ludovicus Vives*, in his Commentaries upon *St. Augustins de Civitate Dei*, *Lib. 21. c. 6.* saith, That he saw *Lamps* at *Paris* whose Lights never consumed. Also at *Louvain*, a fowl Napkin taken from the Table at a Feast, and thrown into the Fire, and being quite Red as a Coal, was taken out again, cooled, and restored to the owner, more White than if it had been washed with Water and Soap: And the like my self have heard, That a Cook dressing of a Dinner at a Nobleman's House, whose Lord was to Dine there; The Noble-Man seeing this strange Cook with' a Greasie Apron and fowl Sleeves, said to him, That if the Persons that were to Dine with him should see his Beastly Accoutrements, they would loath to eat the Meat that he should dress; whereupon the Cook pulls off his Apron and Sleeves, and throws them into the Fire, which in a very short time were made Red-hot, and being taken out and cooled, became White as Snow. And now to conclude this matter, I remember that about the year 1648, or 9, I was in company at a Tavern with some Gentlemen, and one of the Company took out of his Pocket a piece of a kind of a Stone, about the bigness it was of a Wall-nut, the outside whereof was of a dirty Earthy Colour; but the inside of a bright Ash-colour, not much unlike Steel when a Bar of it is new broken; and for weight it did ponderate equal with Steel: Off of the inside of this piece of Stone, several of the Company (my self for one) did with our Knives scrape off a kind of Woolley, soft Flax, and putting it to the Candle, there burning, it became immediately Red-hot, but no way consumed or diminished, but came out of the Fire White, whereas it was in the Stone of a bright Ash-colour, as I said before.

C H A P. IX.

Some Relations concerning Subterraneous Lamps.

1. **S**T. *Austine* mentions one of them in a Temple dedicated to *Venus*, which was always exposed to the open weather, and could never be consumed or extinguished.

2. *Puncirollus* mentions a Lamp found in his time, in the Sepulchre of *Tullia*, *Cicero's* Daughter, which had continued there for above 1550 years; but was presently extinguished upon the admission of new Air.

3. It is related of *Cedrenus*, that in *Justinian's* time there was a Lamp found in a Wall at *Edeffa*, which had remained so for above 500 years, there being a *Crucifix* placed by it; from whence it should seem, that these *Lamps* were of use amongst some Christians.

4. *Olybius* his Lamp, which had continued burning for above 1500 years; the Story is this: A Rustick digging the Ground in *Patavia* in *Italy*, he discovered a very Ancient Monument, and in it an *Urn*, or *Earthen Pot*, in which there was another *Urn*, and in this lesser, a *Lamp* clearly burning; on each side of it there were two other *Vessels*, each of them full of a pure *Liquor*, the one of *Gold*, the other of *Silver*: And the most Learned of that Age coming to the Monument, affirmed the same to be that Perpetual Fire invented by the wonderful industry of the Ancient Philosophers, which would indure so many years. In which Opinion they were confirmed by Verses written in either *Urn*, which seemed to be of great Antiquity by their vein:

These were in the Bigger Urn:

Platoni Sacrum munus, ne attingite fores;
Ignotum est vobis, hoc quod in Orbe latet.
Namq; elementa gravi, clausit digesta labore,
Vase sub hoc modico, Maximus Olibius;
Adsit facundo, custos tibi copia cornu,
Ne pretium tanti, depereat laticis.

These were in the Lesser Urn.

— *Abite hinc pessimi fures,*
Vos, qui vultis vestris cum oculis emissis;
Abite hinc, vestro cum Mercurio petasato, caduce
Atq; Maximus, maximo domum Platoni, hoc
Sacrum facit:

One *Matarants* had the possession of these after they were taken up.

5. *Baptista Porta* tells us of another Lamp burning in an old Marble Sepulchre, belonging to some of the Ancient Romans, inclosed in a Glass Vial, found in his time, about the year 1550. in the Isle of *Nefis*, which had been buried there before our Saviour's coming.

6. In the Tomb of *Pallos* the Arcadian, who was slain by *Turnus* in the Trojan-Wars, there was found another Burning Lamp, in the year of our Lord 1401, whence it should seem it had continued above 2600 years, and being taken out, it did remain burning, notwithstanding either Wind or Water, with which some did strive to quench it; neither could it be extinguished till they had spilt that Liquor which was in it.

7. *Ludovicus Vives*, tells us of another Lamp, that did continue burning for 1500 years, which was found a little before his time.

8. There is a relation of a certain Man, who digging somewhat deep in the Ground, did meet with something like a Door, having a Wall on each hand of it; from which having cleared the Earth, he forced open the Door; upon this there was discovered a fair Vault, and towards the farther side of it, the Statue of a Man in Armor, sitting by a Table, leaning upon his Left Arm, and holding a Scepter in his Right-hand, with a Lamp burning before him: The Floor of his Vault being so contrived, that upon the first step into it, the Statue would erect it self from his Leaning Posture; upon the second step it did lift up the Scepter to strike: And before a Man could approach near enough to take hold of the Lamp, the Statue did strike, and beat it to Pieces.

9. *Cambden* relates in his description of *Tork-shire*, speaking of the Tomb of *Constantius Chlorus* broken up in these later years, mentions such a Lamp to be found within it.

10. In most of the ancient Monuments, there is some kind of Lamp, tho' of the ordinary sort: But those Persons that were of greatest Note and Wisdom, did procure such as should last without supply, for so many Ages together. And,

11. *Pancirollus* tells us, that it was usual for the Nobles among the Romans, to take special care, in their Last Wills, that they might have a Lamp in their Monuments.

12. *St. Augustine* tells us, that in the Temple of *Venus* was a Lamp that never went out, which he supposed to have been done, either by Art Magical, or by industry of some Man, who had put *Lapidem Asbestum*, or the unquenchable Burning-Stone within the same Lamp.

Concerning these Lamps found burning in Graves, I wonder, (1.) How by the help of Art (for Chymists say this Oyl is made of Gold,) Gold may be resolved into a Fatty substance! (2.) How the Flame should endure so many years! (3.) How within the Ground, all Air being excluded.

RECREATIONS

Automatical.

CHAP. I.

*Of the Nature and Making of Watches, Clocks,
and other Movements.*

THE Precepts following are such as were by Sir *Jonas Moor*,
Extracted out of a Manuscript of Mr. *William Oughtreds*, by
him made for his Sons private Use, he being of that Profession.
The *Great Wheel* whereon the *Fusee* or *String* with *Weights* are fixed,
divides the Nature of the Work in any *Movement*: That is to say, All
the *Wheels* and *Pinions* from that *Great Wheel* to the *Ballance* or *Fly*,
only prepare the *Motion*, but the other way effect it: In pursuance
whereof, two things are to be noted.

1. The *Fusee*, and how many *Turns* it hath.
2. The *Number* and *Names* of the *Wheels*, *Teeth* and *Pinions*.

Example: In a *Watch* of *Four Wheels*: Suppose the *Numbers* follow-
ing to be the *Teeth*:

First, The *Great Wheel* [Number 55. *Teeth*] Turning the *Pinion*
[Number 5.] fixed to the *second Wheel*.

Secondly, The *Second Wheel* [Number 45.] turning the *Pinion*
[Number 5.] fixt to the *Contrat Wheel*.

Thirdly, The *Contrat Wheel* [Number 40.] turning the *Pinion*
[Number 5.] fixt to the *Crown Wheel*.

Fourthly, The *Crown Wheel* [Number 17.] having *Odd Teeth*,
working upon the *Pallots* of the *Ballance* [Number 2.]

Thus for *Watches* of *four Wheels*: But for *Watches* with *five Wheels*,
there will be a *Third Wheel* before the *Contrat Wheel*.

Fifthly, The *Pinion of Report*, fix'd to the *Arbor* of the *Great
Wheel* [Number 4.] which lies hid betwixt the *Plates* in *Watches*, and
turns the *Hour-Wheel* [Number 36.] which carries the *Hand* about up-
on the *Face*; divided into 12 or 24 *Hours*.

For

A U T O M A T I C A L E

For brevities sake, let

- M Stand for *Movement*, whether *Watch* or *Clock*.
- F The *Fuse*.
- A The *Great Wheel*.
- a The *Pinion* of *Report* on the *Arbor*.
- E The *Second Wheel*.
- e The *Pinion* on its *Axis*.
- I The *Contrat Wheel*.
- i The *Pinion* on its *Axis*.
- O The *Crown-Wheel*, carrying
- o Its *Pinion* on its *Axis*.
- B The *Dial-Wheel* carrying the *Hand* in 12 hours.
- T *Time*.
- t *Turns*.
- N *Notches*, or *Beats* of the *Ballance*.
- Con. *Continuance*, and *Length* in *Time* of the *Watches* going.

The Work stands both in *Letters* and *Figures*, as in the *Example*.

$$\begin{array}{r}
 a) B(d\ 4) 36\ (9) \\
 \hline
 e) A(f\ 5) 55\ (11) \\
 i) E(g\ 5) 45\ (9) \\
 o) I(k\ 5) 40\ (8) \\
 O \quad 17\ \text{Crown Wheel} \\
 \quad 2\ \text{Pallats.}
 \end{array}$$

Where every Wheel is Divided by the *Pinion* it moves from, *A* the Great Wheel, to *O* the *Crown-Wheel*, viz. 55, by 5 equal to 11, equal to *f* 5.— 45 69 5 equal to 8, equal to *k*— But *B* divided by *a* gives 9, that is, *B* by *a*, equal to *d*.

R U L E I.

Where *f* 11, *g* 9, *k* 8, *o* 17, and 2 *Pallats* Multiplied into each other successively, produce 26928 equal to *N*, the *Notches* or *Beats* made in one Turn of the *Great Wheel*: And 26928 Multiplied by 9, is equal to 242352, the *Beats* that are made in one turn of the *Hand*, whether 12 or 24— Lastly, Divide 242352 by 12, it gives 20196, the *Beats* in one *Hour*; and 20196 Divided by 60, gives 336.6, the *Beats* in one *Minute*. All this is plain enough, and is the foundation of the whole Work, and by it may be easily found how many *Turns* any *Wheel* or *Pinion* makes for one *Turn* of the *Fuse* or *Hour-wheel*.

R U L E II.

As the <i>Beats</i> for one <i>Turn</i> of the <i>Great Wheel</i> , or <i>Fuse</i> .	26928
Is to the <i>Beats</i> gone in one <i>Hour</i>	20196
So is the <i>Continuance</i> of the <i>Time</i> of the <i>Watches</i> going	16 ho.
To the <i>Quotient</i> of the <i>Hour-Wheel</i> divided by <i>a</i> , the <i>Pinion</i> of <i>Report</i> .	} 9
	These

R E C R E A T I O N S

These Proportions holding, then any Three given (not of the same kind) you may find a Fourth. As by *Example*.

To know the Continuance of the Watches going, that hath 12 Turns in the Fusie, and 26928 Beats in one Turn, and 20196 Beats in an Hour. Say,

As the number of Beats of the Ballance in an Hour

Is to the number of Turns in the Fusie,

So is 12 Turns of the Fusie

To the Continuance of Time of the Watches going.

For 20196 : 26928 :: 12 : 16.

But if it be demanded by the Beats, and the Time of the Watches going, to know the Turns of the Fusie: Then it will be,

As 26928 : 20196 : 16 : 12.

Or, if it be demanded what Quotient shall be laid upon the Pinion of Report. Then say,

As 16 : 12 :: 12 : 9

Or, 26928 : 20196

Note, That the fewer Beats are taken, the longer shall be the Continuance of the Watches going at an Equal Time.

R U L E III.

Concerning P E N D U L U M S.

THE Spring in a Watch drawing harder at the first, than at the last: And likewise in Clocks with Weights and Strings, there is added the weight of the String gotten every moment to the Clock Weight; and for that no Motion can be Made by hand so fit, but there will come some unequalness, as you may hear by the Beats either of Watch or Clock. To justen and regulate these inequalities, Monsieur Hugen's invented the way of applying Pendulums to either, for which his name will be ever in venerable esteem.

Pendulums whose Vibrations are of the same Degree and Minute, are Equal, or if they rise not above a Degree; And the Squares of their Vibrations are in proportion to their Lengths: For a Standard or Rule, the aforesaid Monsieur Hugen's gives the length of a Pendulum that shall Swing Seconds, to be 881 to the Parisian Feet, 864. The English Feet to Paris Feet, by a Table of Sir Jonas Moors are, As 1000 to 1068, Therefore, As 864 : 881 :: 1.068 : 1.089 : And 1.089 Multiplied by 3, is equal to 3.267, i. e. equal to Three Feet, Three Inches, and two Tenths of an Inch.

The late Honourable Lord Bruncker, and Mr. Hook, found the Length to be 39 Inches, and .325 Parts, which a little exceedeth the other, and it may be was justned by Monsieur Hugen's Rule for the Center of Oscillation: For Montons Pendulum that shall Vibrate 132 times in a Minute, it will be found likewise 8.1 Inches, agreeing to 39.2 Inches, English: Therefore, for certain, 39.2 Inches may be called, *The Universal Measure*; and relyed upon to be the neer Length of a Pendulum that shall Swing Seconds every Vibration: With this Caution and Rule.

As

A U T O M A T I C A L.

As the length of the *String* from the point of the *Suspension* to the *Centre* of a *Round-Ball*,

Is to the *Radius* ;

So is *Radius*

To a *Fourth Number*.

Let $\frac{3}{5}$ two *Fifths* of that *fourth Number*, be added to the former *Length*, for the *Length* of the *Pendulum*. Having this *Standard*.

The next R U L E is this.

THAT the *Lengths* of two *Pendulums*, are in *Proportion* to the *Squares* of their several *Vibrations* ; which will be equal to the *Beats* of the *Ballance* ; therefore the *Beats* that shall be proposed in a *Minute* being given, to be 50 ; and it be demanded to give the *Length* of a *Pendulum*, The *Analogy* is,

As the *Square* of 50, viz. 2500

Is to the *Square* of 60, viz. 3600,

So is 39.2

To 56.4, the *Length* required: For,

As 2500 : 3600 :: 39.2 : 56.4

And if the *Length* be given, to find the *Swings* or *Beats* in a *Minute*, The *Analogy* is,

As the *Altitude* given,

To the *Altitude* known,

So the *square* of the *Vibrations* known,

To the *square* of the *Vibrations* required,

• The *square Root* whereof is the *Answer*.

And because the two middle *Terms* stand in all such *Questions*, and will be always 141120; therefore divide 141120, by the *square* of the *Swings* in a *minute*, it gives the *length* sought: or, by the *length*, it gives the *square* of the *Swings*.

And thus a *Swing* may be hang'd by any *Clock*, upon a *Pin*, so that it may freely *Vibrate* to *Regulate* the same *Clock*.

$$\begin{array}{r}
 48) \text{---} 4 \quad (12 \\
 \hline
 56 \text{---} 7 \quad (8 \\
 54 \quad 6 \quad (9 \\
 \hline
 21
 \end{array}$$

The *Numbers* of the *Great Wheel* 56.

Its *Pinion* 4, turning the *Hour-wheel* 43.

The *great Wheel* turning a *Pinion* of 7, fixt to

The *Crown Wheel* 54, turning a *Pinion* of 6, fixt to

The *Ballance-wheel* 21.

The *Quotients* 8, 9, 21, and 2 *Multiplied* into each other, produce 3024, Equal to the *Beats* in an hour: Because the *great wheel* turns once in an hour.

Other-

R E C R E A T I O N S

Otherwise 12, 8, 9, 21, 2, Multiplied into each other, produce 36288.— 12) 36288 (3024, and 60) 3024 (50.4 Beats in a Minute : And (as was shewed before) the Length of the Pendulum will be 55.5 Inches.

Fix a Weight upon a Wyre, running into a Rod, that shall have four Feet 7.5 Inches below the Pin whereon it plays ; and about a Foot (or above) a Wyre beaten flat, with several holes to fit to the Top of this Rod ; and to a Pin placed upon the Balance towards the back-side, will regulate the Motion exceeding well.

For the Regulating the inequality of a Swing, when it may rise sometimes high, sometimes lower : There are two ways, either by making the Line play betwixt two Checks of a Cycloid, as Monsieur Hugen's hath directed, which may easily be effected to any Length of the Pendulum : Or else, by not suffering the Pendulum to Vibrate above an Inch from its settlement.

Monsieur Hugen's in his Book of Pendulum Clocks, proposeth a Watch about a Mans height to go 30 Hours, and to have these Numbers.

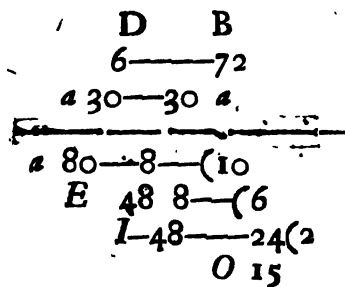

The Great Wheel 80, &c. which turns about in an Hour, and shews Minutes ; therefore for an Hour, Multiply the Quotients 10, 6, 2, 15, 2, and they will produce 3600, the Seconds in an Hour (60 in 60) is equal to 3600, or Beats. Now the Third Wheel I turn about in one Minute, for 10 in 6 is equal to 60, and carries a Plate divided into 60 Seconds, and shews the Seconds : And upon the Arbor of the Great Wheel, is fixed a Wheel, *a*, turning another Wheel *e*, both of 30 Teeth ; and both turning about in an Hour ; the latter has on it a Pinion *b* of 6 Teeth, turning *B* 72 in 12 Hours. This Watch hath a Pully tyed to its Weight, by which you may pull it up, and not stop the Watch. The Pendulum plays between two Checks, part of a Cycloid.

The next Question (supposing there be a Screw below, or above the Pendulum, to lift it up, or let it down upon a Square Brass Rule, divided into Inches and Tenth Parts) to know how many Minutes and Seconds every Tenth Part of an Inch will make the Watch go faster or slower in a Day.

I take the Pendulum which swings Seconds, whose length is 39.2, And then by the Logarithms I make the following Table.

A U T O M A T I C A L.

I.	II.	III.	IV.	V.
38.7	1.587711	1.790988	60.39	9.21
38.6	1.588832	1.780378	60.31	7.26
38.9	1.589949	1.779819	60.23	5.31
39.0	1.591065	1.779261	60.15	3.36
39.1	1.592177	1.778705	60. 8	1.55
39.2	1.593286	1.778151	60.	1.11
39.3	1.594393	1.777597	59.92	1.55
39.4	1.595496	1.777046	59.85	3.36
39.5	1.596597	1.776495	59.77	5.31
39.6	1.597695	1.775996	59.70	7.26
39.7	1.598790	1.775399	59.62	9.21

The first Column in the Table, has in the Middle the *Length* of the *Pendulum* 39.2 Inches : *Upwards* it diminisheth one Tenth, and *downwards* increaseth one Tenth.

The Second Column, are the *Logarithms* of the First.

The Third Column, are half of the *Logarithms* of the difference of the II. taken out of the *Logarithm* 5.149588, which is, of the standing Number 141120 aforesaid.

The Fourth Column are the Numbers answering to the *Logarithms* in the III.

The Fifth Column are the *Minutes* and *Seconds* that those *Augmentations* or *Diminishings* will cause in a Day; and are obtained by Multiplying 24 in 60, which makes 1920 equal to the *Minutes* in one Day, by the *Decimals* above or under 60". which work may be easily done; for any length of a *Pendulum*.

R U L E IV.

Of finding out fit Numbers for the Wheels and Pinions.

1. **A**NY two Fractions whose Terms are proportional perform the same Motion;

$$\text{As } \frac{9}{1} \frac{36}{4} \frac{45}{5} \frac{63}{7}$$

The upper for the Wheel,

The lower for the Pinion.

2. If it be, As one Wheel, to one Pinion,

So is the Product of many Wheels,

To the Product of many Pinions: And both will perform the same Motion.

Example.

$$\text{So } \frac{1440}{28} \text{ is equal to } \frac{36 \cdot 8 \cdot 5}{28 \cdot 1 \cdot 1}$$

$$\text{And } \frac{36 \cdot 8 \cdot 50}{4 \cdot 7 \cdot 10} \text{ is equal to } \frac{14400}{280} \text{ equal to } \frac{1440}{28}$$

And it matters not in what Order the Wheels and Pinions are set, or which Pinion stands under every Wheel.

3. These Factors 36 in 8, *i. e.* 288, may thus be varied, *viz.* Divide them by such Numbers as will Measure them, and Multiply the Quotients by the Alternate Divisors: The Product of these two last Numbers shall be two to the Product of the Factors given. For 36 in 8 is 288: Equal to 9 in 32, equal also to 288.

4. If fit Numbers cannot be had by any of the Three former ways, you must seek some *Ratio*, as near as possible, in this manner.

As one of the two Numbers

Is to the other;

So is 360,

To a Fourth Number:

Divide this Fourth Number, and also 360, by 4, 5, 6, 7, 8, 9, 10, 12, 15, or which of them bringeth the *Quotient* nearest to an *Intiger*—As if the two Numbers be 247 and 170, (which are too great to be cut into Wheels) and yet cannot be reduced into less, because they have no greater Common Measure than Unity: Say therefore,

$$\begin{array}{l} 170 : 147 :: 360 : 3114 \\ 147 : 170 :: 360 : 4164 \end{array} \quad \begin{array}{l} 311 \overline{) 52} \\ 360 \overline{) 60} \end{array}$$

$$\begin{array}{l} 311 \overline{) 39} \\ 360 \overline{) 45} \end{array} \quad \begin{array}{l} 360 \overline{) 45} \\ 416 \overline{) 52} \end{array}$$

Wherefore, For the two Numbers 147, and 170, you may take 52 and 60—39 and 45—45 and 52.

R U L E V.

The *Diameter*, or *Circumference* of any *Wheel* being given, in Inches and hundred parts of an Inch, and the Number of Teeth it is divided into; to give the *Diameter*, or *Circumference* of a *Lesser Wheel* or *Pinion*, with a number of Teeth given, shall exactly agree with the Teeth of the *Greater Wheel*.

Example. The *Great Wheel* hath One Inch *Diameter*, and 50 Teeth: The *Lesser Wheel* or *Pinion* 10 Teeth, say,

$$\text{As } 7 : 22 :: 1 : 3.14$$

And Again

$$\text{As } 50 : 3.14 :: 10 : 63 \text{ Ferè}$$

For the *Circumference* of the *Pinion*, whose *Diameter* will be .2 Tenths of an Inch.

R U L E

R U L E VI.

TO give Numbers to a Watch that shall have a swift Train, about 20000 Beats in an Hour, that may have Turns about the Fuse, and go 16 Hours; and the Number of the Crown Wheel 17.

Say (by R U L E II.)

As 12 : is to 16 :: So is 20000 : to 26666, the Beats for one turn of the Fuse : And because (by R U L E I.) 26666 is equal to all the Quotients Multiplied together into 17, and into 2, that Number being halv'd is 13333, and that again divided by 17, gives for the Quotient 784, which being broken into Three Numbers, which Multiplied together, will be 784, or near to it; let them be 11, 9 and 8, which Multiplied into each other, are 792 : Then 792 in 17 in 2, are equal to 26928, And then say,

As 16 : 12 :: 26928 : 20196, the Beats in one Hour. Also,

As 16 : 12 :: 12 : 9.

Lastly, By these three Quotients assured 11, 9 and 8, find out the Three Wheels and Pinions, by taking the Pinions as you desire, as is done in the Margine. You may try several Experiments, to make the Watch go Longer, by altering the Beats and Pinions of Report.

$$\begin{array}{r} 36 \\ \frac{9}{1} \times \frac{36}{2} \\ 36 \\ 4) 36 (9 \\ \hline 5) 55 (11 \\ 5) 45 (9 \\ 5) 40 (8 \\ \hline 17 \\ 2 \end{array}$$

EXAMPLE, Of a Clock or Watch proposed to go a Week (or Eight Days) with this Order : That the Ballance Wheel, or that which moves the Pendulum, may go about in a Minute, with an Index to shew Seconds : That the Great Wheel may go about in 12 Hours : And that the Wheel next it may go about in One Hour to shew Minutes.

First, Find how many Seconds there are in 12 Hours, by Multiplying 12 in 60, equal to 43200, and these are the Beats that shall be in one turn of the Great Wheel. These are double, because there are two Swings to one Tooth of the Ballance Wheel; The half of 43200 is 21600; Now the Ballance Wheel must needs be 30; Divide 21600 by 30, the Quotient will be 720, which is to be broke into Three Quotients, whereof the first must needs be 12 for the Teeth of the Great Wheel; Divide 720 by it, the Quotient is 60 for the two Quotients remaining, which may be either 10 and 6, or 5 and 12, or 8 and 7½, which last let stand, and then the Work will stand as in the Margine, thus : And the Pinions to be taken as you please, to be all 8, the Wheels must be 96, 64, and 60; so then the great Wheel will go about in 12 hours; the second Wheel in an Hour, and the Ballance Wheel in a Minute, as was desired.

$$\begin{array}{r} 8) 96 (12 \\ 8) 64 (8 \\ 8) 60 (7\frac{1}{2} \\ \hline 30 \\ \hline 10.140 \\ 8.128 \\ 8.120 \\ \hline 72. \end{array}$$

R U L E VII.

Of giving particular *Motion* to any *Movement*.

THe Number of a *Motion* is the proportion that it bears to one *Turn* of the *Hour Wheel*, or the *Pinion* of *Report*, from whither soever it be taken, which Proportion being broken into *Two* or *Three Quotients*, will shew the *Wheels* and *Pinions*, as if you took it for the *Beats* of the *Ballance*.

A N O T E Concerning *Time*. That which is ordinarily called *The Hour of the Day*: You are to consider this in the length of *Days*, which are twofold, distinguished only by the *Revolutions* of the *Earth* or *Sun*. The First is the *Syderial Day*, where any fixt point or points of the *Earth* in the same *Meridian* or *Azimuth*, returns from any *Star* to the same again. The Second is the *Solar Day*, where the same *Meridian* of the *Earth* returns from the *Sun* to the same again: Neither of these two are the true *Equinoctial day*: Indeed, the *Syderial* is insensibly the same, if it be but for some small space of *Time*, the Difference being only some *Fourths* and *Fifths* of a *degree* slower in a *Day*; but the *Solar* is notably *Longer* than the other, *viz.* By 3 Minutes, 56 Seconds, 53 Thirds, 19 Fourths of *Time* in a *Day*; and from hence the Length of an *Hour* is generally accounted. Therefore to fit the *Pendulum* of a *Watch* or *Clock* to this *Solar Day* and *Hour*:

I. By the *Revolution* of a *Fixed Star* to the same point again, after one or more *Revolutions*, (which you must curiously *Observe* by fixing your *Eye* to a *Point* :) If the *Motion* for one *Revolution* want 3 Minutes 56 Seconds of 24 hours; or for *Two* 7 Minutes 43 Seconds; for *Three* 40 Minutes 39 Seconds, &c. Then doth your *Watch* or *Clock* go true to the *Equall* or *Middle Motion* of the *Sun*; if otherwise, the *Pendulum* must be altered to make it go so.

II. By a *Sun Dial*, which though it be made never so exact, and your *Motion* so too, yet there will be a considerable difference after some *Dayes*, nay, even in one *Day*: All which falls out by reason of the *Inequality* of *Natural Days*. And this inequality is now at last settled and demonstrated by Mr. *William Flamsted*: A Table of his for this Equation for every *Day* in the year, I have here inserted: And although it be not the very same every year, yet this (being for the year 1693) will sufficiently serve for any other.

Of the following **T A B L E** of Equation of *Time* and its Use; How hereby to Regulate a true made *Pendulum Clock* or *Watch*, shewing how much it ought to differ from the same *Sun Dial*.

THe following *Table* shews the *Equation of Time* in *Minutes* and *Seconds* (as the Letters *M* and *S*, at the head of each *Column* denotes) for every day of the year, having these Words in the middle of each *Column*, *Watch too Fast*, or *Watch too Slow*: And is of excellent Use, as appears by this which follows out of my loving friend Mr. *George Parker* in his *English Mercury* for the Year 1693.

Not-

Notwithstanding, all persons generally conclude, that the Sun by his Motion shews, the *apparent time* of the *Day*, which is true, and that a *South Sun* always makes *Noon*, or 12 a *Clock*; yet this *Southing* of the Sun, or the space of time from one *Noon* to the Next, is not equal, but longer or shorter, according to the *Sun's* position in his *Elipsis*; so that it is impossible for any *Clock, Watch* or *Movement* whatsoever, to keep *Time* therewith. For this Reason, many persons that are furnished with excellent *Movements* many times blame the Maker of them, when the *Errors* lie where they are not capable of discerning: For if a *Clock* truly *Rectified*, be set by the *Sun*, and kept going a Year, and at the Year's end, agree exactly again with the *Sun*; yet in the interim, it would be found, at several times, to deviate considerably; and be sometimes too *Fast*, and at other times too *Slow*. The Reason of this *Difference* is: The *Clock* measures *Time* equally, but the *Sun* *unequally*; the Quantity of this *Difference* is, as before express: As thus.

Admit on the first of *February* I would set a *Clock* to shew the *equal time* of the *Day*, I look in the following *Table* against *February* the *First*, and there I find 14 Minutes, 48 Seconds, with the Words, *Watch too Fast*, which informs me, that I must set my *Clock* so much faster than the *Time* given by a *Sun-Dial*, and then, being kept going, it will by the First of *March* be but 10 Minutes *too Fast*; and on *April* the Third, the *Clock* and *Sun* will agree together exactly: Afterwards, the *Clock* will begin to be *Slower*, than the *Sun*, as you may see by the *Table*.

RECREATIONS

A Table of Regulation of Time, for the Regulating of Pendulum Clocks or Watches.

	January		Febr.		March		April		May		June		July		August		Sept.		October		Novem.		Decem.	
	M	S	M	S	M	S	M	S	M	S	M	S	M	S	M	S	M	S	M	S	M	S	M	S
1	9	4	14	48	10	4	0	W45	10	10	1	W2	4	45	4	28	3	53	13	16	15	21	5	35
2	9	26	14	46	9	47	0	W20	9	11	1	W50	4	53	4	18	4	14	13	15	15	13	5	6
3	9	48	14	44	9	30	0	100 F. 12	12	12	0	100 Slow	5	7	4	8	4	14	13	13	14	15	4	5
4	10	10	14	41	9	13	0	*18	13	13	0	100 Slow	5	7	3	57	4	14	13	13	14	15	4	5
5	10	31	14	37	8	55	0		12	12	0		5	13	3	46	5	15	14	11	14	41	3	40
6	10	50	14	32	8	37	0	W33	11	11	0	*	5	18	3	37	5	16	14	23	14	29	3	10
7	11	9	14	27	8	19	0	W48	10	8	0	13	5	24	3	21	5	17	14	34	14	17	2	40
8	11	27	14	21	8	1	0	2	8	6	0	15	5	29	3	8	6	17	14	44	14	17	2	40
9	11	45	14	15	7	43	0	16	6	6	0	39	5	33	2	55	6	14	14	54	14	17	2	40
10	12	2	14	14	7	25	0	28	3	3	0	52	5	36	2	46	6	15	15	4	13	13	1	11
11	12	18	13	59	7	7	0	28	4	4	0		5	39	2	46	6	15	15	4	13	13	1	11
12	12	34	13	50	7	0	Slow.	41	0	50	1	17	5	42	2	26	7	19	15	13	13	17	0	41
13	12	47	13	41	6	47	0	6	41	41	1	30	5	44	2	26	7	19	15	13	13	17	0	41
14	13	2	13	31	6	28	0	16	46	46	1	43	5	45	2	26	8	20	15	15	14	17	0	41
15	13	15	13	21	5	10	0	27	40	40	1	56	5	46	1	26	8	20	15	15	14	17	0	41
16	13	27	13	10	5	32	0	38	34	28	1	8	5	46	1	26	8	20	15	15	14	17	0	41
17	13	38	13	59	5	14	0	48	21	21	1	20	5	45	1	26	8	20	15	15	14	17	0	41
18	13	48	12	47	4	55	0	55	13	13	1	32	5	44	1	26	8	20	15	15	14	17	0	41
19	13	58	12	35	4	36	0	6	5	5	1	44	5	42	1	26	8	20	15	15	14	17	0	41
20	14	7	12	22	4	17	0	14	3	3	2	56	5	40	0	26	8	20	15	15	14	17	0	41
21	14	15	12	8	3	58	0	22	5	5	2	51	5	40	0	26	8	20	15	15	14	17	0	41
22	14	22	11	54	3	40	0	30	48	48	3	19	5	38	0	26	8	20	15	15	14	17	0	41
23	14	48	11	49	3	22	0	37	39	39	3	30	5	34	0	26	8	20	15	15	14	17	0	41
24	14	34	11	24	3	3	0	43	20	20	3	41	5	30	0	26	8	20	15	15	14	17	0	41
25	14	38	11	9	2	45	0	39	19	19	3	51	5	26	1	26	8	20	15	15	14	17	0	41
26	14	42	10	51	2	26	0	53	9	9	4	51	5	20	1	26	8	20	15	15	14	17	0	41
27	14	45	10	38	2	9	0	57	59	48	4	11	5	14	1	26	8	20	15	15	14	17	0	41
28	14	47	10	21	2	9	0	1	48	4	4	20	5	8	1	26	8	20	15	15	14	17	0	41
29	14	48	10		1	51	0	4	37	4	4	29	5	2	1	26	8	20	15	15	14	17	0	41
30	14	49	10		1	34	0	7	37	4	4	37	4	4	1	26	8	20	15	15	14	17	0	41
31	14	49	10		1	17	0	7	37	4	4	37	4	4	1	26	8	20	15	15	14	17	0	41

This

Thus by knowing the *Equal Time*, you may at any time (by help of this *Table*) know the *True* or *Apparent Time*: For, Look against the *Day* of any *Month*, and find the *Æquation*, which if it be *Watch too fast*; then subtract that *Days Æquation* from the *time* given by the *Clock*, and it will be the *Apparent Time*: And if it be *Watch too slow*, then, contrarily, Add the *Æquation* to the *Time* signified by the *Clock*, and you have your desire.

But in the right managing of a *Clock* or *Watch*, it ought, always, to be examined by the same *Sun-Dial* it was *set by*, and at, or near, the *Hour* too, for there is often difference in *Sun-Dials*: And withal, not to *Set* the *Clock* by the *Sun* early in the *Morning*, or late in the *Afternoon*; for then the shadow on the *Dial* is not the true *Time* of the *Day*, in regard the *Sun* hath then considerable *Refraction*, which makes the *Sun* appear higher in *Altitude* than really he is, and the nearer the *Horizon* the *Greater*; So that the *Time* given by the *Sun* is *later* in the *Morning* than truth, and the contrary in the *Afternoon*. Therefore, To observe the true *Time* of the *Day*, let it be always near *Noon*, if it be a *South*, or an *Horizontal Dial* that you make use of: But if it be a *Quadrant* or other *Instrumental Dial*, which give the *Hour* by dependance on the *Sun's Altitude*, it ought to be done with great nicety, and never after *Ten* in the *Forenoon*, nor before *Two* in the *Afternoon*; in regard the *Sun* between the *Hours* of 10 and 2, varies not much in *Altitude*.

RECREATIONS

Historical.

*Of the Measures, and Proportions of the Members
of Man's Body.*

Prooeme.

MAN (saith the Philosopher) is the *Measure* of all things :
First, Because he is the most *perfect* Body.
Secondly, For that (in effect) our usual *Measures*, have taken their *denominations* from *Humane Bodies*, As the *Foot*, the *Inch*, the *Cubit*, the *Pace*, &c.

Thirdly, Because the *Symetry*, and *Concordancy* of the *Parts* of *Man's Body* is so admirable; That all *Magnificent Buildings*, as of *Temples*, *Columns*, &c. are in some *Measure*, *Fashioned* and *Composed* after *Man's Proportion*.

Fourthly, For that *Architects* do resemble the several *Members* of a *Corinthean* and other *Columns*, to the *Members* of *Mens Bodies* : As *Vitruvius* in his *Third Book* : And *Albertus Durens* hath writ a whole *Book* of the *Measures* of *Man's Body*, from *Head* to *Foot* ; of which some follow :

1. The *Height* of *Man*, is equal to the distance, from one end of the *Middle Finger* to the other, the *Arms* being extended to their full length.
2. If the *Legs* and *Arms* of a *Man*, be extended *Salteir* wise, or as it is usually termed making a *St. Andrew's Cross*; If one foot of a pair of *Compasses* were placed upon the *Navel* of the *Belly*, and the other turned about, it would justly touch the *Toes* and *Fingers* of the *Man* so extended.
3. The breadth of a *Man* from one side to the other, the *Breast*, the *Head*, and the *Neck*, make the sixth part of all the *Body*.
4. The *Length* of the *Face* and *Hand* are equal.
5. The *Thicknes* of the *Body*, taken from the *Belly* to the *Back*, is the *Ninth* part of the whole *Body*.
6. The length of the *Brow*, the length of the *Nose*, the space between the *Nose* and the *Chin*, the length of the *Ears*, the greatness of the *Thumb* ; are all of them equal one to the other. But

HISTORICAL

But besides these Symetries of the *Members of Mens Bodies*, I will here insert,

The Description and Measures of all the Principal Parts of Mans Body, as they are set down by Leon Baptista Alberti, Reduced to all our English Measures; In Feet, and Hundred parts of a Foot.

	F.	Parts	
The height from the Ground to the		100	
	The <i>Instep</i> of the <i>Foot</i> ,	0	30
	<i>Ankle-Bone</i> , on the out-side of the <i>Leg</i> ,	0	22
	<i>Ankle-Bone</i> , on the in-side of the <i>Leg</i> ,	0	31
	<i>Recess</i> which is under the <i>Calf of the Leg</i> ,	0	85
	<i>Recess</i> which is under the <i>Relieve of the Knee-Bone</i> within,	1	43
	<i>Muscle</i> on the out-side of the <i>Knee</i> ,	1	70
	<i>Buttocks</i> and <i>Testicles</i> ,	2	69
	<i>Os-Sacrum</i> ,	3	00
	<i>Joynt of the Hips</i> ,	3	11
	<i>Navel</i> ,	3	60
	<i>Wast</i> ,	3	79
	<i>Tets</i> , and <i>Blade-Bone of the Stomach</i> ,	4	35
	Part of the <i>Throat</i> where the <i>Weezle Pipe</i> beginneth,	5	00
	<i>Knot of the Neck</i> , where the <i>Head</i> is set on,	5	10
	<i>Chin</i> ,	5	20
	<i>Ear</i> ,	5	50
	<i>Roots of the Hairs</i> in the <i>Forehead</i> ,	5	90
<i>Middle Finger of a Hand</i> that hangs down,	2	30	
<i>Joynt of the Wrist</i> of the said <i>Hand</i> ,	3	00	
<i>Joynt of the Elbow</i> of the said <i>Hand</i> ,	3	35	
Highest <i>Angle of the Shoulder</i> ,	5	18	

The Amplitude or Largeness of the Parts, and Measures from the Right-hand to the Left.

The	Greatest breadth of the <i>Foot</i> ,	0	42
	Greatest breadth of the <i>Heel</i> ,	0	23
	Breadth of the fullest part beneath the jettings out of the <i>Ankle-Bones</i> ,	0	24
	<i>Recess</i> , or falling in above the <i>Ankles</i> ,	0	15
	<i>Recess</i> of the <i>Mid Leg</i> , under the <i>Muscle</i> or <i>Calf</i> ,	0	25
	Greatest thickness of the <i>Calf</i> ,	0	35
	Falling in under the <i>Relieve of the Knee-Bone</i> ,	0	35
	Greatest breadth of the <i>Knee-Bone</i> ,	0	40
	Falling in of the <i>Thigh</i> , above the <i>Knee</i> ,	0	35
	Breadth of the middle or biggest part of the <i>Thigh</i> ,	0	35
	Greatest breadth among the <i>Muscles</i> in the joynt of the <i>Thigh</i> ,	1	11
	Greatest breadth between the two <i>Flanks</i> , above the <i>Joynts of the Thigh</i> ,	0	00
	Breadth of the largest part of the <i>Breast</i> , beneath the <i>Arm-Pits</i> ,	1	15

		100	
		F. Parts	
The	}	Breadth of the largest part between the <i>Shoulders</i> ,	1 50
		Beneath the <i>Neck</i> ,	0 00
		Breadth between the <i>Cheeks</i> ,	0 48
		Breadth of the <i>Palm</i> of the <i>Hand</i> ,	0 00

The Breadth and Thickness of the Arms, differ according to the several motions thereof; but the most common are these following:

The	}	Breadth of the <i>Arm</i> at the <i>Wrist</i> ,	0 23
		Breadth of the <i>Brawny</i> part of the <i>Arm</i> , under the <i>Elbow</i> ,	0 32
		Breadth of the <i>Brawny</i> part of the <i>Arm</i> above, between the <i>Elbow</i> and the <i>Shoulder</i> ,	0 40

The Thickness from the Fore-part to the Hinder-part.

The Length from the <i>Great Toe</i> , to the <i>Heel</i> ,	1 00
The Thickness from the <i>Instep</i> , to the <i>Angle</i> or <i>Corner</i> of the <i>Heel</i> ,	0 43
The Falling in of the <i>Instep</i> ,	0 30
From the falling in under the <i>Calf</i> , to the middle of the <i>Shin</i> ,	0 36
The out-side of the <i>Calf</i> of the <i>Leg</i> ,	0 40
The out-side of the <i>Pan</i> of the <i>Knee</i> ,	0 40
The thickness of the biggest part of the <i>Thigh</i> ,	0 60
From the <i>Genitals</i> to the highest Rising of the <i>Buttocks</i> ,	0 75
From the <i>Navel</i> to the <i>Reins</i> ,	0 70
The thickness of the <i>Waste</i> ,	0 66
From the <i>Teats</i> , to the highest rising of the <i>Reins</i> of the <i>Back</i> ,	0 73
From the <i>Whetstone</i> pipe, to the <i>knot</i> or <i>joyniture</i> of the <i>Neck</i> ,	0 40
From the <i>Forehead</i> , to the hinder part of the <i>Head</i> ,	0 64
From the <i>Forehead</i> to the <i>hole</i> of the <i>Ear</i> ,	0 00
The thickness of the <i>Arm</i> at the <i>Wrist</i> ,	0 00
The thickness of the <i>Brawn</i> of the <i>Arm</i> under the <i>Elbow</i> ,	0 00
The thickness of the <i>Brawn</i> of the <i>Arm</i> , between the <i>Elbow</i> and the <i>Shoulder</i> ,	0 00
The greatest thickness of the <i>Hand</i> ,	0 00
The thickness of the <i>Shoulders</i> ,	0 34

By means of these Measures it may easily be computed what proportions all the parts and Members of the Body, have one by one to the whole Length of the Body; and what Agreement and Symetry they have among themselves; as also how they vary or differ one from another; which things are most fit to be known to *Painters* and *Carvers* especially: Nor were it from the purpose to particularise how the *Parts* vary and alter, according to the several gestures incident to humane *Bodies*, as, whether they be *sitting*, or *inclining* to this or that *side*. But we shall leave the more curious disquisition into these things, to the diligence and industry of our *Artist*.

C H A P. I.

Of Men or Giants, of Prodigious Statures.

HAVING (before in this Book) given you a perfect account of the Dimensions of *Mans Body*, according to every Part and *Member* thereof, that is, of such a Body as the generality of *Men* and *Women* are, not extraordinary *Tall*, *Thick*, or *Dwarfish*, but of a middle and comely Stature; I shall now give account of some *Monstrous Giants*, which *History* makes mention of :

1. We read in the 3^d Chapter of *Dextrinomy*, of a Giant called *Ogge*, of the Town of *Rabath*; who had a *Bed* of *Iron* which was Nine *Cubits* long, and Four *Cubits* broad.

2. In the 17th Chapter of the 1st Book of the *Kings*, there is mention of *Goliath*, whose height was a *Palm* of six Inches, which is more than Nine of our *English Feet*; He was Armed from Head to Foot, whose *Curnat*, *Launce* and other *Armor* which he wore, did Weigh, of our *Weight*, at the least 500 *l*.

3. In the time of the *Grecian Wars*, after a great overflowing of the *Rivers*, *Salinus* reports, That there was found upon the Sands the *Carcase* of a *Man*, whose length was 33 *Cubits*; (which in our measure is 49 Foot and a half) a prodigious *Carcase*. For (according to the foregoing Proportions) his *Face* should be five Foot in length.

4. *Pliny* reports, That after an *Earthquake*, a Mountain being cleaven thereby, in it was found a *Body* standing upright, which was 46 *Cubits* high; some report it to be the *Body* of *Orion*, but whose *Body* soever it was, it must be *Monstrous*; for what can be thought of a *Hand* to be seven Foot, and his *Nose* two Foot and a half long.

5. *Plutarch* reports, in the *Life* of *Scutorius*, That in *Timgy*, a *Marative Town*; That because *Scutorius* could not believe what he had heard reported, caused a *Sepulchre* to be opened, and found a *Body* therein which contained 60 *Cubits* in *Length*; according to which proportion, he should be 15 of our *Feet* in *Breadth*, his *Face* 9 Foot long, his *Thumb* 3 Foot; which is neer as big as the *Colossus* at *Rhodes*.

6. It is reported by *Symphoris Campefus*, That at the foot of a Mountain near *Irepane*, in opening the foundation of a *House*, they found a *Cave* in which was found a *Giant*; which held in his hand a great *Post*, like the *Mast* of a *Ship*; and handling it, it moldred all into *Dust*, except the *Bones* which remained, and were of so vast a bigness, that the *Head* would hold 5 *Quarters* of *Corn*; by which proportion, his *Length* should be 300 Foot, the length of his *Face* 30 Foot, and his *Nose* 10 Foot.

7. *Josephus Ancofta*, in his *Italian History* reports, That at *Pern* was found the *Bones* of a *Giant* 18 Foot high: And other *Histories* are full of the *Description* of *Giants* of 9, 10 and 12 Foot high.

8. In the 58 *Olympiad*, by the admonition of the *Oracle*, the Body of *Orestes* was formed at *Tegaa* by the *Spartans*, and we understand (saith *Solinus*) that the just length of it was 7 Cubits, that is, of our Measure 10 Foot and a half.

9. In the Senate House at *Lucerne*, in the year 1584, I was shewed (saith my Author *) the fragments of some Bones of a prodigious greatness; They were found in a Cave near the Monastery of *Reiden*, under an old Oak which the Wind had then blown down: When I had considered them (saith he) though they were wasted, spunged, and light, I observed that they answered (though the Skull was not there) to the Body of a Man, and wrote upon each of them what they were, as the lowest Bone of the Thumb, a Cheek Tooth, the Shoulder-Blades, a Heel-bone, and many others, all which differed nothing from the Bones of a humane Body. These Bones I compared with a Skeleton of my own, and caused an entire Skeleton to be drawn of such greatness, as all those Bones would have made, if they had been whole and together; and it amounted to full 19 Foot in height.

* *Plat. obs. Med. l. 3. p. 584, 585.*

10. *Walter Parsons* an *English-man*, born in *Staffordshire*, he was put Apprentice to a Smith, and grew so tall, that a hole was made for him in the ground to stand in up to the Knees, to make him adequate to his fellow Workmen: He was afterwards Porter to *K. James the First*. He would make nothing to take two of the tallest Yeomen of the Guard (like the Gizard and Liver) under his Arms at once, and order them as he pleased.

11. *William Evans* born in *Monmouthshire*, and may justly be counted the Giant of our Age, for he was full 7 Foot and a half in height: He was Porter to *King Charles the first*, and succeeded *William Parsons* in his Place, and exceeded him in the height two Inches; but not so proportionable in all the parts of his Body as *Parsons* was.

G H A P. II.

Of Dwarfs and Pigmies; or Men and Women of lower then ordinary stature.

1. *Julia*, the Neice of *Augustus*, had a little Dwarfish Fellow called *Canopus*, whom she much esteemed, he was not above 2 foot and 5 inches in height; and *Andromeda*, a freed Maid of *Julia*, was of the same height.

2. Two Gentlemen, both Knights of *Rome*, as *Marcus Varro* reporteth, viz. *Marius Maximus* and *Marcus Tullius*, were either of them but 2 Cubits high, that is 3 foot.

3. *Nicephorus* in his Ecclesiastical History, saith, I saw one *John de Estrix* of *Mechlen*, when he was brought through *Bassl* to the Duke of *Parma*, then in *Flanders*, Anno 1592; He was 35 years of Age, he had a long Beard, was perfect and streight in all his Limbs, and was but 3 foot high; he could not go up Stairs, much less could he get upon a
Form

Form, but was always lift up by a Servant : He was skilled in Three Tongues, ingenious and industrious, and with him (a while) I played at Tables.

4. There was a Dwarf at *Wartemberg*, at the *Nuptials* of the Duke of *Bavaria* : He was Armed Cap a-Pee, Girt with a short Sword, and a short Spear in his hand ; He was put into a Pie, which was set upon the Table, at last, raising the Lid, he stepped out, drew his sword, and after the manner of a Fencer, traversed about the Table.

5. *Mircus Antonius* had one *Sisyphus* a Dwarf, of a vivid wit, and yet was not full Two foot high.

6. I saw (saith my Author*) in the year 1610, one *John Ducker*, an *English* Man, (whose Picture I have by me, drawn at full length) he was about 40 years of Age ; he had a long Beard, and was only 2 foot and a half high ; of streight and thick Limbs, and well proportioned.

*Plater. Obs.
Lib. 3. p. 582.

7. *Augustus Cæsar* exhibited in his Plays one *Lucius*, a Young Man ; he was not full 2 foot high ; and (saith *Ravissus*) he weighed not full 17 Pounds ; and yet he had a great and strong Voice.

8. *Cbaracus* was a man of exceeding small stature, yet was he the Wisest Councillor that was about *Saladine*, that great Conqueror of the *East*.

9. In the year 1305 *Uladislans Cabitalis* (called the *Pigmy King of Poland*) Reigned, and Fought more Battles, and obtained more glorious Victories therein, than any of his Long Shanked Predecessors. [*Vertue refuseth no Stature*] But, commonly, Vast Bodies, and extraordinary Statures, have dull, sottish and leaden Spirits.

10. *Cardan* reports, That he saw a Man in *Italy*, at full Age, not above a foot and half high carryed about in a Parrots Cage.

11. There was a *French* Man, of the Country of *Lamosin*, of about the same height, with a formal Beard, who was shewn in a Cage for Money, at the end whereof was a little Hutch into which he retired ; and when the Assembly was full, he would come out and play upon an Instrument.

CHAP. III.

Of Monsters, and other Persons, as have made entrance into the World in a different manner from the rest of Mankind.

L *Bucanon* relates of a Monster which had only one Body below the Navel, but above, two different ones ; when any part below the Navel was hurt, both the Bodies above participated of the Pain ; if above, that Body only felt it that was hurt. These two upper Bodies would sometimes quarrel, and one Dying, the other Pined away by degrees : It lived 28 years, and could speak several Languages, and was taught to play on a Musical Instrument.

II. In the year 1538. there was Born one who grew up to the Stature of a Man; he was double as to his Head and Shoulders, so that one Face stood opposite to the other: Both were of a likeness, resembling each other both in Beard and Eyes: They had both the same Appetite, and both Hungred alike: The Voyce of both was almost the same; and both Loved the same Wife.

III. *Johannes Naborowsky*, a Noble *Polonian*, had seen in his Country of *Basil*, two little Fishes. without Scales, which were brought forth by a Woman, and as soon as they came out of her Womb, did Swim in Water as other Fishes.

IV. Not long since in *Elfingorn* lived a Woman of good quality, who by her account drew near to the time of her delivery, and so provided all things necessary: But in her last Month, her big Belly seemed to be much fallen. Her time of Travel being come, and the usual Pains of Labour going before, she was delivered of a Creature very like unto a Dormouse of the greater size, which (to the amasement of the Women then present) with great celerity sought out, and found a hole in the Chamber into which it crept, and was never seen after.

V. In the year of our Lord 1639, at *Norway* we read of a marvellous Example of a Woman, who having often before been delivered of Humane Births; and again Big, and after strong labour was delivered of Two Eggs: This Womans name was *Anna*, the daughter of *Annundus*, and Wife to *Gudbrandus Erlandsonius*, who already had been Mother of Eleven Children. This *Anna*, in the year 1639, *Apr. 17.* and in the Evening of the same day, was delivered of an Egg, in all respects like that of a Hen, which being broken by the Women then present, they found that in the Yolk and White thereof there was no difference, but answered directly to a common Egg. Upon the 18th day of *April.* about noon, in the presence of the same persons, she was delivered of another Egg, in all respects like the former. This second Egg was sent to *Dr. Olaus Wormius*, to the University, in whose Study it is reserved to be seen of such as shall desire it.

VI. In the year of our Lord 1576, upon the 27th day of *December*, One *Ann Tromperin* about 30 years of Age, was delivered of a Boy and two Serpents. This Woman (saith *Caspar Barbinus*, in his *History of France*) told me upon her faith, that in the summer before, in an extrem hot day, she had drunk of a Spring in the Grove called *Brudetbolk*, adjoining to *Basil*, where she suspected that she had drank of the sperm of Serpents; she grew so big, that she was fain to carry her Belly in a Swathling-band The Child was very Lean, the Serpents were each of them an Ell in length, and thick as the Arm of an Infant, both which, alive as they were, buried by the Midwife in the Church-Yard of *St. Elizabeth*.

VII. The Concubine of Pope *Nicholas* the third was delivered of a Monster which resembled a Bear. *Mertin* the 4th, his successor, entertained the same Lady, and fearing that she should bring forth other Bear-whelps; he caused all the Painted or Carved Bears about his Palace to be

be expunged or removed : For this Pope was not ignorant how the shapes and Pictures which are conceived in a Womans imagination at the time of conception, do remain imprinted in the Body of that which is conceived.

VIII. At *Tertoghenbosch*, a City in *Brabant*, upon a solemn Festival, some of the *Citizens* disguised themselves in several habits, some like Angels, some like Devils, to augment the sport. One of these (who acted a Devils part, ran home to his house in his Devils shape, took his Wife, threw her upon a Bed, saying, he would get a young Devil upon her ; he was not deceived ; for of that copulation, there was born a Child, such as the wicked Spirit is Painted, which at his coming into the World, began to run and skip up and down the Chamber.

IX. In the Little Town of *Quiero*, amongst the *Subalpines*, upon the 17th day of *January* 1578, An honest Matron was there delivered of a Child which had upon its head 5 horns, like to those of a *Ram* : From the upper part of his Forehead there hung backwards a long piece of Flesh, that covered most part of its Back, in form like a Womans Head-lace : About its Neck was a double row of Flesh like the Collar of a Horse. At the ends of its Fingers were Claws, like to those Talons of Birds of Prey. Its Knees were in the hinder parts of its Legs : Its Right Leg and Foot were of a shining Red Colour ; and the rest of its Body all Swarthy : It came into the World with such a great Cry, that it affrighted the Midwife and the rest of the Women there present—This Monster was sent for by *Subalpinus* to his Court to be seen of him and his Courtiers.

X. In *Lesna*, the biggest Island in the *Adriatick Sea*, there was born a Monster : Below the middle part whereof, there was but one Body ; and above the middle there were Two Living Souls ; each separated from the other, with several Members ; their Heads being both of one bigness, but different in *Physiognomy* : The Belly of the one joyned to the posterior parts of the other ; and their Faces looked both one way, as if the one had carried the other on his Back ; for he that was behind would often lay his hands about the Neck of the other : Their Eyes were exceeding big, and their Hands, Thighs and Legs greater than those of an Infant of three times their age, which was but 36 days : The Excrements of both issued forth at the same place : Their Feet were round and cloven, like those of a Camel : They received their Food with an insatiable desire, and continually mourn'd with a pitiful noise : When one Slept the other waked : The Mother bought that Birth with the loss of her life, and the Monsters died soon after. This was shewn to *Lithgoe* in his Travels by a *Venetian*, the Governour of that Island.

XI. When *Fulvius Flaccus* was Consul, there was born in *Rome* of a Maid Servant, a Monster : It had Four Feet, Four hands, Four Eyes, Four Ears, and Two Members of virility.

XII. A Woman in *Prague* being with child was caused to hold a Calf while it was kill'd, and standing by while it was opened, at the falling of the Bowels she felt a commotion within her : and soon after
was

was delivered of a Boy, whose Liver, Intestines, Stomach and Spleen, with the greatest part of the Mesentery hung out beyond the Navel. It lived but a few Hours.

XIII. At *Cracovia*, (saith *Lycosthines*) in the year 1543, there was born of Noble Parents, a *Monster* with Flaming and Shining Eyes; the Mouth and Nostrils were like those of an Ox, it had long Horns, and a Back hairy like a Dogs: It had the Faces of Apes in the Breast where the Tets should stand: It had the heads of Dogs upon the two Elbows, and at the whir'l-bones of each Knee looking forward: It was Splay footed and Handed: The Feet were like Swans Feet: It had a Tail turned upwards, that was crooked backwards, and about half an Ell Long. It lived but Four hours from the birth of it; and near its death it uttered these Words; *Watch, For the Lord, your God comes.*

XIV. At *St. Lawrence* in the *West Indies* in the year 1573, there was a *Monster* born, Which (besides the horrible deformity of its Mouth, Ears and Nose; had two horns on the head, like those of young Goats; long hair on the body; a fleshy Girdle about the middle, double; from whence hung a piece of Flesh like a Purse, and a Bell of Flesh in his left hand like those the *Indians* use when they dance; White Boots of Flesh on his Legs doubled down. In brief (saith my Author, *Dr. Henry Moor*, in his *Immortality of the Soul*, P. 173.) The whole Shape was horrid and diabolical; and conceived to proceed from some Fright the mother had taken from the Antick Dances of the *Indians*; amongst whom the Devil himself does not fail, sometimes, to appear.

XV. Upon the 17th of *October* 1637, At *Boston* in *New England*, one *Mistress Dyer* was delivered of a *Monster* which had no head; the Face was on the Breast; the Ears like Apes, grew upon the Shoulders; the Eyes and Mouth stood far out; the Nose hooking upwards; the Breast and Back full of Prickles; the Navel and Belly where the Hyps should have been; instead of Toes, on each foot it had three Claws; upon the Back it had two great holes like Mouths; above the Eyes it had Four horns; It was of the Feminine Sex. The Father and Mother of this *Monster* were both great Familists, saith my Author, *Clark's Mirror*, pag. 249.

As there have been several Monsters brought into the World; So also have there been brought persons into the World (although not Monstrous, yet) in a different manner from the generality of mankind.

XVI. *Zoroastres* Laughed the same day he was born; his Brain also did so evidently pant and beat, that it would bear up the hands of those that laid them upon his head: An evident presage (saith *plato*) of the great Learning he at length attained unto.

XVII. *Nero Cæsar*, the Emperour, came into the World with his Feet foremost: Who all the time of his Reign was a very enemy to mankind.

XVIII. Some Children are brought into the World with Teeth in their heads; As *M. Curius*, and *On Papyrius Carbo*; both of them great men and honourable Personages.

XIX. Some

HISTORICAL.

9

XIX. Some are cut out of their Mothers Wombs ; As *Scipio Africanus* the first, *Julius Caesar*, *Manilius*, *Macduff* Earl of Fife, And *Edward* the Sixth of England.

XX. In the year 959. *Buchardus* Earl of *Limsgow*, *Beuchorn*, *Montfort*, and *Abbot* of *Sangal*, was vulgarly called *Unborn*, because he was cut out of his Mothers Womb.

XXI. One *Cornelius Gemma*, a *German*, says, that himself had cut out of the Wombs of Six several Women, Six living Children.

XXII. *Pliny* in his *Natural History*, speaks of a Child in *Sagnotum* (in that year it was sacked by *Hanibal*) which so soon as it was come out of the Mothers Womb, presently returned into it again.

XXIII. *Johannes Dubravins* relates of *Lewis* the Second King of *Hungary* and *Bobemia*, that there were Four things in him remarkable for haste, viz. (1) That he became Great in a short time : (2) That he had a Beard too soon : (3) That he had White hares before he was 17 years of Age : And (4) That he was born into the World without any of that Skin which they call *Epidermis* : He died *Anno* 1526. in the 29th year of his Age.

XXIV. When *Spinola* Besieged the City of *Bergopsonna*, a Woman near her time of Travel went out to draw water, at which time she was taken off in the middle by a Cannon Bullet ; so that the lower part of her fell into the Water ; such as were by, ran to her, and saw there a Child moving it self in the Bowels of the Mother : They drew it forth, and soon after brought it to *Antwerp*, where the *Infanta Isabella*, caused it to be Baptized ; and gave it the name of *Albertus Ambrosius*, One of her Fathers Captains.

XXV. *Enecho Arisza*, the first King of *Navar* being dead, *Garfas* his Son succeeded, who being one day in the Village of *Larumbe*, was surprised by some *Moorish* Robbers, assaulted and slain : they Wounded *Urracha* his Queen in the Belly with a *Launce* : The Thieves put to flight, the Queen at the Wound was delivered of a Son and dyed ; the Child was safe, and was named *Sancius Garfia* : He was well educated, proved a Valliant Man, and succeeded his Father in the Kingdom.

XXVI. The Wife of one *Simon Kneuter* of *Wessenberg* went with Child to the ninth Month, and then falling into Travel she dyed Undelivered ; those that were by doubted not but that the Child was dead also ; they disposed of the Mother as is usual ; but some few hours after, they heard a Cry ; they ran, and then found the Mother dead indeed, but delivered of a Daughter, that was in good health, and lay at her feet. *Salmuth* saith that he hath seen Three several Women, who have been dead in Travel ; and yet, after Death, delivered of the Children they went with.

To conclude these two last Paragraphs, I shall give an instance in one Person participating of both, viz.

L

XXVII. There

XXVII. There never was in any man a greater uniformity of Body and Mind (saith my Author Sir Rich. Baker) than there was in *Richard* the Third, King of *England*, for both of them were equally deformed—Of Body he was but Low, *Crook Back'd* and *Hook-Shouldred*; *Splay-Footed* and *Goggle Ey'd*; His face Little and Round; his *Complexion* Swarthy; His left Arm (from his Birth) Dry and Withered—He was born a Monster in Nature, having all his Teeth, Hair on his head, and Nails on his Fingers and Toes. And just such were the qualities of his Mind.

XXVIII. *Offa*, the Son of *Wasmond*, King of the *West Saxons*, was Tall of Stature, and of a good constitution of Body. He was Blind till Seven years of Age, and then could See: He was also Dumb till Thirty years of Age, and then spake.

C H A P. IV.

Of the length of Age which men lived in former times, shortly after the Creation, and of others of later date.

IT hath been a *Question*, what manner of *Years* those were, our Forefathers are said to have lived, as 700, 800, and 900 years, as *Methusala*, since years have been taken diversly. Some have imagined they could not be our *Anni Solaris*, as we account our years, as being a thing incredible, that the date of a mans life should extend it self to that length, far beyond the Age of the eldest Oake. Some account (as *Pliny* reporteth) every *Summer a Year*, and *Winter* another: As also the *Arcadians* counted their year by Three Months; others again by the course of the *Moon*, as the *Egyptians*; so some of them are reported to have lived 1000 years. There are those therefore that imagine those years mentioned *Gen. V.* To be understood to consist of 36 days, Ten whereof make but one *Salar year*, hereby reckoning that who are in the Scripture said to have lived 900 years, lived of our years but 90, every hundred of those Monthly years amounting but to Ten of ours. So they believed all that space of time which is contained in one year to have been anciently divided into Ten parts, and every part taken for a year, and every one of these ten parts to have had *Senarium quadratum*, because in Six days God finished his Work of the Creation; all which number multiplied by Ten, make just 12 Months. But these conclusions fall out to be most absurd, for if we consider what will follow thereupon, *Canaan*, who begat children when he was 70 years of age, should have begotten them when he was but Seven: Besides, if we make a year but of 36 days, of what length must the Month be? Surely no more then Three days: And then, How can that place in *Gen. VII. 11.* Where it is said, *The Flood began the 27th day of the second Month*? And how will it agree where it is said, *Gen. VIII. 4. The Ark rested upon the Mountains of Ararat the 27th day of the second Month*?
Let

Let us therefore certainly believe the years then to have been all one with ours, and that which is spoken of the great Age of those Fathers, not much to differ from the computation of our years. For, it is again said, *Gen. 8. 5.* That *The Mountains appeared upon the first day of the Tenth Month*; wherefore the Year consisted of many Months: And that we may not think the Month consisted but of Three days, observe, the Twenty seventh day is mentioned.

Now, If you would know the Reason, why the Fathers then lived so long. know that there are Two Causes; First, the *Final*; Secondly, the *Efficient*.

The *Final* Causes were, (1.) Increasing the World with People, whereby it might be replenished, which they could not do but by living a long time. (2.) Arts were to be invented, for they are not found but by long experience. (3.) The Worship of God was to be delivered by Tradition; for, as yet, the Written Word was not: But that could not be in such a variety of People, except those who received it from God had not been long liv'd.

The *Efficient* Causes of their length of Life were, (1.) The singular Blessings of God mentioned, *Gen. 30. 20.* *I am thy Life, and the Length of thy days.* (2.) The nearness of Time to the Creation, when the Bodies of Men were of a singular and a most perfect Constitution, Soundness, and state of Health. (3.) The Diet and Feeding was far more wholesome before the Flood, than since. (4.) The Wits and Invention were more accurate and subtil in searching and finding out the Nature and Qualities of all Things whereof they had need to the sustenance of Life, than ours are in these days: And for these Reasons, it may be supposed their Lives were extended to that length.

Neither may we wonder at it, since Heathen Writers testify, That even in their times, some Thousands of years after the Flood, many lived 200, others 300 years: Of some of which, as also of others of later date (even to this present Age) I shall give the Reader an Account:

I. *Hellanicus* (cited by *Pliny*) reports, That in *Ætolia*, many lived till they were 200 years of Age, which *Damastes* confirmeth, while he maketh mention of one *Pictoreus* amongst them, who lived strong and able of Body, till he had fulfilled 300 years.

II. *Sir Walter Raleigh*, in his Discovery of *Guinea*, reports, That the King of *Aromasia*, being 110 years of Age, came in a Morning on foot to him from his House, which was 14 *English* Miles, and returned on foot the same day.

III. *Buchanan* in his *Scotch* History; speaks of one *Lawrence*, who lived in one of the *Orcadean* Islands, Married a Wife after he was above 100 years of Age, and that when he was 120 years old, he doubted not to go a Fishing in a Rough and Tempestuous Sea.

IV. *Sigismundus Polcastrus*, Physician at *Padua*, Read there 50 years; in his old Age he buried four Sons in a short time; at 70 years of Age he Married again, and by this second Wife had three Sons; the eldest of which, called *Antonius*, he saw dignified with a Degree in both *Laws*:

Jerome, another of his Sons; had his Cap set upon his Head by the Hand of his Aged Father, who trembled, and wept for joy; not long after the old Man died, Aged 94 years.

V. *Fælix Platernus* saith, That in *Anno* 1572, his Father *Thomas Platernus* buried his Wife, which was *Fælix's* Mother, and at the 73 year of his Age, Married a second Wife, and within the compass of 10 years had six Children by her, two Sons and four Daughters; the youngest of the Daughters was born in the 81 year of his Age, and he died in the 83 year of his Age. Now that which is memorable between two of his Sons is: I *Fælix* was born *Anno* 1536, and my Brother *Thomas* 1574, the distance 38 years; and yet this Brother of mine, (to whom (for Age) I might have been Grand-father) is all Grey, and seems elder than my self.

VI. *M. Valerius Corvinus*, lived 100 years, between whose first and sixth Consulship there was 47 years; yet was he sufficient, not only for the most important matters of the Commonwealth, but also for the exactest cultures of his Fields.

VII. *Mitellus* was of the like Age, and was very old when created Pontiffe: For 22 years he had the ordering of the Ceremonies: His Tongue never faltered in solemn Prayers; nor his Hand tremble in offering the Sacrifices.

VIII. *Nicholaus Leonicensis*, was in the 96 year of his Age, when *Lan- gius* heard him at *Ferrara*, where he had taught more than 70 years.

IX. *Missaniffa* was the King of *Numidia* 60 years together, and excelled all other Men in strength. *Cicero* saith, That for no Cold or Rain he could be induced to cover his Head; He would continue standing in one and the same place, not moving a foot till all about him were weary; and when he was to transact any business sitting in his Throne, he would persist oftentimes the whole day, without turning his Body on this or the other side for a more easeful Posture: He would Lead his Army Day and Night: After the 86 year of his Age he begat a Son, whose name was *Methimnatus*, and died in the 91 year of his Age.

X. *Xenophilus*, the *Pythagorian* Philosopher, and of great Learning was 90 years of Age, and (as *Aristoxenus* saith) died free of all those incommodities that attend upon humane Life.

XI. *Lemnius* tells us of one at *Stockholm*, who at the Age of 100, Married a Wife of 30, and begat Children of her: He looked so fresh, that those that knew him not, deemed him to be not above 50.

XII. *Isocrates*, in the 94th year of his Age put forth his Book *Panathenæicus*, and lived 15 years after it, in which time he was sufficient for any work he undertook, both in Judgment, Strength and Memory.

XIII. The

XIII. The Men of the County of *Cornwall* in *England* are more hardy and strong, also very Healthy and Long Liv'd, 80 and 90 years is ordinary: To instance in some of them:—One *Polzew* lived 130 years, and a Kinsman of his 112.----One *Beansham* 106.----And one *Brown* an *Irish-man*, but a *Cornish Beggar*, who lived 120 years; upon whom a Gentleman of this County made this Epitaph:

*Here Brown the quondam Beggar lies,
Who counted (by his tale)
Some Sixscore Winters and above,
Such Virtue is in Ale:
Ale was his Meat, his Drink, his Cloth,
Ale did his death reprove;
And could he still have drank his Ale,
He had been still alive.*

In one Parish of this County in the Reign of *Q. Elizabeth*, there died in 14 Weeks space four People, whose Ages added together made 340 years.---And farther, One *Mr. Chamond* who lived at *Stratton*, was Uncle, and Great-Uncle to at the least 300 Persons.

XIV. One *Mr. Macklane*, Parson of *Lesbury* in the County of *Northumberland*, who died about the year of our Lord 1658, did in the 1656 renew his youth; so that (though 40 years before he could not read without Spectacles, being 116 years of Age) he could then read the smallest Print without them: His Hair, which before he had lost, came again as a Childs.

XV. In the Parish of *Aldbury* in the County of *Shropshire*, lived one *Thomas Parre*, who was 152 years old, who about two years before he died, was sent for up to *London* to *White-hall*, by *K. Charles* the First, and died there *Anno Dom. 1635*.

XVI. One *James Sands* of *Harborn* in the County of *Staffordshire*, lived 140 years, his Wife 120: He out-lived Five Leases of 21 years a-piece, made unto him after his Marriage.

CHAPTER V.

An Account of the first Authors of divers famous Inventions.

THE first Invention of Printing is attributed by *Peter Ramus* to one *John Faust* a *Magnutine*; for he tells us, that he had in his keeping, a Copy of *Tully's Offices* Printed upon Parchment, with this Inscription at the end of it, *viz. The excellent Work of Marcus Tullius, I John Faust a Citizen of Mentz, happily imprinted, not with Writing Ink,*
or

or Brass Pen, but with an excellent Art, by the help of Peter Gernesham, my Servant: Finished it was in the year 1466, the 4th of February. Of this Book there are divers Printed Copies seen, by several, for Pasquier saith he had one: Sadmuth saith, there is one in the Publick Library of *Ausburg*; another in *Emanuel Colledge* in *Cambridge*; another in the Publick Library at *Oxford*: And another of them is (or lately was) in the possession of my worthy Friend, Dr. *Francis Barnard* in *London*.--*Polider Virgil*, from the Report of the *Megamines* themselves, attribute the Invention of this Art to *John Gutenberg* a Knight, dwelling at *Mentz*, Anno 1440, and with him agree divers Learned Men; But the forementioned *Faus* (from him) was the first that made proof thereof in Printing of Books, and by what is before said, *Tally's Offices* was the first Book Printed that we have any Record of.---It was first brought into *England*, and practised in *London* by one *William Caxto* Mercer, in the year 1471. As concerning the Printing used in *China* above 1600 years before, it is quite different from what we use now in *Europe*: For whatsoever they Print, is first cut out in Wood, and Inked over with a Ball of Cloath, upon which the Paper being laid, they rowl over with a wooden Rowlet covered with a soft Woollen Cloath: which is no other than as Card-Makers Print their Cards; and those that make Patterns for Women and Children to Work by do.

II. Guns, Sir *Walter Raleigh* will have them to be found out by the *Indians*:---*Petrach* and *Vulturius* will have it to be the Invention of *Archimedes*: But the Common (and most received) Opinion is, That it was first found out by a Monk of *Germany*; who, by chance, a spark of Fire falling into a Pot of *Nitre*, which he had prepared for some Chymical Experiment, it caused it to fly upwards: He thereupon made a Composition, which he enclosed in an Instrument of Brass or Iron; and putting Fire to it, found his conclusion to take effect. The first Publick use of Guns (says *Magius*) was about the year 1380, or 1400 (says *Ramus*) at a Battel between the *Genoways* and the *Venetians* at *Cledia Fassa*; where the *Venetians* so galled their Enemies, that they saw themselves wounded and slain, and knew not by what means.

III. The Mariners Compass, an admirable Invention, of which the Time when, and the Author who, is uncertain. Dr. *Gilbers* of *Oxford*, who hath writ a Large and Learned Discourse of the *Load-stone*, seems to be of Opinion, that *Paulus Venetus* brought the Invention from the *Chineses*.---*Oforius* refers it to *Gama* a *Portugal*.---*Goropius Becannus* attributes it to the *Germans*, because the 32 Points of the Compass receive their names from the *Dutch* in all Languages.---But *Blondus*, who is therein followed by *Pancirollus*, will not have *Italy* lose the praise thereof, telling us, that about the year 1300, it was found out at *Melphis*, a City in the Kingdom of *Naples*, but *Blandus* names him not; and the other, *Poncirollus* says, he is not known: Yet *Salmuth*, out of *Cicrus* and *Gomara*, confidently attributes it to *Flavins*, and so doth *Du Bartus*; whose Verses upon this matter (as they are Translated by *Silvester*) are,

*We're not so much to Ceres bound for Bread,
Neither to Baccus, for his Clusters Red;*

As

As Siegnior Flavio to thy witty Trial,
 For first inventing of the Sea-mans Dial:
 The Use of th' Needle turning in the same;
 (Divine device! O admirable Frame!)
 Whereby through th' Ocean, in the darkest Night,
 Our hugest Carracks are conducted right:
 Whereby we're steer'd with Troughman, Guide and Lamp,
 To search all Corners of the Watry Camp:
 Whereby a Ship that Stormy Heavens have whield
 Near (in one Night) unto the other World,
 Knows where She is, and in his Chart descries
 What Degrees thence the Æquinoctial lies,

IV. Sailing Coaches were the Invention of *Simon Stevinus* in the Netherlands. Of one of these Coaches *Peireskius* made tryal of its swiftness in the year 1606, (after his Victory at *Newport*) he put himself, together with *Francis Mendoza* his Prisoner, into one of them at *Scheveling*, and within two hours they arrived at *Putten*, which is above 40 Miles.

V. Dice, Ball, Cards, Tables, Chess, Draughts, and such like Games, were first invented by the *Lydians*.

VI. The *Phenicians* are said to be the first Builders of Ships; They first invented open Vessels.—The *Ægyptians*, Ships with Decks; and Gallies with two Banks of Oars on a side.—Great Ships of Burthen, were first made by the *Cyprians*.—Cock-Boats and Skiffs by the *Illyrians* and *Libinians*.—Brigantines by the *Rhodians*.—Frigats or Light Barks by the *Cyrenians*.—Men of War, by the *Pamphilians*.—As for Tackle, The *Bœotians* invented the Oar—*Dædalus* of *Crete*, Masts and Sails—*Anacharsis*, Grapling Hooks—The *Tuscans* Anchors—*Typhis*, the Rudder, Helm, and Art of Steering.

VII. The *Sicilians* (saith *Pliny*) were anciently famous for Invention, as Hour-Glasses, called *Clepsira*: Military Engines, brought to great perfection by *Archimedes*—*Palamedes* first instituted Centinels in an Army, and the Watch-word.—*Penthesilea*, Queen of the *Amazons*, first invented the Battel-Axe.

VIII. The Inhabitants of *Sidon* are said to be the first makers of Glass; the Materials for the Work being first brought over from the Sands of a River running not far from *Ptolomais*, and only made Fusible in this City. The Mystery of making of Glass here in *England* was brought over by one *Benault*, a Foreign Bishop, in the year 662.

IX. To the *Flemings* is attributed the making of Cloath; Arras-Hangings; Dornix and Tapestry, Musical Instruments, Cloaks, Watches, Coaches, Chariots, Painting in Oil; Nealing upon Glass, &c. The first that brought Cloathing into *England* was *K. Edward the 3d*, by Transporting some Families of Artificers from *Gant*.hither.

X. Bra:

R E C R E A T I O N S

X. *Brachygraphy*, or the Art of Writing Short by Characters, is said, by Dion, to be invented by *Mecenas*, the great favorite of *Augustus Cæsar*, *ad celeritatem scribendi*; for the speedy dispatch of Writing.

XI. The Baking and Boyling of Sugar, as it is now used, is not above 200 years old, and the Refining thereof more new. It was first found out by the *Venetians*.

XII. Of Paper; That which was first in Use, was the Invention of the *Ægyptians*; for on the Banks of the River *Nilus*, grew those sedgy Weeds called *Popyri*, which have since given the Name to Paper. By means of this Invention *Ptolomy Philadelphus* was inabled to make his excellent Library at *Alexandria*. After this (these sedgy leaves being prohibited to be transported out of *Ægypt*) *Attalus*, King of *Pergamus*, invented the use of Parchment, made of the Skins of Sheep and Calves, from the Materials called *Membrana* and *Pergamena*, from the Place where it was invented. The convenience hereof was such, that in short time the *Ægyptian* Paper, was worn out of use, in place whereof succeeded the Paper we now use made of Rags; The Author of which excellent Invention is not left by our Ancestors to Posterity: But the Lord *Bacon* reckons it amongst the singularities of Art, although it derives its Pedigree from the Dung-hill.

XIII. Of all the Inventions and Productions of Humane Wit, that of *Writing* is the most admirable and Useful: For by means thereof, a man may Copy out his very thoughts; utter his mind without opening his Mouth; and signifie his pleasure at any distance howsoever remote; and all this by the help of 24. Letters, and in some *Alphabets* fewer: By the Various joyning and combining of which, all words utterable or imaginable may be framed: For the several varieties or changes of these 24 Letters, as *Clavius* hath computed (and it is easie to do, though laborious) to amount to.

5852616738497664000.

So that all things that are, or were, or can be imagined to be, may be expressed and signified by help of this marvelous *Alphabet*. This Miracle of Inventions hath lost its Master, for it is set down by *Thomas Read* among the *Inventa Adespota*, And thus sung by him.

*Quisquis erat, meruit senii transcendere metas,
Et fata nescire modum, qui mystica primus
Sensa animi docuit, Magicis signare Figuris.*

In English thus.

Who er'e he was, that first did shew the way,
T' express by such like *Magick* Marks our Minds;
Deserv'd reprieve unto a longer day,
Than Fate to Mortals mostly hath assign'd.

XIV. Notwithstanding the Invention of Letters is attributed to the *Phœnicians*, As *Sandy* in *Christ's Passion*, *Act. 1.*

Phœnicians, who did first produce
To Mortals, *Letters*, and their Use.

The

The *Phœnicians* inhabited between the Great Sea and *Gabie* (so called of *Phœnix* their King, the fifth in descent from *Jupiter* :) honoured for the invention of *Letters* : As *Lucan*, Lib. 3.

Phœnicians first express (if Fame be true,)
The fix'd Voice in rude *Figures*. *Memphis* knew
Not yet how Stream-lov'd *Biblus* to prepare :
But *Birds* and *Beasts*, carv'd out in stone, declare
Their *Hieroglyphick* Wisdom.—

And these Letters *Cadmus*, the Son of *Agenor*, communicated to the *Grecians*.

XV. The first Invention of the Artificial Sphere or Globe is not evidently know ; some think (with *Pliny*) that it was found out by *Atlas*, and carryed into *Greece* by *Hercules* : Others have ascribed it to *Anaximander Milesius* : Some to *Musæus*, as *Diogenes Laertius* : And some to other Authors, amongst whom *Architas Tarentius* is not forgotten. But all these were outstript by *Archimedes* the *Syracusan Mathematician*, who flourished *Anno Mundi* 3739, and before the Nativity of *Christ* 209 years : It was he that composed a Sphere of transparent *Glass* : Of which you have a description in this Treatise. Sect. Par. 3.

Of such like Spheres *Peter Ramus* sayes he saw two at *Paris*, yet not of *Glass* but of *Iron* ; the one of which *Ruellius* the *Physician* brought from the *Spoils* of *Sicily* : The other *Orontius* the *Mathematician* recovered from the *German Wars*.

XVI. *Bells* are imagined to have been invented in the year of our Redemption 400, by *Paulinus* Bishop of *Nola*, a Town in *Campania*, where *Augustus* died : They were called by the Name of *Campana*, because they were invented in *Campania* ; and the Lesser Bells *Nola*, from the Place where they were made—The Use of Bells is very great, for by the benefit of them the Hours of the time of the Day or Night are heard a far off, whether we lye in our Beds, be abroad in the Fields, or journeying on the way, although the Sun be obscured by Clouds. Moreover, Bells call us to Divine Service : They call for help in time of Fire or other dangers or Mutinies : They call Magistrates of Cities to their Common Halls, Judges to the Bench, Scholars in Univerfities to Congregations and Disputations : And in a Word, they help us in all publick actions.—And indeed *Paulinus* that Holy and Religious Bishop, did rather reform the abuse of Bells than invent them ; and taught them to call Christians to Church to serve God, whereas in former times their chief use was (as they then imagined) to chase away Devils and evil Spirits : they hindred also Magical Inchantments, as *Tibullus* notes, when he thus writes ;

*Cantus & à curru Lunam deducere tentat,
Et faceret si non era repulsa sonent.*

For they believed, that by the tingling of Bells, that the sound of Magical Verses should be hindred from coming up to the Moon ; and when she was moved with these Verses, this Sound relieved her : in

M

which

which sense may be taken that of *Stattus Papinius, Thebaid. 6.*

—*Attenitis quoties avellitur astris,
Solis opaca soror, procul anxiliantia gentes
Aera crepant, frustra que timent—*

Bells are rung many times in Thunder, to reverberate the infectious Air; the like doth Great Ordnance shot off, as well in Thunder as in foultry and close hot Weather—The *Laconians* when their King dyed, used to beat upon Kettles, instead of Ringing of Bells. The *Africans* (especially those that are *Prester Johns* Subjects) have Bells made of Stone. The *Jews* at Funerals used playing upon Pipes, as it may be gathered out of *Matthew 9. 18, 23.* Which custom it seemed the *Romans* borrowed from the *Jews*, as appeareth by *Ovid, 1 Trist.*

Tibia funeribus convenit ista meis.

The Little Bell, which we commonly call the Saints Bell, *John Pierius* useth for an *Hieroglyphick*, Teaching Preachers of Gods Word, that to the sound of their Voice, they should lead their Lives accordingly; else like the Bell, While they call upon others, themselves are deaf and stupid; in allusion whereunto, *Beza* hath this excellent *Epigram.*

*Aera gravi cunctos, veluti Campana sonore,
Ipsa licet penitus sunt sibi surda, cicut:
Sic es recta docens alios, perversa sequente,
Quique alijs sapiens, non sapiens ipse tibi.*

And so much concerning the Invention and use of Bells.

XVII. *Lucius Papyrius* was the first that set up a Sun Dial in *Rome*, which being only of use when the Sun shined—And the hourly measure of Time was first found out by *Scippio Massala*; whereas before his time the *Romans* knew no distinction in the time of the Day, than the *Morning Noon* and *Evening*; But afterwards the said Consul. *M. Val. Massala*, beautified a Columb with a Dial near the *Rostra*, as *Varro* relateth.

XVIII. *Doxius*, the Son of *Celius*, is said to be the first that built a house in *Athens* who taking his pattern from the Nests of the Swallows, began the way of making of Houses with Clay; whereas, before, men dwelt in Caves and Caverns of the Earth.

XIX. The first that ever began to erect *Obelisks*, and consecrated them to the Sun, they having embossed or ingraven upon them certain Characters and Figures, which were the *Egyptians Hieroglyphicks*, wherein a great part of their best Learning was contained; was *Mitres*, once King of *Egypt*, who held his Court in the Royal City of *Heliopolis*, the City of the Sun: And it is said he was admonished in a Vision or Dream so to do: Some of these *Obelisks* were Stones cut out of the Solid Rock, and very large, some of them have been on every side 7 foot and a half square, at the end and in length 100 foot, as was that of *Ramses*, once King of *Egypt*.

XX. Con-

XX. Concerning the Invention, of the *Telescopic Instrument*, called the *Micrometer*, there are several Competitors ; For, *Monus. Petit*, Surveyor of the Fortifications in *France* was the first that published to the World the rough draught thereof in *March 1667*. After him, *Monus. Azout*, another ingenious *Frenchman*, published a Tract concerning the exact measurement of the Planets diameters, wherein he seems to challenge the invention of this Instrument to himself and *Monus Picard* : But last of all, a candid *English man* of our own, Mr. *Richard Townley*, does vindicate the first contrivance hereof to its true and original Author ; One Mr. *Gascoigne*, an *English Gentleman*, who was killed in King *Charles I.* Service, wherein Mr. *Townley* asserts, that Mr. *Gascoigne* made and used this Instrument before the Civil Wars in *England* ; and that Mr. *Townley* had then in his custody two or three of those Instruments first devised by Mr. *Gascoigne*, to which Mr. *Townley* himself had added some considerable improvements.

XXI. Concerning *Optick Glasses*, it is evident, by what is said relating to such Glasses either in *Plantus* or *Pliny*, is little to the discovery of the real inventor of them ; but rather that the Ancients were wholly ignorant of them ; Wherefore, we must necessarily allow their invention due to the Modern Age of the World : And where to fix it we shall now enquire.

One *Monus. Monage*, a learned and ingenious *French-man*, in his *Origi-ni della Lingua Italiana*, Commenting on the Word *Occhiali Galalei*, discourses there of the time of the invention of *Spectacles*, and there relates, that *Monus. de Cange*, had told him of a *Greek Poem*, the Manuscript whereof is now in the *French Kings Library*, wherein the *Poet* (who lived *Anno 1150*) jesting on the Physicians of those Times, says of them, in *French*, *Qu'ils tatent le Poux*, &c. That they observed the Excrements of their Patients with a Glass : But *Monus. Monage* is of opinion that this was rather a transparent Glass whelmed over the Vessel, more for the relief of their Nose against the *Stench*, than to help their Eyes.

Whether *Spectacles* were of this antiquity, as *1150* or not, is by what is already said, uncertain ; but about the *13th Century* they were known and used : For in a Letter of *Signior Redi*, Dated *Anno 1313*. He says, *I find my self so pressed by Age, that I can neither read nor write without those Glasses they call Spectacles, lately invented, to the great advantage of poor Old Men, when their Sight grows weak.*

Cursea in his *Italian Dictionary*, makes this remark on the word *Occhiale*. That *Frier Jordan* in a Sermon of his, preached at *Pisa*, *An. 1305*, tells his Auditory, *That it is not 20 years since the Art of making Spectacles was found out; and is one of the most necessary Inventions in the World.*

About the same time, *viz. 1305*, *Bernard Gordon*, a famous Physician of *Montpelier*, speaking and commending of an excellent *Eye-Salve*, concludes : That, *If this or the like will not do, They must make use of Spectacles.*

From what hath been said we may conclude, that *Spectacles* were known and used in the *13th Century*, and not much before, but who the happy man was, that was the first inventor, *Frier Spina* makes the fairest Challenge to the Invention: But those *Monkish men* (as *Jordan* amongst the rest) had this invention amongst themselves before it was

publick: and that they all had the first hint thereof from our Country-man Fryer Roger Bacon; of whom as followeth:

This Learned Fryer Bacon, who died Anno 1292, and lies buried at Oxford, did well understand all sorts of *Optick Glasses*, as plainly appears by his Book of *Perspective*; And that he not only understood the Effects of single *Plain*, *Concave* and *Convex* Glasses; but knew likewise the way of combining them, so as to compose some such *Instrument* as our *Telescope*; And this appears plainly by his own words in the fore-said Book, Part III. Dif. 2. Chap. 3.---*Greater Wonders than all these are performed by Refracted Vision; For, thereby it is easily made appear, That the Greatest Object may be represented as very Little, and contrarily---And so likewise, The most distant Objects as just at hand, and contrarily.*---
 Hereby also may we bring, the Sun, Moon and Stars down here below in Appearance, &c. And in another place, viz. in his Epistle ad Parisiensem, of the *Secrets of Art and Nature*; Chap. 5. he says,---*Glasses, or Diaphanous Bodies, may be so formed, that the most remote Objects may appear as just at hand, and contrarily; So that we may read the smallest Letters at an incredible distance, and may number things though never so small, and may make the Stars appear as near as we please:* And this I think is sufficient to prove him to be the first Inventor of *Optick Glasses*:---Yet notwithstanding, the incredible things which this Man performed, (as may be read of him in Dr. Plott's *Nat. Hist. of Oxfordshire*, Ch. 9. Sect. 2. 3.) yet was he Persecuted by the Ignorant Malicious Fryers of his Order, as practising *Magick* and *Necromancy*, for which they cast him into Prison, and there detained him for a long time, some say to his Death, in the 78th year of his Age; in which time 'tis said, no one was admitted to speak with him; and that all his *Writings*, *Books* and *Instruments* were seized and burnt. And thus leaving Fryer Bacon as the Inventor of *Single Convex* and *Concave Glasses*; I shall give an account of some other Inventors of the *Telescope* as now made and used.

Borellus has written a small Tract on this Subject, *De vero Telescopii Inventore*, wherein (Chap. 12.) he seems to give the Invention to Zacharias Joannides of Middleburg in Zealand, Anno 1590. Also he names Johannes Lipperboij, or La Prey, Anno 1609, a Dutchman also; whom Saturnus calls Lippersein.

Adrianus Metius, Mathematical Professor at Franeker says, his Brother Jacobus Metius, an Alkmaer, was certainly the first inventor of the *Telescope*. And if we believe the *Italians*, we shall have the Honour of inventing this Instrument conferred on the incomperable Galileo: But he himself (in his *Nuncius Sidereus*) confesses that the first intimation he received of this Instrument, was, that a *Dutchman* had then lately made one; which set him (Galileo) upon the thought how to effect it, which he successfully discovered by the consideration of *Refraction*, and found, that a *Concave* and a *Convex-Glass* rightly adapted, would perform what he only heard in general of the *Dutch* Invention:--- But certainly, the first publick notice of this Contrivance, came from some of the fore-mentioned *Dutch-men*, and therefore is the Instrument deservedly call'd *Tubus Batavus*: Although we must confess, at the same time, that Galileo, Anno 1610, did first apply this curious Instrument to *Celestial* Ob-
 ser-

servations, and had then made such wonderful discoveries in the Heavens thereby, that all his Philosophical Successors have ever since attempted to climb higher, by lengthening their Ladder, and advancing this Instrument by many Degrees.

XXII. Of the *Microscope*: *Franciscus Fontana*, in his Book Entituled, *Cælestium Terrestriumque Rerum*, challenges to himself the invention of the *Double Microscope*; 'Tis true, that he was the first that published *Microscopical Observations* of some few Bodies, in the year 1618. After him *Borellus*, Anno 1650; Next, Dr. *Power*, a Learned *Englishman* 1664. All these went no farther then Verbal Description: But the Learned and Ingenious Mr. *Hook*, in his *Micrographia*, Printed Anno 1665, hath presented to the World curious and lively *Schemes* of several *Creatures*, and other curious Enquiries. And the Learned Dr. *Grew*, and the excellent *Bononian* Philosopher, *Marcellus Malpighius*, have laboured most successfully in the *Anatomy of Plants* by the *Microscope*: The last Author that has professedly treated of *Microscopick Observations*, is *Johan. Fran. Griendelius*, in his *Micrographia nova Norimberg*, 1687. wherein he hath taken a great deal of pains in giving the Genuine representations of his *Objects* as Magnified: And (to conclude this matter) says my Author, *Will. Molyneux* of *Dublin* Esq, "I have been often
"delighted with the curious appearance of many *Objects* seen through
"the *Microscope*; But none ever surpris'd me more, than the visible *Cir-*
"culation of the *Blood* in *Water-Newts* (*Lacerta aquatica*) to be seen as
"plainly as *Water* running in a *River*, and proportionably much more
"rapid.

XXIII. Of such *Cælestial Discoveries* as have in this our Age been made by the help of *Telescopes*.

AS to the first Inventors of *Concave* and *Convex Optick Glasses*, and how they came first to be adapted to *Telescopes*, I have in this Book made enquiry into; wherein I at last conclude *Galileo* to be deservedly reputed the first that rais'd up this *Gigantick Instrument*, that ventures to climb Heaven, and from thence brings down the Stars.

And now to recreate my Reader, I shall here recite some such discoveries as have been made in the *Heavens* in this our Age, by help of these *Telescopes*: And I shall begin my Discourse with the remotest Heavens, namely with the *Fixed Stars*, and from them gradually descend down to this our *Terrestrial Ball* by us inhabited. And,

I. Of the *FIXED STARS*.

THAT Whitish Band or *Zone*, commonly known and called by the name *Galaxia*, or the *Milkey Way*, that so irregularly incompasses a great scope in the *Heavens*, and of which the Ancients could give no tolerable Account, is found by the *Telescope* to be no other, than an heap of very minute *Stars* thickly set together; which, by their *Great Distance*, *Smallness* and *Closeness*, appear to the naked Eye, as one united whitish Cloud.

Like-

Likewise those Stars which we call *Nebulus*, as the *Head of Orion*, the *Crib in Cancer*, &c. are found to be a *Congeries* of small Stars closely set together, but easily distinguishable by the *Telescope*.

The *Pleiades*, or *Seven Stars* (though scarce more than *six* appear) are found by an ordinary *Glass*, to be nigh *Forty*: And in that one *Constellation of Orion*, the *Telescope* discovers more *Stars* than the naked *Eye* can number in all the *Heavens*.

II. Of S A T U R N.

THis *Planet* by his slow *Motion* takes *Stare* upon him, as carrying a-
bout him something more weighty than ordinary; But our short
sight perceives nothing thereof, only a plain *Round Globe*, as the rest
of the *Chorus* Dancing round the *Sun*: All his *Equipage* and *Atten-*
dants are hid from our view, till surveyed more closely by the *Telescope*;
by which you may perceive a mighty *Ring* parallel to the *Equator*, Bright
as the *Planets* own *Face*, encompassing round his *Body*; very *Thin*,
and separated in all appearance on all sides from his *Globe*: Sometimes
appearing *broader*, sometimes *narrower*; and sometimes almost *vanishing*.
Then again returning by a regular *Period*, and resuming by degrees its
former shape; which again by degrees it loses according to its own *Pe-*
riodical Motion.

But this is not all his *Equipage*; For, besides this *Throne of Light*,
this *Majestick Planet* is attended by a *Guard of Five Satillets*, that fol-
low his *Motion*, and *Dance* round him continually in a *Circle*; And
these were first discovered by *Galileo* in *October 1610*, but his *Glasses*
were too short to give the true shape of this *Planet*: But when the
Telescope was farther advanced by *Christopher Hugenius*, to 12 *Foot* in
length, and afterwards, *Anno 1656*, he doubled that length, and then
Published a *Treatise* entitled *Systema Saturnum*, in which the *Satillet*
which he discovered is the fourth from *Saturn*, of which he there gives
us the *Epoche* and *Theorie* of its *Motion*.

The other four *Satillets* were since discovered by *Monsieur Cassini*,
in this *Order*, The *Third* and *Fifth* were first seen by him *Anno 1671*,
72, and 73, by a 17 *Foot Glass*: But the innermost, or *First* and the
Second were not seen by him till the year 1684, at which time having
procured *Glasses* of an extraordinary *Length*, as 80, 100, 150, and 200
Feet; the vast *Distance* and *smallness* of these *Planets* could no longer
conceal them from his sight: And since he hath made *Tables* of the *Mo-*
tions of all *Saturns Satillets*, together with their *Distances* from *Saturn*
correspondent to their *Periodical Times*.

III. Of J U P I T E R.

JU P I T E R next presents himself less incumbered than *Saturn*, yet
not wanting a *Courtly Train*; For though his *Guards* are but *Four*
in *Number*, yet their *size* and *brightness* shew their *strength*; and their
quick Motion round about him shews their *diligence*.

Galileo was certainly the *First* that discovered these *Satillets*, *Jan. 7.*
Anno 1610, and from that time to this, no more could ever be disco-
vered about him.

These

These *Satellites* are easily seen by a *Three-foot Glass*: Ever since the time of their first discovery, many curious *Astronomers* have attended their *Motion* round *Jupiter* with a diligent Eye, and have found, that sometimes falling into the Shadow of *Jupiter's* Body, they disappear; and thence emerging, they again become visible: Sometimes they are hid behind the very *Globe* of their *Great Lord*; and sometimes being just in his *Face*, his splendor overcomes theirs, and they become invisible, as a glimmering Lamp between the Eye and Sun.

John Alfons. Borellus has Published a Tract of the *Theoricks* of these *Satellites*, Anno 1666; but none have laboured more to reduce the Observations of these little Planets to something of *Use* and *Advantage* to the World, than the two Peerless *Astronomers* of this present Age, viz. *Cassini* and *Flamsteed*.

Besides these *Four Little Moons* about *Jupiter*, the *Telescope* discovers other Remarkables even in his *Body*: As first, His *Face* is not all of a *Colour*; but there are in it *Brighter* and *Darker Parts*; and these are drawn a-thwart him, like broad *Zones* or *Belts*, almost parallel to the *Ecliptick*, as is expressed in this Figure:

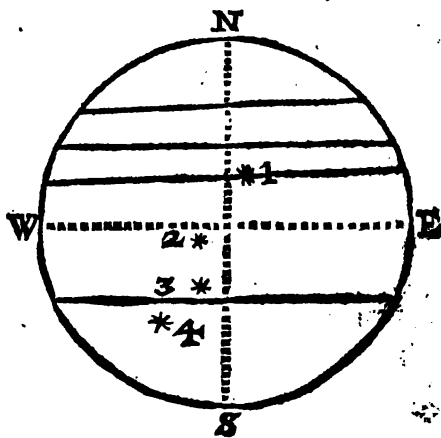

IV. M A R S.

MA R S offers himself next, who trusting in his own Strength, is attended by no Guards: But the prying *Telescope* discovers in his *Face*, *Scars*, *Spots* and *Ruggedness*.

By these *Spots* the acute *Cassini* has determined that he turns on his own Axis once in 24 hours and 40 minutes, though others assign his *Revolution* performed in just half that Time.

The *Increase* and *Decrease* in *Light* like our *Moon*, is very visible in this Planet *Mars*; who in his *Quadratures* with the *Sun*, and his *Perigeon*, may be seen almost *bisected*, but never *Corniculated* or *Falcated*, as the other *Inferiors* do: But this *Bisection*, and *Increase* and *Decrease* in *Light*, in regard of the great distance above the *Sun* cannot be seen in *Saturn* and *Jupiter*.

V. Of the S U N.

THe Sun in the next place presents it self, in whose bright Face, we can hardly expect to find *Dark Spots*, yet such there are, and frequent too, of which, and nothing else, *Schinerus* hath writ a large Book in Folio: And *Hevelius* in his *Selenography* hath many *Observations* of these *Maculae*; as also, of some *Brighter Spots* in the Sun, called *Faculae*.

The way of *Observing* them (in short) is, Either by admitting the Light of the Sun through a *Telescope* upon a sheet of *White Paper*, in a *Dark Room*; Or by Arming the Eye with a small thin *Glass* Smoaked over with a *Torch, Lamp* or *Candle*, and with it looking through a *Telescope* at the Sun's Body.

The only Discovery that has been made by these *Maculae* is, That the Sun revolves round his own Axes, in the space of about 25 days and 6 hours. And here it is to be noted, That for these several years past, the appearance of these *Maculae* has been much more rare, than when *Galileo* (who first discovered them) *Schinerus*, and *Hevelius*, &c. lived: Who attended their Observations, viz. between 50 and 60 years ago: About which time one should seldom see the Sun's Face free from one or more *Black Patches*; but now he seldom wears any, One in *Five* or *Seven* years hardly appearing.

Upon *Tuesday* the second of *July* in the year of Christ 1651, about Eight of the Clock at Night, at *Easton* in *Northamptonshire*, under the Elevation of the *North Pole*, 52 Deg. 15 Min. Dr. *John Twysden* saw in the Body of the Sun, (through an excellent *Telescope*, whose Glasses are very clean) as he relates in his *Observationes Eclipsium*, a very dark Round spot; in Diameter about the Twelfth part of the Sun's Diameter, which to his sight appeared still in the same place for a matter of *Nine* or *Ten Minutes*; tho' thin Clouds oftentime interposed and hindred him from the sight of the Sun for a short time. The *Left Margine* of the Sun was very uneven, and *Tooth'd* in the manner of a *Saw*, as in this Figure.

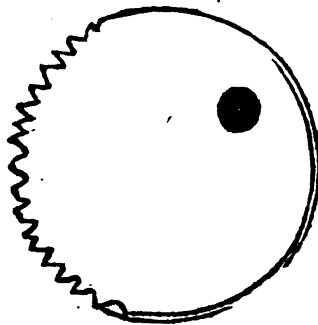

He conceived it was one of those Spots which *Galileus*, *Hevelius*, *Schinerus* and others have observed. I could not (says he) suspect *Mercury* in that place, by reason the latest Tables give him near 5 deg. of South Latitude; though in Longitude he be not far distant from the Sun: As by the several Calculations following may appear:

Locus

	Longit. ☿				Latitude ☿				Longitude ☉			
	S.	D.	M.	So.	S.	D.	M.	So.	S.	D.	M.	So.
Locus Mercurii ex Tab.	Origani,	69	8	58	0	4	10		69	19	19	16
	Argol. Ephem.	69	9	41	0	3	17		69	19	42	27
	Eichstad. Eph.	69	19	8		4	05		69	19	45	10
	Lansbergii,	69	15	48	40	3	49	14	69	20	04	03
	Britannicis,	69	18	55	01	4	51					
Vincentii Wing,	69	19	12	41	4	53						

Whatever this Spot was, of this I am certain, It was never my fortune since to see the like Spot, nor the Margine of the Sun so uneven, though I have often tryed.

VI. Of VENUS and MERCURY.

THE Brightest Planet in the Heavens; Venus fears not sometimes even at Noon-day to display her Beauty; She performs her Course alone, and free from all other Attendants.

MERCURY, Wit and Quickness secure him, therefore he hath no Train; but generally shelters himself under the Beams of his Potent Lord the Sun.

Notwithstanding, Both these Inferior Planets are found by the Telescope to Increase and Decrease, as our Moon: For, sometimes they appear Corniculated, sometimes Falcated, sometimes Gibbous, and sometimes Full; on, or near their Conjunctions with the Sun: By this last Phenomenon it is manifest they move about the Sun; sometimes farther from us, sometimes nigher to us than He; and consequently the Ptolomaick Hypothesis is evidently disconsentaneous to modern Observations.

VII. Of the MOON.

WE are now arrived at home, to contemplate our Neighbour the Moon: We may properly call her Our Moon, as making Her the Centre of her Periodical Motion: For, as the Satellites about Saturn and Jupiter move about Them; so moves the Moon as a Satellite about our Earth.

Galileo with his Telescope first discovered great Ruggedness in the Moons Face; after him Langrenus attempted to draw her Picture: But Hevelius has accurately performed that Work; in whose Schemes we may see the Moons Countenance distinguished in an admirable difference of Parts, both for Shape and Colour. We may there see greater parts that resemble our Seas, Lakes, Rivers, Islands Peninsulaes and Continents: Other lesser Spots that resemble our Mountains, Hills and Valleys: Those of the Greater parts something Obscure, may we reckon as Seas, and Lakes; and the Brighter we may account Land: For so does our Earth appear, when from a distant Height we look upon a mixture of Land and Water enlightned by the Sun; Of the smaller Spots, those that are brightest and shine, are Mountains and Rocks: And the Darker parts encompassing them we may esteem as Valleys.

Now it is manifest by the *Telescope*, That some parts of the *Moon* are much higher than others ; as that some parts of our *Earth* are higher than others. For, If you look upon the *Moon* about the *Quarter* days, we may plainly see the *Edge* towards the *Dark Part*, broken and cragged ; and many little *Bright Spots* that are clearly separated from the rest of the enlightned *Part* : Which is an evident proof, that these are the high *Tops of Eminencies*, which receive the *Suns* Light before the parts below them are enlightned. Moreover, The *Moons* Spots cast their shadows opposite to the *Sun*, that is, to the *Eastward*, whilst the *Moon* is *Increasing*, and to the *Westward* on her *Decrease*.

Now for the better distinguishing these *Spots*, and making them more useful in the *Observation* of *Lunar Eclipses*, there are *Names* imposed upon them by Authors ; *Hevelius* assigns to them the *Names* of *Places* here on *Earth* ; *Grimaldus* and *Ricciolus*, gives to them the *Names* of famous *Mathematicians* and *Astronomers* ; to the great advancement of *Geography* and *Navigation*, in settling the *Longitudes* of *Places*.

Moreover, By these *Spots* the *Moon* is discovered to have various *librating Motions*, from *East* to *West*, and from *West* to *East* ; also from *North* to *South*, and from *South* to *North*.

ALGE.

A NEW
TREATISE
OF
ALGEBRA,

According to the late Improvements.

Apply'd to *Numeral Questions* and *Geometry*.

WITH A
CONVERGING SERIES

For all manner of *Affected Equations*.

By *RICHARD SAULT*, Math. Prof.

In *Adam's Court* in *Broadstreet*, near the

Royal Exchange. *London*.

A

PRE

The first part of the document discusses the importance of maintaining accurate records of all transactions. It emphasizes that every entry should be supported by a valid receipt or invoice. This ensures transparency and allows for easy verification of the data.

In the second section, the author outlines the various methods used to collect and analyze the data. This includes both manual and automated processes. The goal is to ensure that the information is both reliable and up-to-date.

The third part of the report details the results of the analysis. It shows a clear upward trend in the data over the period covered. This indicates that the current strategy is effective and should be continued.

Finally, the document concludes with a series of recommendations for future actions. These include expanding the data collection process to include more sources and improving the reporting structure to provide more detailed insights.

P R E F A C E.

ALGEBRA depends upon the same Definitions and Axioms that a considerable part of Euclid's Elements do, and may therefore very justly be call'd a New Geometry, tho' it has no small Advantage above that, which is commonly call'd by that Name; since the Substance of whole Sciences at once are sometimes comprehended in one single Algebraic Theorem; an Instance of this the Ingenious Mr. Hally gives us in the late Transactions of the Royal Society. And in many Geometric Constructions, which otherwise would be desperate, Algebra furnishes us with such Laws and Rules, as fail not to effect to what we want. So that no one can be a good Geometrician that is not a good Algebraist; by consequence no tolerable Mathematician without it: And since Mathematics are now deservedly grown into that Repute, that they begin to be a necessary part of a Gentleman's Education, (as well as a public Encouragement of them, the Interest of a Kingdom) therefore Algebra, amongst other Parts (which in some sense may be term'd the whole) will certainly come in for a considerable Share.

As to my own Performance herein, I have omitted nothing that I know of which is useful, but have run through a whole System with what brevity and plainness I could, advancing nothing which I have not demonstrated where it's necessary, or shew'd the Reason of the Process I have applied Algebra to Numeral Questions and Geometry, and shew'd the Method of Geometric Constructions; and each of these so far, that afterwards the Learner may proceed himself to what higher Progress his own Industry and Sagacity may prompt him.

As for the Business of Equations, I have made some little Progress, which I have not seen in any other. In Quadratics I find both the Roots at once; and in Cubics I have determin'd all the sixteen Cases, and the Qualities of the Roots, as how great (near) if compar'd with each other, how many Positive, Negative, or Imaginary; and this by considering all the possible Combinations of the Coefficients arising only from three Genes, viz. from three positive Roots, or two Positive and one Negative; or, lastly, from two Negative and one Positive.

I have also given an Account of Mr. Raphson's Converging Series, with its Demonstration, and an Application of it to several Examples, sufficient to show how all Equations however high or adfect'd may be easily resolv'd, and have consider'd as previous to this Series the Punctation of Adfect'd Equations which is very useful in Common Practice; tho' now there's no absolute necessity of it, for this reaches the Case of Anticipations, a thing troublesome enough in any Exegesis Numerosa that has yet been publish'd.

I have yet two other Infinite Approximations for all Adfect'd Equations whatever, built upon very different Principles from that of Mr. Raphson's, with new Methods of Extracting Roots, and something else of this Nature, but do not think fit to publish them yet, especially since I'm inform'd that Mr. Hally has improv'd Lagny's Method for Adfect'd Equations; which I doubt not but is something worthy the Application of so good a Mathematician as Mr. Hally is, and therefore will be very welcome to the Public when he pleases to communicate it.

As for the Errata's in this Folio, in transposing it to a Quarto, (which I have printed for my own use) I have alter'd most of them; and if there be any other, which in a cursory reading over have escap'd me, I will endeavour to satisfy any Person whatever into whose Hands this shall fall, if they please to give themselves the trouble of writing to me about it.

An Explication of the Characters.

$a + b$ _____	a added to b.
$a - b$ _____	a lessened by b, or b subtracted from a.
$a \times b$ _____	a multiply'd into b.
$\frac{a}{b}$ _____	a divided by b.
$a \subset b$ _____	The Difference betwixt a and b.
$a . b :: c . \frac{bc}{a}$ _____	a is to b, as c to $\frac{bc}{a}$.
$a . b . c :: :$ _____	a, b, c, are continued Proportionals.
$a = b$ _____	a is equal to b.
$a \sqsupset b$ _____	a is greater than b.
$a \sqsubset b$ _____	a is less than b.
\sqrt{ab} _____	The Root of ab.
$\sqrt{dd+cc}$ _____	The Root of both the Quantities dd+cc.
$\sqrt{ddd+\sqrt{bb+q}}$ _____	The Universal Root of the Root of bb+q added to ddd.
$\sqrt{(3)a+b}$, or $\sqrt{a+b}$ _____	The Cubic Root of a+b, if $\sqrt{(4)a+b}$, it had been the Biquadratic; and so of all other Powers.
$\sqrt{a+b}^3$ _____	The Cube of the Binomial a+b.
$\sqrt{a+b}^n$ _____	n may signify the Index of any Power whatever of a+b.
$\sqrt{a+b}^{-1}$ _____	An Unit divided by a+b.
$\sqrt{a+b}^{-3}$ _____	An Unit divided 3 times by a+b, or by the Cube of a+b.
$c \times \sqrt{a+b}^{-3}$ _____	c divided by the Cubic Root of a+b.
$\sqrt{a+b}^{\frac{3}{2}}$ _____	The Biquadratic Root of the Cube of a+b.
$a +$	

ALGEBRA is the Science of Quantity in General. More Particularly, 'Tis an Art of Reasoning with unknown Quantities, in order to discover their Habitude or Relation to such as are known.

§. 1. **A**LGEBRA is term'd *Literal*, or *Specious Arithmetic*, in opposition to the *Numeral*, where the Figures first taken, are lost or swallowed up in others, which by several Operations are deriv'd from them; but in *Letters* the whole Process appears at first sight, and gives one *general Theorem* for all Questions of the same Nature.

§. 2. In any Operation where Letters are alike, they are supposed to be all of the same Nature, as $a, c, 3a$, &c. But different Letters suppose Quantities of different Nature, as b, c, d , &c. unless the contrary be express'd, as b & c , may be given for two Lines that are known Sides in a Triangle, but of different length.

§. 2. The *Roots* of Quantities are distinguishable by Figures prefix'd, \sqrt{ab} , or $\sqrt{(2)ab}$, signifies the Square Root of ab . $\sqrt{(3)ab}$, expresses the Cubick Root of ab . $\sqrt{(4)ab}$ the Biquadratic Root, &c.

§. 3. *Unity* is suppos'd to be prefix'd to every Quantity, as $1a$, or once a , is the same as a it self.

§. 4. If a Quantity have no Sign before it, $+$ is suppos'd to be prefix'd, as $+a$ is the same with a .

§. 5. The Sign \times has reference to the whole Quantity that follows or precedes it, if a Line be drawn over every Member thereof, as $a \times b + c + d$, or $b + c + d \times a$, where a is supposed to be multiplied into each simple Quantity b, c, d .

§. 6. A Quantity drawn or multiply'd into it self, is a Square as $a \times a = aa$; if multiply'd into its self three times, 'tis a Cube or third Power, as $a \times a \times a = aaa$; if four times, a *Biquadrat*, or fourth Power as $a \times a \times a \times a = aaaa$, &c. And so in Figures, 9 is the Square of 3, 64 the Cube of 4, &c. These *literal Powers*, when they rise high, are more commodiously express'd by the Index of the Power it self set over them; instead of aaa , we write a^3 , and a^4 instead of $aaaa$; suppose the same in the 5th, 6th, 7th, and higher Powers.

§. 7. Quantities are *Simple* or *Compound*; *Simple*, when there's but one Member, as b , or bcd , or $ddgg$, &c. *Compounds*, when connected by the Signs $+$ or $-$, as $a + b$, or $ad - ce + gg$, &c.

ADDITION of Algebraic Integers.

ADDITION finds the Sum of two or more Given Quantities. All the possible Cases in Addition are four.

1. Where Quantities have the same Sign prefix'd, and are of the same Nature.

The Reason of } It's self-evident from the ordinary way of Notation, that 2 and
the Process. } 3 make 5, whatever the things be that are added, provided they
be of like Nature; as two Men, two Lines, two like Positions, (or like

Subtraction in Algebraic Integers.

like Quantities with the Sign + prefix'd) two like Negations, (or like Quantities with the Sign - prefix'd).

To 2a	To +cc - d	To b - dd + eed	To - 10 + de
Add a	Add +cc - d	Add b - dd + 10eed	Add +3da - 16
Sum 3a + a	Sum +2cc - 2d	Sum 2b - 5dd + 11eed	Sum - 16 + 14de
or 3a			

II. Where Quantities are of the same Value and Nature, and have different Signs.

The Reason of the Process. If A has 5000 l. and owes 5000 l. it's evident that the Sum (or his whole Estate) is 0. So also in Quantities, if the Line A — B be equal to the Line B — C, and the last be subtracted from the first, (or the first lessened by the last) it's manifest that the Whole is taken away, or is equal to 0.

To 2a	To +dd - ee - f	To 13d + 25 + e + gaa + c
Ad. -2a	Add dd + ee + f	Add -13d - 25 - e - gaa - c
Sum 2a - 2a	Sum 0 . 0 . 0	Sum 0 . 0 . 0 . 0 . 0 . 0
or 0		

III. Where Quantities have not the same Value, yet are of like Nature, and have different Signs. Which is very little different from the former Case.

The Reason of the Process. If A has 5000 l. and owes 500 l. the Whole of his Estate is only lessened by so much as the Debt, that is 5000 - 500, or 4500; but if the Debt had been greater, his Estate had been -4500, or 4500 worse than nothing. Suppose the same in Quantities.

To 3a	To 3bb + 12c - dd - ef	To 29bb - 10c + d - 16g + 17
Add -2a	Add -bb - 36c + add + 12ef	Add -19bb + 2c - 20d + 17g - 15
Tot. 3a - 2a	Sum 2bb - 27c + dd + 12ef	Sum 10bb + c - 9d + 17g - 15
or a		

IV. Where Quantities are of a different Nature.

The Reason of the Process. Where Quantities are of different Species, (whether the Signs be like or unlike) they are incapable of further Connection, and must therefore be set down with their own Signs prefix'd; two Men and three Horses, make not five Men or five Horses.

To bb - cc	To d + qq + dd - b	To 13 + d
Add q + d	Add rr + ss	Add 3gg - bb
Sum bb - cc + q + d	Sum d + qq + dd - b + rr + s	Sum 13 + d + 3gg - bb

SUBTRACTION in Algebraic Integers.

SUBTRACTION finds the Difference (whether Defect or Excess) between any two propos'd Quantities.

The three Cases that occur in this Rule, are, Subtracting Quantities, whose prefix'd Signs are, (1.) + and +. (2.) + and -. (3.) - and -.

Multiplication in Algebraic Integers.

The Reason of the Process in each. } I. To take a Positive Quantity out of a Positive One, is the same thing as to subjoin the Defect of the Quantity taken; thus 3 taken out of 5, leaves 5-3, or 2.

II. To subtract a Negative Quantity out of a Positive One, is the same thing as to subtract the Subtraction, or take away the Defect of the Quantity taken; and to take away the Defect of a Quantity, is to put it in a positive State: Thus -3 taken out of 5, gives 5+3, or 8.

III. To take a Negative Quantity out of a Negative, is (as before) to take away the Negation of such Quantity. Thus -3 taken out of -5, gives -5+3, or -2.

Hence arises this general Rule for Subtraction, both in whole Numbers and Fractions.

Rule. Change the Sign or Signs of the Quantity subtracting.

From $5a$	From $3bb$	From $-3cd$	From $-dd+ee-ff$
Take $2a$	Take $-2bb$	Take bb	Take $-dd+ff$
Rem. $5a-2a$	Rem. $3bb+2bb$	Rem. $-3cd-bb$	Rem. $-dd+dd+ee-ff-ff$
or $3a$	or $5bb$		or $ee-ff-ff$

Note. That when it's doubtful whether Quantity is greater, the Difference of them is usually expressed by this Character $a > b$, and $a < b$ or $a < -b$.

MULTIPLICATION in Algebraic Integers.

MULTIPLICATION finds the Product or Rectangle of any two proposed Quantities.

Since Multiplication is nothing else but a taking the Multiplicand, so often as there are Unites in the Multiplier. Therefore,

As 1 to the Multiplier: ∴ So the Multiplicand to the Product.

Here also occur three Cases. (1.) When + multiplies +. (2.) When + multiplies -, or the contrary. (3.) When - multiplies -.

The Reason of the Process in each. } 1. In multiplying + 4 into + 5, I put or repeat the Position of 5, so often as there are Unites in the Multiplier; therefore the Total will be positive, viz. + 20.

2. In multiplying + 4 into - 5, I put the Negation of 5 four times; therefore $4 \times -5 = -20$.

And in the Converse, in multiplying - 4 into + 5, I deny the Position of 5 four times; therefore $-4 \times 5 = -20$.

3. In multiplying - 4 into - 5, I deny the Negation of 5 four times; therefore it's made Positive four times, viz. + 20.

4. Multiplication is either of Simple Quantities into Simple Quantities, or Simple Quantities into Compound ones; or, lastly, Compound Quantities into Compound.

1. Simple Quantities are immediately connected.

Multipl. a into b Prod. ba	Multipl. $3aa$ into a Prod. a^3	Multipl. $-3bb$ into $-deg$ Prod. $+3degbb$	Multipl. 18 into $8de$ Prod. $18de$
----------------------------------------	-------------------------------------------	---------------------------------------------------	---------------------------------------------

2. If one Number multiplies another, the Product shall be equal to two Products made of the Multiplication of the first Number, into two parts of the second divided at pleasure: Let 4 multiply 7 for a Product, divide 7 into any two parts, $3+2$, and multiply each part by 4 for two more Products; Then,

Division in Algebraic Integers.

$$\left. \begin{array}{r} 7 = 5 + 2 \\ \frac{4}{4} \quad \frac{4}{4} \\ \hline 28 = 20 + 8 \end{array} \right\} \text{Hence arises the Method of multiplying a Simple Quantity into every Member of a Compound.}$$

$$\begin{array}{r} \text{Multip. } a + b \\ \text{by } c \\ \hline \text{Prod. } ca + cb \end{array}$$

$$\begin{array}{r} \text{Multip. } dd - 16 \\ \text{by } 4 \\ \hline \text{Prod. } 4dd - 64 \end{array}$$

$$\begin{array}{r} \text{Multip. } 8 - 3 \\ \text{by } 6 \\ \hline \text{Prod. } 48 - 18, \text{ or } +30 \end{array}$$

3. If two Numbers be divided, each into two parts, the Product of the Whole shall be equal to the several Products arising by the Multiplication of all the Parts of the one into all the Parts of the other. Let 7 multiply 8 for a Product, divide 8 into 6 + 2, and 7 into 4 + 3. Then,

$$\left. \begin{array}{r} 8 = 6 + 2 \\ 7 = 4 + 3 \\ \hline 56 = 24 + 8 + 18 + 6 \end{array} \right\} \text{Hence arises the Method of multiplying every Member of the Compound Quantity into every Member of another.}$$

$$\begin{array}{r} \text{Mult. } a + b \\ \text{by } a + b \\ \hline aa + ab \\ ab + bb \\ \hline \text{Prod. } aa + 2ab + bb \end{array}$$

$$\begin{array}{r} \text{Mult. } aa + cc - dd \\ \text{by } aa - cc \\ \hline a^2 + a^2cc - a^2dd \\ - a^2cc - c^2 + ccdd \\ \hline \text{Prod. } a^2 - a^2dd - c^2 + ccdd \end{array}$$

$$\begin{array}{r} \text{Mult. } bcd - 16 \\ \text{by } 4 + cc \\ \hline 4bcd - 64 \\ - c^2bd - 16cc \\ \hline \text{Prod. } 4bcd - 64 - c^2bd - 16cc \end{array}$$

The beginning of the second Book of *Euclid's Elements* demonstrates this by Lines, which I would not have omitted, but that I presum'd the Process here made use of is very evident without it.

Note. That since there's no such thing as carrying of Tens, Hundreds, &c. to the next place, as in Vulgar Arithmetic, we may begin to multiply either, at the right or left Hand, and set the Results where we please, only by observing the preceding Method, like Quantities usually happen to stand over one another, for the greater conveniency of Addition; as in the first Example, ab and ab make $2ab$; in the second, a^2cc , and $-a^2cc$ destroy each other.

DIVISION in Algebraic Integers.

DIVISION: teaches how to divide a propos'd Quantity into any assign'd Number of equal Parts.

In common Division 'tis the same thing for Value, whether in dividing 12 by 3, I give 4, or $\frac{12}{3}$ for the Quote. And hence arises the General Rule for Algebraic Division.

Rule. Set the Divisor under the Dividend Fraction-wise.

$$\begin{array}{r} \text{Divide } bc \\ \text{by } d \end{array} \left. \vphantom{\begin{array}{r} \text{Divide } bc \\ \text{by } d \end{array}} \right\} \text{the Quote } \frac{bc}{d}$$

$$\begin{array}{r} \text{Divide } aa + bc \\ \text{by } de + 10 \end{array} \left. \vphantom{\begin{array}{r} \text{Divide } aa + bc \\ \text{by } de + 10 \end{array}} \right\} \text{the Quote } \frac{aa + bc}{de + 10}$$

It frequently happens that these Quotes may be reduc'd into lower Terms by the Methods hereafter mention'd; and particularly where the Terms are great, by a Division much like that in Vulgar Arithmetic; only here as in Multiplication, it's necessary to take notice, that if + divides +, it gives + in the Quote; if + divides -, (or the contrary) there arises -; if - divides -, the Result is +: And because this depends upon the same Reasoning as that in Multiplication, I presume there's no need of Repetition.

Suppose

Of the Reduction of Fractions.

Suppose I would divide $aaa-eee$, by $a-e$.

$$\begin{array}{r}
 a-e \overline{)aaa-eee} \quad (aa+ae+ee \\
 \underline{aaa-aae} \\
 ae-eee \\
 \underline{aae-ace} \\
 ace-eee \\
 \underline{ace-eee} \\
 0
 \end{array}$$

I first enquire what Quantity multiply'd into a , (the first Member of my Divisor) will give aaa , (the first Member in my Dividend) and find aa ; which set in the Quotient, and multiplied into $a-e$, (all the Members of my Divisor) gives $aaa-aae$; which subtracted from the Homologous Term or Terms in the Dividend, leaves $ae-eee$ for a new Dividend: Then I enquire again, what Quantity multiplied into a will give ae , and find ae ; which set in the Quote, multiply'd and subducted as before, leaves $ace-eee$. Again, I enquire what Quantity multiply'd into a will give ace , and find ee ; which also set in the Quote, multiply'd and subducted as before, leaves nothing. More Examples may be these.

$$\begin{array}{r}
 a+b \overline{)aa+2ab+bb} \quad (a+b \\
 \underline{aa+ab} \\
 ab+bb \\
 \underline{ab+bb} \\
 0
 \end{array}$$

$$\begin{array}{r}
 a-d \overline{)aaa-ddd+b} \quad (aa+ad+dd+\frac{b}{a-d} \\
 \underline{aaa-aad} \\
 aad-ddd \\
 \underline{aad-add} \\
 add-ddd \\
 \underline{add-ddd} \\
 +b \\
 a-d
 \end{array}$$

If (as in the last Example) there be a Remainder when the Division is finish'd, set it Fraction-wise as in Vulgar Arithmetic.

Nota. Sometimes the Division may not be performed the nearest way, yet the Quotient will be of the same Value, and may be abbreviated.

Of the Definition, Nature and Reduction of FRACTIONS.

A FRACTION is a Part or Parts of an Unit, representing some Divisible Integer.

§. 1. The Denominator expresses how many Parts Unity is divided into, and the Numerator shews how many of those Parts are to be taken; as in $\frac{3}{4}$, Unity is divided into four Parts, and three of these four are the Value of the Fraction $\frac{3}{4}$. Hence,

1. When the Numerator is greater than the Denominator, the Fraction is greater than Unity, as $\frac{4}{3} = 1 + \frac{1}{3}$.
2. When the Numerator and Denominator are equal, the Fraction is equal to Unity, $\frac{3}{3} = 1$.
3. When the Numerator is less than the Denominator, the Fraction is less than Unity; in the Fraction $\frac{3}{4}$, 4 is not contain'd once in 3.

In the first case $\frac{4}{3}$ is call'd an *improper Fraction*; and if actually divided into $1 + \frac{1}{3}$, it is term'd a *mix'd Number*, as being part Integer and part Fraction; the last Case, *viz.* $\frac{3}{4}$ is call'd a *proper Fraction*.

§. 2. The Ratio of two Numbers, is the Quote of the Antecedent divided by the Consequent.

As the Ratio of 8 to 4 is ($\frac{8}{4}$ or) Duple, the Ratio of 4 to 8 is ($\frac{4}{8}$ or) Subduple.

Hence, if the Numerator of one Fraction be to its Denominator, as the Numerator of another Fraction to its Denominator, (that is, if their Quotes are equal) then these Fractions are equal, $\frac{8}{4} = 2 = \frac{4}{2}$.

L E M M A I.

If a Number multiply two Numbers, the Products arising are in the same proportion to each other as the Numbers multiplied. Let 2 and 4 be respectively multiply'd by 3. I say (a) $2 \cdot 4 :: (3 \times 2 \cdot 3 \times 4) 6 \cdot 12$, for by §. II. $\frac{2}{4} = \frac{6}{12}$.

L E M M A II.

If a Number divide two Numbers, the Quotes are in the same proportion to each other as the Numbers divided, let 6 and 8 be respectively divided by 2. I say, that $6 \cdot 8 :: \frac{6}{2} \cdot \frac{8}{2}$. that is $6 \cdot 8 :: (\frac{1}{2} 6 \text{ to } \frac{1}{2} 8) 3 \cdot 4$ for $\frac{6}{2} = \frac{3}{1}$.

§. III. To reduce improper Fractions to Integers.

Since any Fraction, suppose $\frac{6}{3}$, does not only signify six Thirds of Unity, but also the Third of six Unities: Therefore divide the Numerator by the Denominator, and the Quote shall be an Integer.

$$\text{Divide } \frac{12}{4} \left(= 3 \right)$$

$$\text{Div. } \frac{ab}{a} \left(= b \right)$$

$$\text{Div. } \frac{xx + 2xb + bb}{x + b} \left(= x + b \right)$$

§. IV. To reduce Integers to Fractions of the same Value.

If no Denominator is assign'd, let Unity supply the place, and it's evident the Value is unalter'd.

$$\text{Thus } 13 \text{ is made } \frac{13}{1} \quad ab = \frac{ab}{1} \quad xa + cx = \frac{xa + cx}{1}$$

But if the Denominator be assign'd, first imagine the Integer made a Fraction by Unity as before; then multiply the assign'd Denominator into both the Numerator and Denominator, the Fraction arising will keep its Value by Lemma I.

Let a have b for its Denominator, then $\frac{a}{1} = \frac{ba}{b}$. Let $bb + cc$, have $e + l$ for a Denominator. Then $\frac{bb + cc}{1} = \frac{ebb + ecc + lbb + lcc}{e + l}$; and so of all others.

From the Converse of this arises the following Case.

§. V. To reduce Fractions into lesser Terms (when possible) of the same Value.

You may, by inspection, discover what Quantity is multiply'd into both the Numerator and Denominator of the given Fraction, divide each Part by that Quantity, and the Quotes will make a new Fraction of the same Value, by Lemma II.

Thus $\frac{ba}{b}$ divided by the common Multiplex b produces $\frac{a}{1}$ or a ; and $\frac{bb + cc + lbb + lcc}{e + l}$ divided by the common Multiplex $e + l$, is reduced to $\frac{bb + cc}{1}$, or $bb + cc$ of the same Value.

$$\frac{abd}{bd} \left\{ \text{Div. by } bd \right\} = \frac{ad}{b} \quad \frac{a + a + bb}{a + b} \left\{ \text{Div. by } a + b \right\} = \frac{a + b}{1} \text{ or } a + b. \quad \frac{d + e}{dd + ee} = 1$$

Of the Reduction of Fractions.

§. VI. To reduce mix'd Numbers to Fractions of the same Value.

First (by §. IV.) make the Integral Part a Fraction, whose Denominator shall be the same with that of the Fractional Part given; and to the Numerator of this new Fraction, add the first Numerator.

$$\text{Thus } c + \frac{a}{b} = \frac{cb+a}{b}. \quad b+c + \frac{bb+cc}{b-c} = \frac{bt-cc+bb+cc}{b-c} \text{ or } \frac{2bb}{b-c}$$

§. VII. To reduce two Fractions to two Integers, which shall have the same Ratio to each other as Fractions given.

Multiply alternately the Numerator of the first by the Denominator of the second, and the Numerator of the second by the Denominator of the first, and the two Products shall be the Integers sought.

Thus $\frac{a}{b}$ and $\frac{c}{d}$ are in proportion to each other, as ac and bd . For (by Lemma I)

$\frac{a}{b} = \frac{ca}{cb}$ also $\frac{c}{d} = \frac{bd}{db}$ therefore instead of using the Ratio of $\frac{a}{b}$ to $\frac{c}{d}$ I may use that of $\frac{ca}{cb}$ to $\frac{bd}{db}$ which is equal thereto: But (by Lemma II.) $\frac{ca}{cb} : \frac{bd}{db} :: ac : bd$, w.w.&c.

$$\text{Thus } \frac{a+b}{d} : \frac{ca-dc}{db} :: 2mm+abmm. daa-ddr.$$

$$\text{Thus also } \frac{a+b}{c-d} : \frac{c+rr}{p+q} :: pa+bb+qa+qb. cc+crr+ec+err.$$

And thus, if $\frac{a+b}{c} = \frac{dd}{rr}$, then also $arr+rrb=cdd$, which will be of frequent use hereafter in the Reduction of Equations.

§. VIII. To reduce Fractions to a Common Denominator, retaining the first Value.

Multiply alternately the Denominator of the last Fraction, into both the Numerator and Denominator of the first, and the Denominator of the first into the Numerator and Denominator of the last, the two new Fractions will be of the same Value by Lemma I.

$$\text{Thus } \frac{a}{b} + \frac{c}{d} \text{ are reduced to } \frac{da}{db} + \frac{bc}{bd} \text{ that is } \frac{da+bc}{db}$$

$$\text{Thus also } \frac{aa+cc}{rr} + \frac{dp-qr}{b} = \frac{baa+bcc+dpr-err}{rrb}$$

If there be more than two Fractions to be reduc'd to a common Denominator, first reduce two of them, as above, then there will be one less than before; and so on till they are all reduc'd to one: or which is the same thing, and perhaps shorter, multiply the Numerator of each Fraction into all the Denominations of the others, for new Numerators; then multiply all the Denominators together for a new Denominator.

$$\frac{a}{b} + \frac{c}{d} + \frac{e}{f} = \frac{adf+cbf+cbd}{bdf}. \text{ And so also in Compound Quantities.}$$

§. IX. To reduce Fractions to a Common Denominator of the same Value, and in the least Terms, when it may be done.

(1.) If possible, reduce the two Fractions propos'd into the least Term, by the greatest Common Divisor, (per Lemma II.) Then multiply alternately as before, (§. VIII.) (2.) If this is not to be done; (1.) Divide the two Denominators by the greatest Common Divisor. (2.) Multiply the Alternate Numerators by these Quotes for new Numerators. (3.) Multiply either of the Denominators by its Alternate Quote for a Common Denominator.

8 Addition, Subtraction, &c. of Algebraic Fractions.

The Abbreviation here (which is of very great use) depends on this, That every Member of the New Fraction, is the Quote of every Member of the old One, (when reduc'd as above) divided by the Common Divisor of the old Denominator, viz. a ; and therefore this Fraction is equal to what it would have been by §. VIII. viz. $\frac{nr+nd+atq-qam}{aatn}$

Let $\frac{nr+d}{aat}$ and $\frac{qt-m}{ns}$ be propos'd.

a the Common Divisor.

at and n the Quotes.

$\frac{nr+nd+atq-qam}{aatn}$ the New Fraction.

as is evident by Lemma II.

These 9 Sections well understood, there is no difficulty in Addition, Subtraction, &c.

Addition and Subtraction of Algebraic Fractions.

FRACTIONS (if need be) being first reduc'd to a Common Denominator, (by Lemma I.) add or subtract the Numerators as in Integers, and set the Sum or Remainder over the common Denominator. For from the common way of Notation $\frac{1}{2} + \frac{1}{3}$ of the same thing, make $\frac{5}{6}$; also $\frac{1}{2} - \frac{1}{3}$ of the same thing, is $\frac{1}{6}$ or $\frac{2}{12}$.

Examp. 1. To $\frac{2}{3}$ To $\frac{3}{4}$
 Add $\frac{1}{4}$ Add $\frac{3}{4}$
 Sum $\frac{5}{4}$ Sum $\frac{1+3}{4}$ when reduc'd.
 To $\frac{ab+cd}{de}$
 Add $\frac{3de+2de}{de}$ } Sum is $\frac{ab+cd+3de+2de}{de}$

* Remember as in whole Numbers, to change the Sign or Signs of the Quantity subtracting.
Examp. 2. From $\frac{1}{2}$ From $\frac{ab-cc}{ee}$
 Take $\frac{2}{3}$ Take $\frac{ab-cc}{ee}$
 Rem. $\frac{1}{6}$ Take $\frac{ab-cc}{ee}$ } Rem. is $\frac{2ab-cc-ab-cc}{ee}$ or $\frac{ab-2cc}{ee}$

Multiplication of Algebraic Fractions.

§. 1. **I**N Multiplication of proper Fractions, the Product is less than either of the Factors.

Demonstr. I would multiply $\frac{2}{3}$ into $\frac{3}{4}$. From the Definition of Multiplication,

1. $\frac{2}{3} :: \frac{3}{4}$ to a fourth Proportional. But $1 \square \frac{2}{3}$; therefore $\frac{2}{3} \square$ Product; or alternately.

1. $\frac{3}{4} :: \frac{2}{3}$ to a fourth Proportional. But $1 \square \frac{3}{4}$; therefore $\frac{2}{3} \square$ Product. *was to be dem.*

§. 2. Fractions (if possible) being first reduc'd into lower Terms, multiply the Numerators together for a Common Numerator, and the Denominators for a Common Denominator.

$\frac{2}{3} \times \frac{3}{4} = \frac{6}{12}$ or $\frac{1}{2}$ in the lowest Terms. $\frac{a}{b} \times \frac{d}{c} = \frac{ad}{bc}$

Multip. $\frac{bt+acd}{r-s}$
 into $\frac{3dr-2cd}{2r}$ } The Product arising is $\frac{3drbt+3cdtr-2cdtb-4ccdt}{2r-s}$ To

Division of Algebraic Fractions.

9

To demonstrate the Truth of the preceding Rule, viz. $\frac{2}{3} \times \frac{3}{4} = \frac{2}{4}$. From the *defn.* of Multiplication, $1. \frac{2}{3} :: \frac{3}{4}$ to a fourth Proportional; I am therefore to prove that $1. \frac{2}{3} :: \frac{3}{4} \cdot \frac{4}{3}$: Or in Letters, $1. \frac{b}{a} :: \frac{c}{c} \left(\frac{ab}{ac}\right) \frac{b}{c}$ instead of 1 put $\frac{a}{a}$ equal to it, (to bring it in the same denomination with the next Term); then $\frac{a}{a} \cdot \frac{b}{c} :: \frac{a}{c} \cdot \frac{b}{c}$, that is by *Lemma II.* $a \cdot b :: a \cdot b$, which is evidently true; therefore by equality of Proportion, $1. \frac{b}{a} :: \frac{a}{c} \left(\frac{ab}{ac}\right) \frac{b}{c}$; or $1. \frac{2}{3} :: \frac{3}{4} \cdot \frac{4}{3}$, which was to be demonstrated.

Division of Algebraic Fractions.

§. I. **I**N the division of proper Fractions, the Quote is \square than either the Divisor or Dividend.

Demonst. I would divide $\frac{2}{3}$ by $\frac{3}{4}$, or the contrary: from the Definition of Division; As Divisor to Unity :: so Dividend to the Quote. Then $\frac{2}{3} \cdot 1 :: \frac{3}{4}$ to a fourth Proportional; which must be \square than $\frac{3}{4}$, because $1 \square \frac{3}{4}$. and alternately, $\frac{2}{3} \cdot 1 :: \frac{3}{4}$ to a fourth Proportional, which must be \square than $\frac{2}{3}$, because $1 \square \frac{2}{3}$; which was to be demonstrated.

§. II. Fractions (if need be) being first reduc'd to a Common Denominator in the lowest Terms, cast away such Common Denominator, and divide the Numerator of the Dividend by the Numerator of the Divisor.

Divide $\frac{2}{3}$ } the Quote
by $\frac{3}{4}$ } is $\frac{8}{9}$ For by *Lemma II.* $\frac{2}{3} \cdot \frac{4}{3} :: 8 \cdot 3$.

Divide $\frac{aa+2ab}{3d}$ }
by $\frac{bb-2ab}{3d}$ } Quote $\frac{aa+2ab}{bb-2ab}$

And so of all others, whether Fractions proper, improper, or mix'd Numbers when reduc'd to a Common Denominator.

Of the Genesis and Analysis of Powers.

§. I. **B**Y the word Powers, is meant Squares, Cubes, Biquadrates, &c. as before. By the *Genesis of Powers*, is understood a Procreation of them, arising by the continual Multiplication of some Root into it self; as if a be the Root, then $a \times a$ or a^2 is the second Power; $a \times a \times a$, or a^3 is the third Power, and so on: 'Tis the same if the Root be a Binomial, $a + b$; a Residual, as $a - b$; a Trinomial, as $a + b + c$; a Quadrinomial, as $a + b + c + d$, &c.

But the Power of a Binomial, being the most proper and easy to be resolv'd again into its Root, (which Resolution is what is meant by *Analysis*) I shall only prosecute the Generation of Powers from it. *Ex. Gr.*

$a + b$, the Root.

* $a + b$ }², or $aa + 2ab + bb$, the Square.

* See the Characters at the beginning.

$a + b$ }³, or $aaa + 3aab + 3abb + bbb$, the Cube.

D

$a + b$

10 Of the Genesis and Analysis of Powers.

$a+b$;², or $a^2+4a^2b+6aabb+4ab^2+b^2$, the Biquadrate.

$a+b$;³, or $a^3+5a^2b+10a^2bb+10aab^2+5ab^3+b^3$, the Cubiquadrate, &c.

Which Powers may be thus represented in Plano.

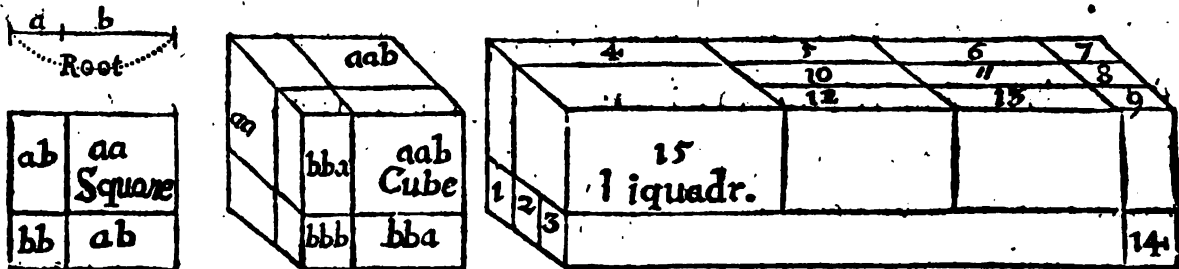

The Parts of the Square are all apparent.
The Parts of the Cube are all visible except *aaa*, which lies under the highest *aab*.

In the Bi-quadrate } 1. a^2b | 4. abb | 7. a^2b^2 | 10. a^2b^2 | 13. ab^3
the Parts } 2. a^2b | 5. a^2 | 8. a^2b^2 | 11. a^2b^2 | 14. ab^3
lie thus. } 3. a^2b | 6. a^2b | 9. a^2b^2 | 12. a^2b^2 | 15. ab^3
16. bbb , lies under 13, ab^3 . all the rest are visible.

§. II. All Higher Powers may be represented in Plano, and will be Parallelipipeds, which I have not found any one yet take notice of, only the length of them will depend upon the Value of their Binomial Root, and where we come to have a higher Power than a Cube. Suppose *bbba*, it's but multiplying *b* into its self; and let the Product extend in length; and then the two other parts multiply'd into that length, shall make up a Parallelipipedon.

§. III. From the Procces in the preceding Genesis, which is our Exemplar in all Cases that can happen, we have a Method of generating Powers from any given Root.

Suppose I would have the Square of $ad+rr$, or $ad+rr$;²; I must make it to answer the respective Parts of the Square of $a+b$. Thus,

$$\begin{array}{l|l} ad & d^2 \\ 2ab & 2d^2r \\ bb & r^2 \end{array} \left. \vphantom{\begin{array}{l|l} ad & d^2 \\ 2ab & 2d^2r \\ bb & r^2 \end{array}} \right\} \text{the Square sought.}$$

§. IV. If the Root be a Trinomial, or have yet more Members, the Case is still the same, only $aa+2ab+bb$, must be repeated so many times save one as there are Members in the given Root. For Instance, if the Root be a Trinomial, there will be two Operations.

Suppose $ad-2de+gg$;² was demanded; (1.) Square the two first Members as in the Margin. (2.) Let the two first Members be *a*, and the next be *e*, then will *aa* be equal to the Square of the two first Members, and the second Operation will be thus.

$$\begin{array}{l|l} aa & +dddd \\ 2ab & -4d^2e \\ bb & +4ddee \end{array} \left. \vphantom{\begin{array}{l|l} aa & +dddd \\ 2ab & -4d^2e \\ bb & +4ddee \end{array}} \right\} \text{The Square of the first two Members.}$$

$$\begin{array}{l|l} aa & d^24d^2e+4ddee \\ 2ad & 2ddgg-4dgg \\ bb & gggg \end{array}$$

This might have been perform'd, by squaring the whole Quantity at once; but it's done *gradatim*, for a plainer insight in the Extraction of Roots, which is only the reverse hereof, and must (ordinarily) be performed *quadratim*. But to apply this to Numbers.

The whole Square sought. d^24d^2e
 $+4ddee+2d^2g^2-4dgg+g^2$.

Suppose

Of the Genesis and Analysis of Powers. 11

Suppose $2612\frac{1}{2}$ was demanded, we are here to use the same Process as in the last Example, only 'tis necessary to have respect to the number of Places, as the Square of the first Figure 2, or 2000, will have six Ciphers after it; the Rectangle of 2 into 6, or 2000×600 , will have Ciphers. The Square of 6, or 600, is 36 with four Ciphers; and so of all others.

S. VI. The Reverse of this Procedure furnishes us with a Method for the *Analysis* or Extraction of Square-Roots.

Suppose $aa+2ab+bb\frac{1}{2}$ was demanded, (1.) I extract the Root of aa , which squar'd set in the Quote, and subducted from aa , leaves nothing.

(2.) To find the other Member of the Binomial, viz. b , I have the double Rectangle of $2ab$; a is already found, by consequence $2a$ one of the Factors; but if a Rectangle be given, and one of the Factors, the other Factor is given by Division, viz. $\frac{2ab}{2a} = b$. Having found the other Member, square it, multiply it into the Divisor, and subduct the Products from $2ab+bb$, (which must be first brought down as in common Division) and there remains nothing.

1. Hence the in extracting Square Roots, the Divisor is always twice the Quotient.
2. The *Resolvend* does always contain, or at least is equal to ($2ab+bb$, or) the Square of the Figure last set in the Quote, more two Rectangles of the last Figure into all the Quote.
3. The *Ablatium* or Number subtracting, is always $2ab+bb$ exactly.
4. From the Order and Nature of places Unity in the Divisor, will stand under Tens in the Resolvend.

But in order to discover the Square, Cubic, or Biquadratic Root of the first Punctuation (as also further if need be) in Numeral Extractions, the following Table may properly intervene here, whose Use is briefly thus.

What's the nearest Square Root of 6; this lies betwixt 4 and 9 in the Column of Squares, and therefore the next Square Root under the Truth is 2 opposite to 4. Thus the next Square Root of 79, is that of 64, viz. 8. The next Cube Root of 187, is that of 125, viz. 5. The next Biquadrant Root of 4483, is that of 4096, viz. 8, &c.

aa	4.....	$a=2$
$2ab$	24.....	$b=6$
bb	36.....	
aa	676....	$a=26$
$2ab$	52....	$b=1$
bb	1..	
aa	68121..	$a=261$
$2ab$	1044..	$b=2$
bb	4	
6822544 the whole Square of the given Root, viz. 6212.		

$$\begin{array}{r}
 aa+2ab+bb \quad a+b \\
 \underline{aa} \\
 2ab+bb \\
 \underline{2ab+bb} \\

 \end{array}$$

A Table of Numeral Powers.

√	Sq.	√	Sq.	√	Sq.	√	Sq.	√	Sq.
1	1	21	441	41	1681	61	3721	81	6561
2	4	22	484	42	1764	62	3844	82	6724
3	9	23	529	43	1849	63	3969	83	6889
4	16	24	576	44	1936	64	4096	84	7056
5	25	25	625	45	2025	65	4225	85	7225
6	36	26	676	46	2116	66	4356	86	7396
7	49	27	729	47	2209	67	4489	87	7569
8	64	28	784	48	2304	68	4624	88	7744
9	81	29	841	49	2401	69	4761	89	7921
10	100	30	900	50	2500	70	4900	90	8100
11	121	31	961	51	2601	71	5041	91	8281
12	144	32	1024	52	2704	72	5184	92	8464
13	169	33	1089	53	2809	73	5329	93	8649
14	196	34	1156	54	2916	74	5476	94	8836
15	225	35	1225	55	3025	75	5625	95	9025
16	256	36	1296	56	3136	76	5776	96	9216
17	289	37	1369	57	3249	77	5929	97	9409
18	324	38	1444	58	3364	78	6084	98	9604
19	361	39	1521	59	3481	79	6241	99	9801
20	400	40	1600	60	3600	80	6400	100	10000
√3.	Cub.	√3.	Cub.	√3.	Cub.	√4.	Biqua.	√4.	Biquad.
1	1	11	1331	21	9261	1	1	11	14641
2	8	13	1728	22	10648	2	16	12	20736
3	27	13	2197	23	12167	3	81	13	28561
4	64	14	2744	24	13824	4	256	14	38416
5	125	15	3375	25	15625	5	625	15	50625
6	216	16	4096	26	17576	6	1296	16	65536
7	343	17	4913	27	19683	7	2401	17	83521
8	512	18	5832	28	21952	8	4096	18	104976
9	729	19	6859	29	24389	9	6561	19	130321
10	1000	20	8000	30	27000	10	10000	20	160000

§. VII. To apply the preceding Extraction to Numbers.

Suppose 6822544; was demanded. After pointing of every other Figure, beginning at the right Hand, the nearest Root (under truth) of the first Punctuation, is 2; which squared, set in the Quote, and subducted from 6, leaves 2. Bring down the next Punctuation 82, then is 282 (the Resolvend) = 2ab + bb; therefore double the Quote, viz. = 2a, and thereby divide only the two first Figures of 282, to leave room for the Square of the Quote, which is part of the Ablatitium, and there arises 6; which squar'd, multiply'd by the Divisor, and the Sum subducted from 282, leaves 6.

3. Let a=26, bring down the next Punctat. 25, then is 625=2ab+bb. To

$$\begin{array}{r}
 6822544 \quad \left(\begin{array}{l} 2612 \text{ Root.} \\ 4 \dots \dots \text{ Ablatitium.} \end{array} \right. \\
 \underline{4 \dots \dots} \\
 282 \dots \dots \text{ Resolvend.} \\
 \underline{36 = bb} \\
 24 = 2ab \\
 \underline{276 \dots \dots} \text{ Ablatit.} \\
 28 \dots \dots 52 \left. \begin{array}{l} 625 \dots \dots \text{ Resolv.} \\ 1 = bb \\ 52 = 2ab \\ 521 \dots \dots \text{ Ablatit.} \end{array} \right. \\
 \underline{521 \dots \dots} \\
 28 \dots \dots 522 \left. \begin{array}{l} 10444 \dots \dots \text{ Resolv.} \\ 4 = bb \\ 1044 = 2ab \\ 10444 \dots \dots \text{ Ablat.} \\ 0. \end{array} \right.
 \end{array}$$

find

Of the Genesis and Analysis of Powers. 13

find b , Square the Quote, &c. continuing the same Operation as before through all the Punctations, and the Process will appear as in the Margin.

But since the Tens resulting in squaring 6, (the second Figure in the Quote) may be carried to the Tens in 20, (the other part of the Ablatium) therefore the Operation may be abbreviated here, though it can't (ordinarily) in higher Powers. Thus.

$$\begin{array}{r}
 6822544 \quad (2612 \text{ Root.} \\
 \underline{4} \\
 4 \overline{)282} \\
 \underline{276} \quad = 2ab + bb \\
 52 \overline{)625} \\
 \underline{521} \\
 522 \overline{)10444} \\
 \underline{10444}
 \end{array}$$

The proof of a Square Extraction. If there be any Remainder, subtract it from the Sum propos'd to be extracted, and the Remainder shall be equal to the Square of the Quote or Root found, if true, *Ex. gr.* the Root of 6094 is 78, and there remains 10 after the Extraction; extract this 10 from 6094, and there rests 6084 equal to the Square of Quote or Root 78. If there's no Remainder, the Quote squar'd will give the Sum again, as the square Root of 5625 is 75 without a Remainder, for the Square of 75 = 5615.

§. VIII. If the Quantity propos'd be not a perfect Square, it may nevertheless be continued after the same manner, by a *Converging Series*, nearer the Truth than any assign'd Quantity.

Suppose $\sqrt{aa+bb}$ was demanded :

If the Quote be continued infinitely, the same Method of procedure will continue infinitely : viz. Always square the Quantity left set in the Quote, and divide the Product by twice the whole Quote : After the two first Quantities, this will be always a Negative Series. From hence we have a new Method of extracting Square Roots;

$$\begin{array}{r}
 aa+bb \\
 aa \left(a + \frac{b}{2a} - \frac{bb}{8a^3+4ab^2} \text{ &c.} \right. \\
 \hline
 2a \overline{) b} + \frac{bb}{4aa} \\
 \hline
 2aa \overline{) -bb} - \frac{bb}{4aa}
 \end{array}$$

to an hundred Figures or more in an hour or two's Time, which by the common Methods can't be done in so many Years, perhaps not in an Age.

I have seen a small Abstract of *Father Lagny's Nouvelles Methodes*, &c. which is built (I presume) upon this Principle, and has the same Pretensions, though the Abstract was too short and imperfect to find the Reason of his Process: Also our own Ingenious Mr. *Raphson* was pleas'd to show me the same Series himself; and I doubt not but if he would allow himself Time to prosecute it, he might make the same Application, and perhaps better than I have done. Mine was this;

1. I consider'd, that in extracting the Square Root of any Figure, suppose 2; to any Number of Decimal Places, suppose 27, at the same time I extracted the Root of two hundred Millions of Millions of Millions of Millions.

2. That in extracting the Root of four Figures, I should not miss Unity, if I extracted only the Root of the two first with two Ciphers; or if of eight Figures, the Root of 4 with four Ciphers; if of sixteen Figures, the Root of 8 with eight Ciphers: and so on.

3. That in the Operation, great care ought to be taken, that the Surplusage after Extraction be added in its proper Place; and that also in subtracting the Square of the true Root from its correspondent Place, the same Caution be observed; which perhaps is easiest done, supposing all to be Decimals after the first Punctation, till the Operation be finish'd.

Of the Genesis and Analysis of Powers. 15

Let $a+b$ be demanded.

1. Set the Root of the first Member aaa in the Quote; Cube it, and subtract from aaa , there rests nothing.

$$\begin{array}{r} aaa+3aab+3abb+bbb \quad (a+b \\ \underline{aaa} \\ 3aa) 3aab+3abb+bbb \text{ Resolvend.} \\ \quad \quad \quad 3aab+3abb+bbb \text{ Ablatitium.} \end{array}$$

2. To find the other Member b , we have $3aab$; a is found already, and by consequence $3aa$; but having the whole Product $3aab$, and one of the Factors, *viz.* $3aa$, the other also is found by Division $\frac{3aab}{3aa} = b$.

Set b in the Quote, Cube it, multiply the tripple Square thereof into all the Quote, (which here is only a); multiply also the tripple thereof into the Quote (a) Squar'd; which several Products subtracted from the respective Members in the Resolvend, leaves nothing.

COROLLARIES for Cubic Extractions.

I. Hence in extracting Cube Roots, the Triple Square of the whole Quote is always the Divisor.

II. The Resolvend does always contain, or at least is $3aab+3abb+bbb$, or the Values express'd by these Letters.

III. The *Ablatitium* is always exactly $3aab+3abb+bbb$.

IV. From the Nature of the Punctations, and Order of Places, Unity in the Divisor will always stand under the Place of Hundreds in the Resolvend. I make use of no more for my Divisor than $3aa$, and thereby save some Labour; though all I ever yet saw add $3aa+3a$; but it comes all to one End.

Let $187237601\frac{1}{2}$ be requir'd.

After pointing every third Figure from the left Hand, take the nearest Cube Root of the first Punctation, by the preceding Table, *viz.* 5, which set in the Quote, cub'd and subducted from 187, leaves 62; to which bring down 237, it makes 62237 for the Resolvend.

2. Triple Square the Quote for a Divisor, *viz.* 5, which is 75. 5 will stand under 2, the place of Hundreds: So that 75 divides 622, and gives 7 for the Quote. Which cub'd, squar'd and multiply'd into the Triple of a , also multiply'd into the tripple Square of a , gives the three Products, 343, 735, 525; which set in their proper places and added,

$$\begin{array}{r} 187237601\frac{1}{2} \quad (572 \\ \underline{125} \\ 3aa \dots 75) \quad 62237 \quad \text{Resolvend.} \\ \quad \quad \quad 343 \dots \dots \dots bbb \\ \quad \quad \quad 735 \dots \dots \dots 3abb \\ \quad \quad \quad 525 \dots \dots \dots 3aab \\ \quad \quad \quad \underline{60193} \dots \dots \text{Ablatit?} \\ 3aa \dots 9747) \quad 2044601 \quad \text{Resolv.} \\ \quad \quad \quad \quad \quad \quad 8 \quad \quad \quad bbb \\ \quad \quad \quad \quad \quad \quad 684 \quad \quad \quad 3abb \\ \quad \quad \quad \quad \quad \quad 19494 \quad \quad \quad 3aab \\ \quad \quad \quad \quad \quad \quad \underline{1956248} \quad \text{Ablat.} \\ \quad \quad \quad \quad \quad \quad 88353 \quad \text{Remaind.} \end{array}$$

give 60193, the Ablatitium; to be taken out of the Resolvend 62237, and there rests 2044; to which bring the next Punctation 601, it makes 2044601, a new Re-

3. Triple Square the whole Quote 57, which makes 9747 for a Divisor to the new Resolvend as far as Hundreds; proceed as before, and there rests 68353, which shows that 187237601 contains a perfect Cube, and 88353 over and above: The Truth might be prosecuted in Decimals near, by adding Ternaries of Ciphers, *viz.* 000, and proceeding after the same manner for as many places as is required.

The proof of a Cubic Extraction is this, Take the Remainder, if any, and subtract it out of the Sum proposed to be extracted; then Cube the Quote, which will be equal to that Subtraction if true.

Example. The Cubic Root of 24489 is 29, and there remains 100; take this 100 out of 24489, there rests 24389 equal to the Cube of 29.

This Method of adding Decimals, gives but one Figure at a time in the Quote, and therefore may be much abridg'd by a *Converging Series*, which throws in 3, 6, or 12, at a time, if need be: The Method of which depends upon the Series in the following Extraction.

16 Of the Genesis and Analysis of Powers.

Let $\sqrt[3]{aaa+b}$ be demanded.

Let a signify the nearest Root of the first Punctuation, and b the Remainder; Then this Series may be express'd in words thus. If to the Cube Root (near) of the first Punctuation be added, the Quots of the Remainder divided by the Triple Square of the first Quote, lessen'd by the Quote of the Sums of the Cubes of the Quotary left placed in the Quote + 3 Parallepipedons, betwixt the Square of this last Quotary into Triple the rest of the Quote divided by the Triple Square of the whole Quote, repeated at pleasure, the Series arising shall, if infinitely continued, infinitely approach the true Value of any Cube Number.

$$\begin{array}{r} \frac{aaa+b}{aaa} \left(a + \frac{b}{3aa} - \&c. \right. \\ \frac{3aa(b + \frac{bb}{3a^2} + \frac{b^2}{27a^3})}{3aa} - \frac{bb}{3a^2} - \frac{b^2}{27a^3} \\ \left. 3 \times a + \frac{b}{3aa} \text{ Sq.} \right) - \frac{bb}{3a^2} - \frac{b^2}{27a^3} \end{array}$$

In the application of this to Numbers, great Care must be taken (as in the preceding Quadratic Series) of the Value of Places, because of adding and subtracting, and consequently finding the Place of each Figure arising in the Quote.

Note. This Method for Cubic Extractions is of little use, but when the Number given to be extracted is very large. I shall only give as small an Example as is practicable in this Method.

Let the *Cubic Root* of the mix'd Number 37.945 be demanded to four Places in Decimals, and the Operation will be as follows.

Such as please may, with a little more labour, throw yet more Decimals at a time in the Quote, if instead of the aforesaid Quadratic Series,

they use $a + \frac{ab}{2aa+b} + \&c.$

And if instead of the Cubic

they use this $a + \frac{ab}{3aaa+b} +$

$\&c.$ Which two are found by taking as much of the second and third step in each Series together as may be conveniently done.

A	B	C	
~	~	~	
37	245	0000000000	(3 a
a	b	c	3.7 b
27			3.37
27			- 00961 c
81			
190			
189			
1			
			= Rem.
			.955000 = Rem. + B
			.050653 = Cube of Quantity last placed in the Quote.
			1.2321 . . = to its triple Square x a.
			- 1.282753 Ablatitium.
34.0707			- 3277530 (-00961 = c
			3066363
			2111670
			2044242
			67428 = Rem.

Another Operation would give all the Radical Figures, if the Sum propos'd was continued to eighteen more Places.

And in like manner the *Biquadratic*, *Cubiquadratic*, &c. Roots may be very briefly extracted.

I shall pass over the Business of mix'd or adaffected Extractions, since that is much more conveniently perform'd by *Converging Series* as hereafter.

Re-

Reduction of Simple Equations.

§. 1. **A**mongst Quantities of different Values, there may be yet an Equality, as $40 s. = 2 l.$ which may be represented in Letters at pleasure; But because in Algebraic Operations, known and unknown Quantities will be indifferently mix'd and complicated, therefore it will be convenient, for an easier distinction of them, to use different Characters, as $a, b, c, d,$ &c. for such as are known; and $x, y, z,$ for such as are unknown.

§. 2. When Quantities are thus mix'd, it's necessary so to reduce them, as that the *known* may possess one Side of the Equation, and the *unknown* the other. *Ex. gr.* $\frac{ab}{c} = x$; whence by comparing them together, the Value of the *unknown* may be discovered.

§. 3. Equation are of different Kinds, according as the Root of the respective Powers of the *unknown Quantity* is compounded, viz. *Simple* (or *Lateral*) *Quadratic*, *Cubic*, *Biquadratic*, or yet higher.

§. 4. In the Resolution of *Simple* and *Quadratic Equations*, I shall make use of the common Methods, unless where the *Homogeneous Comparation*, or *absolutely known Quantity* is very great; in which Case (as well as in *Cubics*, *Biquadratics* and *higher Powers*) the new *Converging Series* is much preferable.

The *Reduction* of Simple Equations, which is first in order, may be effected, either

By ADDITION.

§. 5. **I**f equal Things be added to Equal, the Totals will be Equal. Wherefore to get the unknown Quantity x by its self one side of the Equation,

Let there be } propos'd, }	$\begin{array}{r} x - a = b + c \\ \text{Add } a \dots a \\ \hline x = b + c + a \end{array}$	$\begin{array}{r} c - x = 0 \\ \text{Add } x \dots x \\ \hline c = x \end{array}$	Add	$\begin{array}{r} a + b - x = -gg \\ \text{Add } \left\{ \begin{array}{l} x \dots x \\ gg \dots gg \end{array} \right. \\ \hline a + b + gg = x \end{array}$
-------------------------------	-----------------------------------------------------------------------------------------------	-----------------------------------------------------------------------------------	-----	--------------------------------------------------------------------------------------------------------------------------------------------------------------

By SUBTRACTION.

If equal things be taken from Equal, the Remainder will be Equal. *Ex. gr.*

$\begin{array}{r} x + a = b + c \\ \text{Sub. } -a \dots -a \\ \hline x = b + c - a \end{array}$	$\begin{array}{r} dd + cc = qq + 10 + x + 10d + \frac{1}{2} \\ \text{Sub. } -q^2 - 10 - 10d - \frac{1}{2} \dots -q^2 - 10 - 10d + \frac{1}{2} \\ \hline dd + cc - q^2 - 10 - 10d - \frac{1}{2} = x \end{array}$
--------------------------------------------------------------------------------------------------	-----------------------------------------------------------------------------------------------------------------------------------------------------------------------------------------------------------------

Not. These two ways of Reduction, viz. by *Addition* and *Subtraction*, are compendiously perform'd by transposition of Quantities to the other Side of the Equation with contrary Signs; as in the preceding Examples.

$\begin{array}{r} x - a = b + c \\ \text{Then, } x = b + c + a \end{array}$	$\begin{array}{r} ab - x = -gg \\ \text{Then, } ab + gg = x \end{array}$	$\begin{array}{r} dd + cc = qq + 10 + x + 10d + \frac{1}{2} \\ \text{Then, } dd + cc - qq - 10 - 10d - \frac{1}{2} = x \end{array}$
-----------------------------------------------------------------------------	--------------------------------------------------------------------------	-------------------------------------------------------------------------------------------------------------------------------------

18 Reduction of Equations to Proportional Terms.

By MULTIPLICATION.

If equal Quantities be multiply'd by equal Quantities, the Products will be equal.

Propose $\frac{x}{a} = b$

$\frac{x}{3d} = e$

$\frac{x}{bb+c} = rr$

Mult. by a . $\frac{ax}{a} = ab$

Mult. by $3d$. $\frac{3dx}{3d} = 3de$

Mult. by $bb+c$. $\frac{bbx+cx}{bb+c} = bbr+err$

That is $x = ab$

That is $x = 3de$

That is $x = bbr+err$

But in Practice only multiply the Denominator of the Fraction by the whole Number on the other side the Equation.

Ex. gr. $\frac{x}{3d} = e$, or $x = 3de$; And so of all others.

By DIVISION.

If equal Quantities be divided by equal Quantities, the Quotes will be equal.

Propose $xx = 6x$

$dx+cx = 99$

$16x-10 = 100$

Div. by x . $\frac{xx}{x} = \frac{6x}{x}$

Div. by $d+c$. $\frac{dx+cx}{d+c} = \frac{99}{d+c}$

That is $16x = 90$

Div. by 16. $\frac{16x}{16} = \frac{90}{16}$

Or $x = 6$

Or $x = \frac{99}{d+c}$

Or $x = \frac{90}{16}$

Abbridg the Operation thus; Take all the Quantities, how many soever, that are multiply'd into the unknown Quantity (here) x , and by them divide the other side of the Equation.

Ex. gr. $dx+cx = 99$. Thus, $x = \frac{99}{d+c}$. And so of all others.

In Simple Equations, the unknown Term x is always clear'd by a contrary Operation: Therefore if it be multiply'd into a Quantity, divide both Parts of the Equation by that Quantity; If it be divided by a Quantity, multiply, &c.

Reduction of Equations to Proportional Terms.

Since if four Quantities are proportional, the Product of the *extrem Terms* is equal to that of the *middle*: From the Reverse hereof 'tis evident, that if an Equation can be so divided into four Parts, that the Product of the *Means* shall be equal to the Products of the *Extremes*, then such Parts are proportional Terms; wherein to make the thing useful, it will be convenient that the last Part (or fourth Term) be the unknown Number.

1. Observe, that if the Equation consist of whole Numbers, let that Quantity which is multiply'd into x , be the first Term.

Ex. $3abx = 99$
Then $3ab.q :: q.x$

If $dx+cx-bx = rrd$
Then $d+c+b \left\{ \frac{rr}{r} \right\} :: \left\{ \frac{d}{rd} \right\} x$

2. Unity

A Resolution of Simple Equations.

19

2. Unity will be one of the Terms, if nothing else can be found.

Ex. $ax + b = r$ That is $ax = r - b$; then $a. 1 :: r - b. x$

In affected Equations $ax + bx = d$. or $ax - d = bx$. then $b. ax - d :: 1. x$

3. In Fractions; If no other way presents it self, reduce them to Integers, and then work as before.

Ex. $\frac{xb}{c} = dd$. $\frac{b}{c} \cdot d :: d \cdot x$. If it had been $\frac{xb}{c} = d$, then

$xb = cd$. Whence again $b \cdot c :: d \cdot x$.

These Methods are of great Use for expressing Algebraic Canons in Proportional Terms, and consequently for turning such Canons into Geometric Effections (if need be); also in finding the Tangents of Curves, and other useful Applications.

The Resolution of Simple Equations.

WHEN a Question is propounded, put x for the unknown Number or Quantity sought, and work with it according to the Terms of the Question as if it were known, till an Equation be made; and then by some (or all) of the preceding Cases in Reduction, x may be clear'd and possess only one Side of the Equation; and thus being equal to something that is known, its Value is also discover'd.

Quest. 1. The Sum of two Numbers is $s (= 19)$ their Difference is $d (= 9)$; What are the Numbers?

1. Put x for the greater Number _____

2. Then the Lesser will be $s - x$ _____

3. Subtract the Lesser from the Greater to find their Difference, which is equal to d . _____

4. Transpose s _____

5. Clear x by Division _____

$$\begin{array}{r} x \\ s - x \\ \hline -s + 2x \\ \hline \text{Or } 2x - s = d \\ \hline 2x = d + s \\ x = \frac{d + s}{2} \end{array}$$

Whence this CANON, *Half the Sum and Difference of any two Numbers, is the greater Number.*

Examen. In Numbers $d = 9$, and $s = 19$ by Position; Then $\frac{9 + 19}{2} = 14 = x$

Therefore also the lesser Number is $19 - 14$, or 5 .

But it's evident that 14 and 5 do satisfy the Question, for their Sum is 19 , and their Difference is 9 .

Quest. 2. The Product of two Numbers is $p (= 100)$ their Difference is the greater Number lessen'd by 2 . What are the Numbers?

20 *The Revolution of Simple Equations.*

The greater _____ x
 The lesser _____ $\frac{p}{x}$
 Their Difference is _____ $x - \frac{p}{x}$ or $\frac{xx - p}{x}$
 The Equation _____ $\frac{xx - p}{x} = x - 2$
 Which reduc'd to Integers, is _____ $xx - p = xx - 2x$
 From each part subtract xx _____ $-p = -2x$
 Change the Signs, (the Equality will }
 yet remain) and clear x by Division - } $x = \frac{p}{2} = 50$

Then the lesser will be p divided by $\frac{p}{2}$, *via* 2.

The Numbers are 50 and 2, whose Product is 100, and whose Difference is $50 - 2$, or 48.

Quest. 3. The Ratio of two Numbers is r to s , (3 to 2) their Difference is d (8). What are the Numbers.

The first Number _____ x
 The second. ($r.s :: x. \frac{sx}{r}$) _____ $\frac{sx}{r}$
 Their Difference is $x - \frac{sx}{r}$ or _____ $\frac{rx - sx}{r}$
 The Equation _____ $\frac{rx - sx}{r} = d$
 Multiply each Part by r _____ $rx - sx = rd$
 Divide each part by $r - s$ _____ $x = \frac{rd}{r - s}$

In Numbers $x = \frac{24}{3-2} = 24$ the first Number.

For the second, $3. 2 :: 24. (\frac{48}{3}) 16$; the second Number: Which two will satisfy the Question.

A Collection of Questions for Exercising the preceding Rules.

Q. 4. A Son asks his Father how old he was? Who answered, If from my Years thou takest 5, and dividest the Remainder by 8, the Quote will be $\frac{1}{3}$ of thy Years. But if to thy Years thou add 72, and multiply the Sum by 3, taking 7 from the Product, the Remainder is the Sum of my Years. How old was Father and Son?

Q. 5. Two Footmen travel, the first goes only six Miles every day, the other goes 10, but sets not out till eight Days after the first. In how many Days will the last overtake the first?

Q. 6. From *Norimberg* to *Rome* are 140 Miles. Two Travellers set out at the same Time from these two Cities, one travelling eight Miles every Day, the other Six; How long will they be before they meet; and how many Miles shall each have travelled?

Q. 7. A Captain sends forth $\frac{1}{3}$ of his Souldiers $+ 10$, and there remains with him $\frac{1}{4} + 15$; How many Souldiers has he in all?

Q. 8. To find the Side of a Square, whose *Area* shall be to the Sum of the Sides in a given Reason. Suppose r to s , (45 to 12 .)

Q. 9. To find the Side of a Cube, whose Surface shall be to its Solidity in a given Reason. Suppose r to s , (6 to 12 .)

Q. 10. A certain Vintner has two sorts of Wines, *A* and *B*: An equal Mixture of both is worth 15 *d.* a Bottle: But if they be so mix'd that three times the Quantity

Of Questions by Diverse Positions.

Quantity of *A* be taken for two times the Quantity of *B*, the mixture will be worth 14 *d.* a Bottle.

Of Questions by Diverse Positions.

WHere Questions are answered by diverse Positions, so many unknown Quantities must be us'd as the Nature and Variety of the Question calls for. But before the Question can be resolv'd, all the unknown Terms must be destroy'd except one; Thus, Equate some one of the unknown Quantities to all the rest by Transposition; then instead of that Quantity, substitute what's equal to it in the following Equation, whereby it will vanish, and so destroy one by one, till only one remains. *Ex. gr.*

Quest. 1. To divide *A* into three parts *x, y, z*; So that
$$\left\{ \begin{array}{l} 1. x + y = a \\ 2. y + z = b \\ 3. z + x = c \end{array} \right.$$

Solution, 1. $x + y = a$. Whence $y = a - x$
 By Subtract. 2. $a - x + z = b$. Whence $z = b - a + x$
 3. $b - a + 2x = c$. Whence $x = \frac{c + a - b}{2}$ Sought.

Again, 1. $\frac{c + a - b}{2} + y = a$ Whence $y = \frac{a + b - c}{2}$ Sought.
 2. $\frac{a + b - c}{2} + z = b$. Whence $z = \frac{b + c - a}{2}$ Sought.

Otherwise (and sometimes more commodiously) the unknown Terms may be destroy'd by Addition or Subtraction. Let the same Question be repeated.

$\left. \begin{array}{l} 1. x + y = a \\ 2. y + z = b \\ 3. z + x = c \end{array} \right\}$	Sub.	$\left. \begin{array}{l} 1. x + y = a \\ 2. y + z = b \\ \hline x - z = a - b \end{array} \right\}$	<i>x</i> being found, the other are easily found as before.
	Add	$\left. \begin{array}{l} 3. z + x = c \\ \hline 2x = a + c - b \end{array} \right\}$	
		$\text{Or, } x = \frac{a + c - b}{2} \text{ Sought.}$	

Multiplication or Division may help sometimes to destroy the unknown Terms, but very rarely.

There's yet another Method frequently made use of by Mr. *Oughtred*, in his *Opuscula Mathematica*, viz. putting one unknown Quantity for the Sum of all, which when discover'd, the parts are readily found out. Let the same Question be still propos'd.

$\left. \begin{array}{l} 1. x + y = a \\ 2. y + z = b \\ 3. z + x = c \end{array} \right\}$	& $U = x + y + z$	$\left\{ \begin{array}{l} z = U - a \\ x = U - b \\ y = U - c \\ \hline U = 3U - a - b - c \end{array} \right.$
---------------------------------------------------------------------------------------------	-------------------	-----------------------------------------------------------------------------------------------------------------

And after Reduction $2U = a + b + c$. Or $U = \frac{a + b + c}{2}$ Sought.

Some of these Methods will never fail in all Cases that can happen in Questions of this Nature. I shall only add three or four for further Exercise.

Of Indetermin'd Questions.

Q. 2. The Husband, Son and Wife, make 96 Years: Those of the Husband with his Son's are equal to the Wife's + 15. Those of the Wife with the Son's, make the Husband's + 2. The Age of each is demanded?

Q. 3. To find three Numbers; So that the first with $\frac{1}{2}$ of the Remainder, the second with $\frac{1}{3}$ of the Remainder; the third with $\frac{1}{4}$ of the Remainder, shall always make 34.

Q. 4. To find four Numbers, a, x, y, z . So that $a+x+y=z+b$. $x+y+z = a+c$. $y+z+x=d$.

Q. 5. To find three Numbers, x, y, z . So that $\frac{1}{2}x + \frac{1}{3}y = \frac{1}{4}y + \frac{1}{5}z = \frac{1}{6}z + \frac{1}{7}x$.
 Note. In this and the like Questions, it will much shorten the Work and ease the Difficulty, to resolve all the Numbers into x , according to the Tenour of the Question, and there will arise $x, \frac{1}{2}x = y$. and $\frac{1}{3}x = z$: Then take any Number for x , which may be divided by the Denominators of the Numbers resolved in to x , viz. 6 and 3, and the Business is done. Let x be 6, then is y 5, and z 4.

Q. 6. To find three Numbers x, y, z . So that $x + \frac{1}{2}y + \frac{1}{3}z = y + \frac{1}{4}z + \frac{1}{5}x = z + \frac{1}{6}x + \frac{1}{7}y$.

Q. 7. Two Numbers being given b and c , to find a third x . So that $c + xxb$, $x + bxc$, and $b + cxa$, may decrease by an equal Interval

Of Indetermin'd Questions.

IF a Question does not appear to be indetermin'd at first sight, (which very seldom misses when 'tis such) yet 'tis discoverable by this, if the Equation or Equations can be so transpos'd and varied, that the known Terms may be equated amongst themselves, (considering them as universal Quantities and not particular Numbers) then such Questions are indetermin'd. For instance; Let

1. $z + y = a$. Whence $y = a - z$
 2. $y + x = b$. Whence $y = b - x$
 3. $x + u = c$. Whence $x = c - u$
 4. $u + z = d$. Whence $z = d - u$
- } Then $x = a - b + c - u$.
- & $x = a - b + c - u$.
- & $d = a - b + c$, all known.

But universal Quantities cannot be equal among themselves, unless every Number was equal to every other Number, which is absurd.

2. A Question is also indetermin'd, which, when the Conditions are satisfied, does include two or more unknown Terms in the Equation, $ay = xx$: There may be innumerable Values of y and x , and the Equation yet be true.

3. When there is not a mutual or reciprocal Habitude betwixt the two Terms in a Question, such Question is indetermin'd. For Instance, *There are two Numbers, three times the greater is equal to the triple Square of the less*. If the Question stays here 'tis indetermin'd, but if the second Number does reciprocally affect the first, thus; *And twice the less is equal to half the greater*; or, *and the Sum, Difference, &c. of both is so*; then the Question is determin'd, and admits but of one Answer. There might be other Rules laid done, but none (for any thing I yet see) which are not reducible to one of these Heads.

Diophantus, who by his prodigious Sagacity and Artifices in resolving Questions of this Nature, has deservedly perpetuated his Name, may be our Pattern in some Examples.

8. c. 2. *Dioph.* Q. 1. To divide a given Square aa into two other Squares.

Let one of the sought Squares be xx , (whose Side is x) then the other will be $aa - xx$, whose Side (any Arbitrary Number being taken, as b) let be $bx - a$; the Square of which is $bbxx - 2bxa + aa - xx$; or $bbx - 2ba - x$, or $bbx + x = 2ba$:

Which

Which reduc'd, gives $x = \frac{2ba}{bb+1}$ the Side of one of the Squares sought. Which Squar'd and subducted from the first given Square, leaves the other Square sought. This Resolution is of great use, for upon this depends the Invention of innumerable Sides and Varieties in a Right-angled Triangle.

10. e. 2. Q. 2. To divide $aa+bb$ into two other Squares, Let $a-c=b$. Assuming two Numbers at pleasure, $c=d$. Let the side of the first Square be $ax-a$, and the side of the other $cx-b$; then proceed as in the last.

11. e. 2.] Q. 3. To find two Square Numbers, whose Difference is d .

12. e. 2.] Q. 4. To find a Number, which added to b and to c , shall make two Squares.

15. e. 2.] Q. 5. To divide a into two such Parts, that if aa be added to each, the Sums will be Squares.

21. e. 2.] Q. 6. To find two Numbers x and y , so that $xx+y$, and $yy+x$ shall be Square Numbers.

24. e. 2.] Q. 7. To find two Numbers x, y , so that $xx-x-y$, and $yy-y-x$, shall be Square Numbers.

33. e. 2.] Q. 8. To find three Numbers, x, y, z . So that $xx+y$, and $yy+z$, and $zz+x$ shall be Squares.

1. e. 3. Dioph.] Q. 9. To find three Numbers, x, y, z . So that $x+y+z-xx$, and $x+y+z-yy$, and $x+y+z-zz$, shall be Square Numbers.

9. e. 3.] Q. 10. To find three Numbers, x, y, z . So that both $x-y=y-z$; and yet the Sums of the three Numbers be all Squares.

18. e. 3.] Q. 11. To find three Numbers, x, y, z . So that both $xy+x+y$, and $x+y+z$, and $zx+z+x$ shall be Squares.

19. e. 3.] Q. 12. To find three Numbers, x, y, z . So that $xy-x-y$, and $yz-y-z$, and $zx-z-x$ shall be Squares.

Q. 13. If a Perpendicular be let fall from the opposite Side of a Right-angled Triangle, thereby dividing the whole into two other, similar and like the whole; 'tis demanded to give a Theorem to find innumerable Integers expressive of the Sides.

Q. 14. To find four more Right-angled Triangles in Integers, which shall have the same Hypothenuse.

Questions producing Simple Equations in Geometry.

I shall only put a few of the easiest Questions here that I can light on, yet such as shall be introductive to higher, and exercise some of the most useful Propositions in *Euclid*, that assist us in the forming Equations,

Quest. 1. In a Triangle, ABD, all the Sides are given; the Segments of the Base (made by falling a Perpendicular from A) are sought.

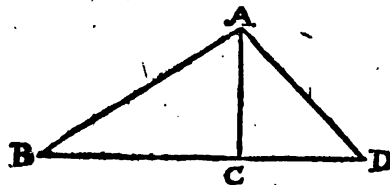

AB = a
BD = b
DA = c

$aa-yy=AC$ Square.
 $cc-bb+2by-yy=AC$ Square. } 47. e. 1. Eucl.
 Wheref. $aa-yy=cc-bb+2by-yy$, or $aa=cc-bb+2by$.

BC = y. CD = b-y Whence $aa+bb-cc=2by$. Then $y = \frac{bb+aa-cc}{2b}$

After the same manner putting CD = x, and BC = b-x, there arises $x = \frac{bb+cc-aa}{2b}$

Quest. 2. In any Obtuse-angled Triangle ABD, the three Sides being given, and either of the lesser BD, produc'd till it meet a Perpend AC, the extream Segment DC is required?

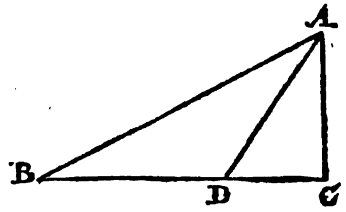

$$\begin{aligned} AB &= a & aa - bb - 2bx - xx &= ACq \\ BD &= b & cc - xx &= ACq \end{aligned} \quad \left. \vphantom{\begin{aligned} AB &= a \\ BD &= b \end{aligned}} \right\} 47. e. 1.$$

DA = c Wheref. $aa - bb - 2bx - xx = cc - xx$, or $aa - bb - 2bx = cc$.

DC = x Whence $aa - cc - bb = 2bx$, then $x = \frac{aa - cc - bb}{2b}$

Quest. 3. In any Triangle ABC, whose Angle at the top is equally bisected, the Sides AB, AC, with one of the Segments DB are given, the other Segment CD is required?

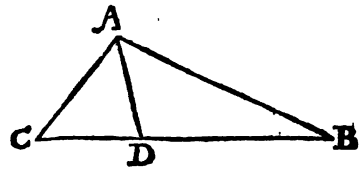

By 3. e. 6. $AB \cdot AC :: DB, CD$, then
 $AB \times CD = AC \times DB$, then by Reduction.
 $\frac{AC \times DB}{AB} = CD$ required.

Quest. 4. Two Triangles ABC, ADC, being given, standing upon the same Basis AC, to find the Segments EC, or BE?

The Angles at B and D are both right, by 31. e. 3. *Eucl.*

The opposite Angle BEA and DEC, are equal, (15. e. 1.)

Therefore the remaining Angles BAE, DCE are equal, (26. e. 1.)

Then the Triangles BEA, DEC, are similar and proportional, (4. e. 6.)

$$\begin{aligned} AB &= a \\ BC &= b \\ CD &= c \\ DA &= d \\ EC &= x \\ BE &= b - x \end{aligned}$$

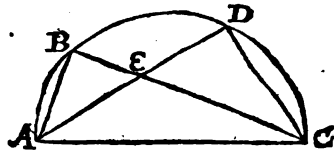

Wherefore $AB \cdot CD :: BE \cdot DE$. and $DC \cdot CE :: AB \cdot AE$.

That is $a \cdot c :: b - x \cdot \frac{cb - cx}{a}$. and $c \cdot x :: a \cdot \frac{ax}{c}$

But $DE + AE = AD$; that is $\frac{cb - cx}{a} + \frac{ax}{c} = d$; which reduced, gives

$$x = \frac{ad - ccb}{aa - cc} = EC \text{ required.}$$

Quest. 5. Let there be a Circle, whose Diameter is AB, and another inscrib'd whose Diameter is AC, touching the first in A : Upon AB from the Center D, erect a Perpendicular ED; cutting the Periphery of the lesser Circle in F, there's given BC the Difference of the Diameters, with the Segment EF; the Diameters are demanded?

FD is a mean Proportional betwixt AD and DC, (13. e. 6.)

AD = x Therefore $AD \times DC = FDq$, that is

EF = a $xx - bx = xx - 2ax + aa$.

FD = x - a

CB = b Which reduc'd, gives $x = \frac{aa}{2a - b} = AD$,

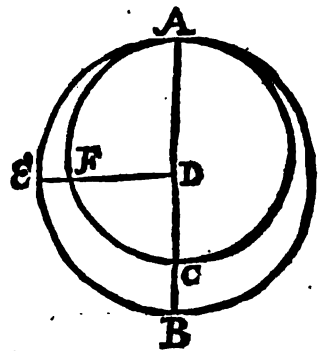

Whose double is the greater Diameter required ; which lessened by b, gives the Lesser.

Of Surd Quantities.

Notation of Surds.

§. 1. **W**HEN the Root of any Quantity can't be truly express'd, (according to any known Notation) such Root is call'd a *Surd, Irrational, or Imperfect Root*, whether of a *Square Cube, &c.* Thus the Square Root of 18 is Imperfect; the next to it in whole Numbers is 4. The usual way of this Notation, is to prefix a Note of Radicality, with the respective Index of the Power. For Instance, The Square Root of 18 is $\sqrt{(2)}18$: or $\sqrt{18}$ the Biquadratic Root thereof is $\sqrt{(4)}18$: Or according to Dr. Wallis and Mr. Newton's way of Notation, the Square Root of 18 is $18^{\frac{1}{2}}$; the Square Root of $aa+bb$ is $aa+bb^{\frac{1}{2}}$; the Cube Root of the Square Root of $aa+bb$ is $aa+bb^{\frac{1}{2}}^{\frac{1}{3}}$, or $aa+bb^{\frac{1}{6}}$. The Biquadratic Root of the Cube of $a+b$, is $a+b^{\frac{1}{3}}^{\frac{1}{4}}$; the Cube Root of $\frac{1}{2}a + \frac{1}{3}b$ is $\frac{1}{2}a + \frac{1}{3}b^{\frac{1}{3}}$; And so of all others, $\frac{1}{2}$ being the Index of Radicality of the fourth Power, $\frac{1}{3}$ that of the fifth Power, &c.

In Fractions the Cubic Root of $\frac{a}{b}$ is $\sqrt{(3)}\frac{a}{b}$ or $\frac{a}{b^{\frac{1}{3}}}$ or $\frac{a^{\frac{1}{3}}}{b^{\frac{1}{3}}}$, which last is the best way, where either the Numerator or Denominator are perfect Powers,

Thus the Cubic Root of $\frac{20}{27}$ is $\frac{20^{\frac{1}{3}}}{27^{\frac{1}{3}}}$, that is $\frac{20^{\frac{1}{3}}}{3}$, or the Cubic Root of 20 divided by 3.

The Cubic Root of $\frac{a^3}{bb}$ is $\frac{a}{bb^{\frac{1}{3}}}$: The Square Root of $\frac{aa-c}{2x+bx+bb}$ is $\frac{\sqrt{aa-c}}{2x+bx+bb^{\frac{1}{2}}}$ &c.

Reduction of Surds to lower Terms when possible.

§. 2. All Surd Quantities may be express'd as above; yet some are reduc'd into lower Terms by this Method. Divide the given Surd by the greatest Square, Cube, Biquadrate, &c. contain'd therein, leaving no Remainder, (according to the Index thereof) and prefix the Root of such Divisor, whether Square, Cube, Biquadrate, &c. before the said Surd, after the Method of Multiplication.

For Instance, $\sqrt{12}$, divided by the greatest Square in it, that leaves no Remainder; viz. 4 gives 3 in the Quote: Hence $\sqrt{12} = 2\sqrt{3}$, (in the lowest terms) for $\sqrt{4} \times \sqrt{3} = \sqrt{12}$, but $\sqrt{4} = 2$; therefore $2\sqrt{3} = \sqrt{12}$. Thus $\sqrt{75} = 5\sqrt{3}$; for $5 = \sqrt{25}$, and $25 \times 3 = 75$. Thus also $\sqrt{(3)40}$, or $40^{\frac{1}{2}} = 2\sqrt{(3)5}$, or $2 \times 5^{\frac{1}{2}}$.

In Species $\sqrt{a^2b} = a\sqrt{b}$. $\sqrt{a^2b - aabb + 2aabc + abcc - ab^3 + b^2cc - 2b^2c + b^3} = a + c - b\sqrt{ab+bb}$. $\sqrt{\frac{48ab}{10}} = 4\sqrt{\frac{3ab}{10}}$. $\sqrt{\frac{aaamm + 4aamm}{ppzc}} = \frac{am}{pz} \times \frac{\sqrt{aa+4a}}{1}$

or $\frac{am}{pz} \times \sqrt{aa+4a}$. This Reduction is of very great use, because the Values of Quantities are more easily discovered in lesser Terms than greater, also in the Approximation of Roots. For Instance, If $d = \sqrt{aabb + aacc}$, then is $d = a\sqrt{bb+cc}$; and dividing each part of the Equation by a , we have $\frac{d}{a} = \sqrt{bb+cc}$, that is according

to the Method of extracting Surd Quantities, $\frac{d}{a} = b + \frac{cc}{2b}$, &c. Whereas if an

immediately extraction had been made without Reduction, we should have had $d = ab + \frac{acc}{ab} - \&c.$ which is more perplex'd and troublesome, especially if continued to another Operation.

For the greater Ease in a reduc'd Notation of *Numeral Surds*, the following Table may properly be here inserted; whose Use is briefly thus. Opposite to $\sqrt{45}$ in the first Column is $3\sqrt{5} = \sqrt{45}$ in the lowest Terms, $\sqrt{288} = 6\sqrt{8}$ reduc'd. $\sqrt{(3)}$ 2560 = $8\sqrt{(3)5}$.

A Table of Irrational Surds, reduc'd to lower Terms.

$\sqrt{6} = 2\sqrt{1.5}$	$\sqrt{75} = 5\sqrt{3}$	$\sqrt{200} = 10\sqrt{5}$	$\sqrt{486} = 9\sqrt{6}$
$\sqrt{8} = 2\sqrt{2}$	$\sqrt{80} = 4\sqrt{5}$	$\sqrt{216} = 6\sqrt{6}$	$\sqrt{490} = 7\sqrt{10}$
$\sqrt{10} = 2\sqrt{2.5}$	$\sqrt{90} = 3\sqrt{10}$	$\sqrt{243} = 9\sqrt{3}$	$\sqrt{500} = 10\sqrt{5}$
$\sqrt{12} = 2\sqrt{3}$	$\sqrt{96} = 4\sqrt{6}$	$\sqrt{245} = 7\sqrt{5}$	$\sqrt{512} = 8\sqrt{8}$
$\sqrt{18} = 3\sqrt{2}$	$\sqrt{98} = 7\sqrt{2}$	$\sqrt{250} = 5\sqrt{10}$	$\sqrt{539} = 7\sqrt{11}$
$\sqrt{20} = 2\sqrt{5}$	$\sqrt{99} = 3\sqrt{11}$	$\sqrt{252} = 6\sqrt{7}$	$\sqrt{467} = 9\sqrt{7}$
$\sqrt{24} = 2\sqrt{6}$	$\sqrt{108} = 6\sqrt{3}$	$\sqrt{275} = 5\sqrt{11}$	$\sqrt{600} = 10\sqrt{6}$
$\sqrt{27} = 3\sqrt{3}$	$\sqrt{112} = 4\sqrt{7}$	$\sqrt{288} = 6\sqrt{8}$	$\sqrt{640} = 8\sqrt{10}$
$\sqrt{28} = 2\sqrt{7}$	$\sqrt{125} = 5\sqrt{5}$	$\sqrt{294} = 7\sqrt{6}$	$\sqrt{648} = 9\sqrt{8}$
$\sqrt{32} = 4\sqrt{2}$	$\sqrt{128} = 8\sqrt{2}$	$\sqrt{300} = 10\sqrt{3}$	$\sqrt{700} = 10\sqrt{7}$
$\sqrt{40} = 2\sqrt{10}$	$\sqrt{147} = 7\sqrt{3}$	$\sqrt{320} = 8\sqrt{5}$	$\sqrt{704} = 8\sqrt{11}$
$\sqrt{44} = 2\sqrt{11}$	$\sqrt{150} = 5\sqrt{6}$	$\sqrt{343} = 7\sqrt{7}$	$\sqrt{808} = 10\sqrt{8}$
$\sqrt{45} = 3\sqrt{5}$	$\sqrt{160} = 4\sqrt{10}$	$\sqrt{360} = 6\sqrt{10}$	$\sqrt{810} = 9\sqrt{10}$
$\sqrt{48} = 4\sqrt{3}$	$\sqrt{162} = 9\sqrt{2}$	$\sqrt{384} = 8\sqrt{6}$	$\sqrt{891} = 9\sqrt{11}$
$\sqrt{50} = 5\sqrt{2}$	$\sqrt{175} = 5\sqrt{7}$	$\sqrt{392} = 7\sqrt{8}$	$\sqrt{1000} = 10\sqrt{10}$
$\sqrt{54} = 3\sqrt{6}$	$\sqrt{176} = 4\sqrt{11}$	$\sqrt{396} = 6\sqrt{11}$	$\sqrt{1100} = 10\sqrt{11}$
$\sqrt{63} = 3\sqrt{7}$	$\sqrt{180} = 6\sqrt{5}$	$\sqrt{405} = 9\sqrt{5}$	$\sqrt{1200} = 10\sqrt{12}$
$\sqrt{72} = 3\sqrt{8}$	$\sqrt{192} = 8\sqrt{3}$	$\sqrt{448} = 8\sqrt{7}$	
$2\sqrt{2} = \sqrt{8}$	$2\sqrt{5} = \sqrt{20}$	$2\sqrt{7} = \sqrt{28}$	$2\sqrt{10} = \sqrt{50}$
$3\sqrt{2} = \sqrt{18}$	$3\sqrt{5} = \sqrt{45}$	$3\sqrt{7} = \sqrt{63}$	$3\sqrt{10} = \sqrt{90}$
$4\sqrt{2} = \sqrt{32}$	$4\sqrt{5} = \sqrt{80}$	$4\sqrt{7} = \sqrt{112}$	$5\sqrt{10} = \sqrt{160}$
$5\sqrt{2} = \sqrt{50}$	$5\sqrt{5} = \sqrt{125}$	$5\sqrt{7} = \sqrt{175}$	$5\sqrt{10} = \sqrt{250}$
$6\sqrt{2} = \sqrt{72}$	$6\sqrt{5} = \sqrt{180}$	$6\sqrt{7} = \sqrt{252}$	$6\sqrt{10} = \sqrt{360}$
$7\sqrt{2} = \sqrt{98}$	$7\sqrt{5} = \sqrt{245}$	$7\sqrt{7} = \sqrt{343}$	$7\sqrt{10} = \sqrt{490}$
$8\sqrt{2} = \sqrt{128}$	$8\sqrt{5} = \sqrt{320}$	$8\sqrt{7} = \sqrt{448}$	$8\sqrt{10} = \sqrt{640}$
$9\sqrt{2} = \sqrt{162}$	$9\sqrt{5} = \sqrt{405}$	$9\sqrt{7} = \sqrt{567}$	$9\sqrt{10} = \sqrt{810}$
$10\sqrt{2} = \sqrt{200}$	$10\sqrt{5} = \sqrt{500}$	$10\sqrt{7} = \sqrt{700}$	$10\sqrt{10} = \sqrt{1000}$
$2\sqrt{3} = \sqrt{12}$	$2\sqrt{6} = \sqrt{24}$	$2\sqrt{8} = \sqrt{32}$	$2\sqrt{11} = \sqrt{44}$
$3\sqrt{3} = \sqrt{27}$	$3\sqrt{6} = \sqrt{54}$	$3\sqrt{8} = \sqrt{72}$	$3\sqrt{11} = \sqrt{99}$
$4\sqrt{3} = \sqrt{48}$	$4\sqrt{6} = \sqrt{96}$	$4\sqrt{8} = \sqrt{128}$	$4\sqrt{11} = \sqrt{176}$
$5\sqrt{3} = \sqrt{75}$	$5\sqrt{6} = \sqrt{150}$	$5\sqrt{8} = \sqrt{200}$	$5\sqrt{11} = \sqrt{275}$
$6\sqrt{3} = \sqrt{108}$	$6\sqrt{6} = \sqrt{216}$	$6\sqrt{8} = \sqrt{288}$	$6\sqrt{11} = \sqrt{396}$
$7\sqrt{3} = \sqrt{147}$	$7\sqrt{6} = \sqrt{294}$	$7\sqrt{8} = \sqrt{392}$	$7\sqrt{11} = \sqrt{539}$
$8\sqrt{3} = \sqrt{192}$	$8\sqrt{6} = \sqrt{384}$	$8\sqrt{8} = \sqrt{512}$	$8\sqrt{11} = \sqrt{704}$
$9\sqrt{3} = \sqrt{243}$	$9\sqrt{6} = \sqrt{486}$	$9\sqrt{8} = \sqrt{648}$	$9\sqrt{11} = \sqrt{891}$
$10\sqrt{3} = \sqrt{300}$	$10\sqrt{6} = \sqrt{600}$	$10\sqrt{8} = \sqrt{800}$	$10\sqrt{11} = \sqrt{1100}$
$2\sqrt{(3)2} = \sqrt{(3)16}$	$2\sqrt{(3)3} = \sqrt{(3)24}$	$2\sqrt{(3)4} = \sqrt{(3)32}$	$2\sqrt{(3)5} = \sqrt{(3)40}$
$3\sqrt{(3)2} = 54$	$3\sqrt{(3)3} = 81$	$3\sqrt{(3)4} = 108$	$3\sqrt{(3)5} = 135$
$4\sqrt{(3)2} = 128$	$4\sqrt{(3)3} = 192$	$4\sqrt{(3)4} = 256$	$4\sqrt{(3)5} = 320$
$5\sqrt{(3)2} = 250$	$5\sqrt{(3)3} = 375$	$5\sqrt{(3)4} = 500$	$5\sqrt{(3)5} = 625$
$6\sqrt{(3)2} = 432$	$6\sqrt{(3)3} = 648$	$6\sqrt{(3)4} = 864$	$6\sqrt{(3)5} = 1080$
$7\sqrt{(3)2} = 686$	$7\sqrt{(3)3} = 1029$	$7\sqrt{(3)4} = 1372$	$7\sqrt{(3)5} = 1715$
$8\sqrt{(3)2} = 1024$	$8\sqrt{(3)3} = 1536$	$8\sqrt{(3)4} = 2048$	$8\sqrt{(3)5} = 2560$
$9\sqrt{(3)2} = 1458$	$9\sqrt{(3)3} = 2187$	$9\sqrt{(3)4} = 2916$	$9\sqrt{(3)5} = 3645$
$10\sqrt{(3)2} = 2000$	$10\sqrt{(3)3} = 3000$	$10\sqrt{(3)4} = 4000$	$10\sqrt{(3)5} = 5000$

Multiplication of like Surd Roots.

§. 3. The Reverse of the preceding Method of reducing Integral Surds to lower Terms, furnishes us with a Method of multiplying them. For Instance, $\sqrt{36} = 6\sqrt{1} = 6$, and $\sqrt{aa+2ab+bb} = a+b\sqrt{1} = a+b$, also $\sqrt{aa+baa} = a\sqrt{1+b}$, as is evident from the preceding Section; then it's also evident that the true Product of a into $\sqrt{1+b} = a\sqrt{1+b} = \sqrt{aa+baa}$: And so of all other Homogeneous Roots. Ex. gr.

$$\begin{array}{r} \text{Mult. } \sqrt{10+\sqrt{6}} \\ \text{by } \sqrt{10+\sqrt{6}} \\ \hline \sqrt{100+\sqrt{60}} \\ \sqrt{60+\sqrt{36}} \\ \hline \sqrt{100+2\sqrt{60}+\sqrt{36}} \end{array}$$

Which in $\sqrt{10+\sqrt{6}}$
shorter $\sqrt{10+\sqrt{6}}$
terms is $\frac{10+2\sqrt{60}+6}{16+2\sqrt{60}}$

$$\begin{array}{r} \text{Mult. } 3+\sqrt{2}-\sqrt{3} \\ \text{by } 3+\sqrt{2}+\sqrt{3} \\ \hline 9+3\sqrt{2}-3\sqrt{3} \\ 3\sqrt{2}+2-\sqrt{6} \\ +3\sqrt{3}+\sqrt{6}-\sqrt{9} \\ \hline \end{array}$$

$$\begin{array}{r} \text{Mult. } \sqrt{ab+\frac{d}{gg}}; +\sqrt{\frac{d}{2}} \\ \text{by } dd-\sqrt{\frac{2}{a}} \end{array}$$

$$\begin{array}{r} \text{Prod. } 9+6\sqrt{2}+2-3 \\ \text{that is } 8+6\sqrt{2}. \end{array}$$

$$\text{Product, } \frac{dd\sqrt{ab}+dd\sqrt{\frac{d}{gg}}}{gg} + \frac{dd\sqrt{\frac{d}{2}}}{2} - \sqrt{2b} - \sqrt{\frac{2d}{gg}} - \sqrt{\frac{d}{a}}$$

Division of like Surd Roots.

§. 4. The preceding Method of reducing Fractional Surds, (§.2.) leads us to a Division of them. For Instance, $\frac{\sqrt{dg+ss}}{16} = \frac{1}{4} \sqrt{\frac{dg+ss}{16}} = \frac{1}{4} \sqrt{dg+ss}$

Therefore $\frac{1}{4}$ of $\sqrt{dg+ss}$, or $\sqrt{dg+ss}$ divided by 4, returns to what it was, viz $\frac{\sqrt{dg+ss}}{16}$, or the Square Root of the Numerator divided by the Square Root of the Denominator.

$$\begin{array}{r} \text{Thus } \sqrt{4-2d} \sqrt{4d+4gg+2dd-2dgg} \sqrt{d+gg} \\ \hline \sqrt{4d-2dd} \end{array}$$

$$\begin{array}{r} \text{Also } \sqrt{dd+g} \sqrt{2dd+dd\sqrt{dd}-\sqrt{3add}+g\sqrt{2}+gdd-g\sqrt{3a}} \sqrt{2A+dd-\sqrt{3a}} \\ \hline \sqrt{2dd} \end{array}$$

$$\begin{array}{r} \sqrt{\frac{1}{2}d} \sqrt{\frac{3dd\sqrt{\frac{1}{2}d}}{3dd\sqrt{\frac{1}{2}d}} - \sqrt{\frac{1}{2}d} \frac{a}{d} - \frac{a}{b} - \sqrt{\frac{1}{2}d} \frac{a}{d} - \frac{a}{b} - \sqrt{\frac{1}{2}d} \frac{a}{d} - \frac{a}{b}} \\ \hline -\sqrt{\frac{1}{2}d} \frac{a}{d} - \frac{a}{b} \\ -\sqrt{\frac{1}{2}d} \frac{a}{d} - \frac{a}{b} \\ \hline -\sqrt{\frac{1}{2}d} \\ -\sqrt{\frac{1}{2}d} + e \text{ or } \sqrt{\frac{ee}{2d}} \text{ Remainder.} \end{array}$$

To show the Necessity and great Use of the third and fourth preceding Sections; the former for freeing Equations from Surds, the latter for finding out the several Values of Roots in *Analysis Expressions*, &c. I shall give an Example or two, without proceeding to other Operations in Surds, my Design here being not to enlarge upon any Head, further than 'tis useful in Algebraic Practice, presuming this sufficient for that End; and such as would know more of *Surds*, may peruse *Dr. Wallis's Treatise of Algebra*, cap. 25. who has writ the best on this Subject.

1. Suppose the three Sides of a Triangle a, b, c were given give me, and the Diameter of a Circle x , in which the said Triangle may be inscrib'd, is demanded?

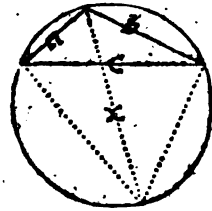

Since in any Quadrilateral inscrib'd in a Circle, the two Rectangles of the opposite Sides are equal to the Rectangle of the Diagonals.

I have this Equation, $b\sqrt{xx-aa} + a\sqrt{xx-bb} = xc$.

By Transposition, $b\sqrt{xx-aa} = xc - a\sqrt{xx-bb}$

Each part squar'd, $bbxx - bbaa = xxc - 2caa\sqrt{xx-bb} + aaxx - aabb$

Equally expung'd, . . . $xbb = xcc - 2ca\sqrt{xx-bb} + aax$

Transpos'd, $2ca\sqrt{xx-bb} = xcc + aax - bbx$

Equally divided, $\sqrt{xx-bb} = \frac{xcc + aax - bbx}{2ca}$

$$\sqrt{xx-bb} = \frac{xcc + aax - bbx}{2ca}$$

Each part squar'd, $xx - bb = \frac{x^2c^2 + 2x^2ac - 2x^2c^2b^2 + a^2x^2 - 2x^2a^2b^2 + b^2x^2}{4c^2a^2}$

The Fraction clear'd, $4ccaaxx - 4c^2a^2b^2 = x^2c^2 + 2x^2ac^2 - 2x^2c^2b^2 + a^2x^2 - 2x^2a^2b^2 + b^2x^2$

By Transposition to make highest known Power positive. $4ccaaxx - x^2c^2 - 2x^2ac^2 + 2x^2c^2b^2 - a^2x^2 + 2x^2a^2b^2 - b^2x^2 = 4c^2a^2b^2$

By common Reduction. $xx = \frac{4ccaabb}{2cca^2 + 2c^2bb + 2a^2b^2 - c^2 - a^2 - b^2}$

Lastly, If the Square Root of each part be extracted, we have the Diameter of the Circle required, viz.

$$x = \sqrt{\frac{4ccaabb}{2cca^2 + 2c^2bb + 2a^2b^2 - c^2 - a^2 - b^2}}$$

Or in lower Terms, $x = \frac{2cab\sqrt{4ccaabb}}{2c^2a^2 + 2c^2b^2 + 2a^2b^2 - c^2 - a^2 - b^2}$

2. Suppose in this Equation $xx + bx = d$, one of the Values of x were given me, viz. $x = \sqrt{d + \frac{bb}{4}} - \frac{b}{2}$, and I am to find the other, (all Quadratics having two Roots, as will be shewed hereafter)

Then

$$\text{Then } x = \sqrt{d + \frac{bb}{4}} + \frac{b}{2} \quad \left(\begin{array}{l} xx + bx - d \\ xx - x\sqrt{d + \frac{bb}{4}} + \frac{xb}{2} \end{array} \right) \left(\begin{array}{l} x + \sqrt{d + \frac{bb}{4}} + \frac{b}{2} \\ x - \sqrt{d + \frac{bb}{4}} + \frac{b}{2} \end{array} \right)$$

Whence also $x = -\sqrt{d + \frac{bb}{4}} - \frac{b}{2}$.

The same may also be done in Cubics.

$$x\sqrt{d + \frac{bb}{4}} + \frac{xb}{2} - d$$

$$x\sqrt{d + \frac{bb}{4}} - d - \frac{bb}{4} + \frac{b}{2}\sqrt{d + \frac{bb}{4}}$$

$$\frac{xb}{2} + \frac{bb}{4} - \frac{b}{2}\sqrt{d + \frac{bb}{4}}$$

$$\frac{xb}{2} + \frac{bb}{4} - \frac{b}{2}\sqrt{d + \frac{bb}{4}}$$

Of Quadratic Equations.

S. 1. **W**hatever may be resolv'd into Parts, was first compounded of Parts, as xx (supposing x an Universal Quantity) was first made by the Multiplication of x into its Self. Thus also xxx , was xx before it could arise to be xxx ; and so on *ad infinitum*. Whence it follows, that in any Equation whatever, there are so many Compositions or Values of x , as is the Index of the highest Power. For Instance, $xx + bx = d$; x here has two Values. Again, in $xxx + bx = d$, there are three Values of x ; and so in higher Equations.

S. 2. But from hence it does not follow that these Values are always Positive, for sometimes they are Negative, sometimes mix'd; sometimes only Imaginary, or such as include an impossibility in Nature, as will appear hereafter from their first Composition; and sometimes one or two, or more of them may be the same, yet there will be always so many and no more, as is the Index of the higher Power: But how to determine how many there are, which Positive, which Negative, and which Imaginary in any Equation whatever, is best shew'd by their Origination.

S. 3. Let x (as before) be an Universal Quantity, capable of expressing the Value of any effable or ineffable Number; and let the following Equations be made from the Alternation and Values of x .

$$1. \quad \begin{array}{l} x = b \dots x - b = 0 \\ x = c \dots x - c = 0 \\ \hline \begin{array}{l} xx - bx \\ - cx + bc \end{array} \} = 0 \end{array}$$

An Equat. of the third Form. $\left. \begin{array}{l} xx - b \\ - c \end{array} \right\} x = -bc$

$$2. \quad \begin{array}{l} x = -b \quad x + b = 0 \\ x = +c \quad x - c = 0 \\ \hline \begin{array}{l} xx + bx \\ - cx - bc \end{array} \} = 0 \end{array}$$

An Equat. of the 1st or 2^d Form. $\left. \begin{array}{l} xx + b \\ - c \end{array} \right\} x = bc$

$$3. \quad \begin{array}{l} x = -b \quad x + b = 0 \\ x = -c \quad x + c = 0 \\ \hline \begin{array}{l} xx + bx \\ + cx + bc \end{array} \} = 0 \end{array}$$

An Imaginary Equation. $\left. \begin{array}{l} xx + b \\ c \end{array} \right\} x = -bc$

1. Whence we may observe, that an Equation of the third Form (supposing $\frac{-b}{-c}$ made one Quantity, as also bc) has always two positive Roots or Values of x .

2. An Equation of the first or second Form, has always two Roots: Let $\frac{+b}{-c}$ be made one Quantity; and if $+b$ prevails, or if the Equation be of the first Form, the greater Root is Negative, and the lesser Positive. If the Equation be of the second Form, (or if $-c$ prevails) the greater Root is Positive, and the lesser Negative; and if both the Roots be equal, the second Root will be destroyed.

Of Quadratic Equations.

The three Forms being put in their most Simple Terms, appear thus with their different Roots.

Third Form, $xx - bx = -d$	}	$x = \frac{\sqrt{bb} - d + \frac{b}{c}}{4}$ $x = \frac{\frac{b}{2} - \sqrt{\frac{bb}{4} - d}}{4}$	Greater Root Positive. Lesser Root Positive.
First Form, $xx + bx = d$	}	$x = -\frac{b}{4} - \sqrt{d + \frac{bb}{4}}$ $x = \sqrt{d + \frac{bb}{4}} - \frac{b}{4}$	Greater Root Negative. Lesser Root Positive.
Second Form, $xx - bx = d$	}	$x = \sqrt{d + \frac{bb}{4}} + \frac{b}{2}$ $x = \frac{1}{2}b - \sqrt{d + \frac{bb}{4}}$	Greater Root Positive. Lesser Root Negative.

3. The third and last Multiplication of the two Negative Values of x , exhibit an *imaginary or impossible Equation*; for two Positive Quantities can't be equal to a Negative one: Therefore I shall pass over the Roots as expres'd in the other three preceding Forms, because useless.

4. The Coefficient of (or Quantity affecting) the second Term, in the first and second Form, is the Difference of the two Roots, (under a contrary Sign) according as the Negative or Positive prevails; and in the third Form is the Sum of the two Roots under a contrary Sign.

5. The *Homogeneous Comparation*, as *Vieta* calls it, or *absolute known Quantity* that possesses one Side of the Equation, is equal to a Rectangle of the two Roots, both multiply'd under the same Sign in every Form.

6. In the third Form the Coefficient is always greater than any of the two Roots: And if a Quarter of the Square of the whole Coefficient be equal to the *absolute known Number*, the two Roots are both of the same Value, or else not.

6. If in the first and second Form, the two Roots are of the same Value, the second Term will be destroyed.

7. Lastly, Supposing the whole Equation made equal to 0, so often as + follows -; or the contrary, so many Affirmative Roots there in that Equation: and so often as + follows +, and - follows -, so many are the Negative Roots, or at least *real Ones*, for the Imaginary I pass over as useless.

§. 4. We are first to *order and prepare an Equation*, before we extract the Roots thereof, the Method may be fully and briefly compris'd under these Rules.

1. If the highest unknown Power be Negative, change all the Signs, (the Equation is not destroy'd) because 'tis impossible for a Negative Square to have any Root, since $+x +$ gives $+$, and $-x +$ gives $+$. For Instance, If $bx - xx = d$, then is $-bx + xx = -d$.

2. If the highest unknown Power be not first in Order, make it so, because the Extraction must begin therewith; thus $-bx + xx = -d$, becomes $xx - bx = -d$.

3. If the highest unknown Power be affected with any Coefficient, it must be clear'd either by Division or Multiplication.

For Instance, If $cx + bx = d$, then $xx + \frac{b}{c}x = \frac{d}{c}$. If $\frac{xx}{16} + bx = d$, then $xx + 16bx = 16d$.

4. If there be no Coefficient to the second Term, Unity supplies the place. Ex. gr. $xx + x = d$, then is $xx + 1x = d$.

5. If there be more Coefficients to the second Term than one, they must be all reduc'd to one.

For Example, If $xx + bx + cx = \frac{d}{r}$, then $xx + \frac{b+c}{r}x = \frac{d}{r}$.

§. 5. When

§. 5. When an Equation is prepar'd and ordered as above, the Roots of them (which I have already set down, with their respective Forms, for a greater convenience of comparing them with their Original Formations) may be extracted by several Methods; One of which may be this.

Put y (an unknown Quantity $+$ or $-$, the Coefficient of the second Term, (taking always a contrary Sign) divided by the Index of the highest unknown Power, as 2 in the Square, 3 in the Cube, 4 in the Biquadrate, &c. And by this Artifice the second Term will be destroy'd, if a new Equation be made answerable to the respective Parts of the first. For Instance,

1. Let $xx + bx = d$, and let $y = \frac{1}{2}b = x$.
2. Then $yy - yb + \frac{1}{4}bb = \{xx\} = d$
3. Also . . . $yy - \frac{1}{4}bb = \{bx\} = d$
4. Where $yy - \frac{1}{4}bb = d$.
5. By Transp. $yy = d + \frac{1}{4}bb$.
6. By equal Extract. $y = \sqrt{d + \frac{1}{4}bb}$
- * 7. But $x + \frac{1}{2}b (= y) = \sqrt{d + \frac{1}{4}bb}$ * If $y = \frac{1}{2}b = x$
Then $y - x = \frac{1}{2}b$
8. Then also $x = \sqrt{d + \frac{1}{4}bb} - \frac{1}{2}bb$

Reassuming the seventh Step, where $x + \frac{1}{2}b = \sqrt{d + \frac{1}{4}bb}$. Square each part of the Equation, there arises $xx - xb + \frac{1}{4}bb = d + \frac{1}{4}bb$. Whence we have also another Method for resolving Quadratic Equations, by adding $\frac{1}{4}$ of the Square of the whole Coefficient to both Sides of the Equation, thereby making the first Part a true Square, and consequently capable of an exact Extraction. Thus also in an Equation of the second

Form, $xx + \frac{bx}{c} = d$, by adding to each side $\frac{bb}{4cc}$ ($\frac{1}{4}$ of the Square of $\frac{b}{c}$) there arises $xx + \frac{b}{c}x + \frac{bb}{4cc} = d + \frac{bb}{4cc}$, and by extracting the Roots of both Sides, $x + \frac{b}{2c} = \sqrt{d + \frac{bb}{4cc}}$, and by transposing of $\frac{b}{2c}$, $x = \sqrt{d + \frac{bb}{4cc}} - \frac{b}{2c}$. And lastly,

In the third Form, $xx - b - cxx = d$; then by adding a quarter of the Square of the whole Coefficient to each Side of the Equation, we have $xx - b - cxx + \frac{bb + 2cb + cc}{4} = d + \frac{bb + 2cb + cc}{4}$. And by equal Extraction of Roots, $x - \frac{b+c}{2} = \sqrt{\frac{bb + 2cb + cc}{4} - d}$, and by Transposition $x = \sqrt{\frac{bb + 2cb + cc}{4} - d} + \frac{b+c}{2}$.

§. 6. Having discovered one of the Roots of any one of the three Forms, the other may be found by Division, as was shewed before in the Division of Surds. Let it be proposed to find the second Root in the third Form, the first being given in the Equation, $xx - bx = -d$, viz. $\sqrt{\frac{bd}{4}} - d + \frac{b}{2}$; Then also

by Transposition $x + \sqrt{\frac{bd}{4}} - d - \frac{b}{2} = 0$; Also $xx - bx + d = 0$, and this divided by

that, exhibits the following Operation, the Quote of which is equal to Nothing; for if 0 divides 0, 0 will result. Thus by Transposition, the second Root is found,

$$x = \frac{b}{2} - \sqrt{\frac{bb}{4} - d}. \text{ Which is also Po-}$$

sitive, and 'tis the third Form only that has two Positive Robts, and which are so ambiguous in many Algebraic Operations, that till we have tried both, 'tis difficult to know which is the most proper Solution of a Question, but in the other two Forms this Difficulty never occurs, but the enquired Root comes first.

$$\begin{aligned} & x - \sqrt{\frac{bd}{4}} - d - \frac{b}{2} = 0 \\ & \frac{xx - bx + d}{x - \sqrt{\frac{bd}{4}} - d - \frac{b}{2}} = \frac{0}{0} \\ & \frac{xx - bx + d}{x - \sqrt{\frac{bd}{4}} - d - \frac{b}{2}} = \frac{xx - bx + d}{x - \sqrt{\frac{bd}{4}} - d - \frac{b}{2}} \\ & \frac{xx - bx + d}{x - \sqrt{\frac{bd}{4}} - d - \frac{b}{2}} = \frac{xx - bx + d}{x - \sqrt{\frac{bd}{4}} - d - \frac{b}{2}} \\ & \frac{xx - bx + d}{x - \sqrt{\frac{bd}{4}} - d - \frac{b}{2}} = \frac{xx - bx + d}{x - \sqrt{\frac{bd}{4}} - d - \frac{b}{2}} \\ & \frac{xx - bx + d}{x - \sqrt{\frac{bd}{4}} - d - \frac{b}{2}} = \frac{xx - bx + d}{x - \sqrt{\frac{bd}{4}} - d - \frac{b}{2}} \end{aligned}$$

There's yet another way of finding the two Roots at once.

Let the Sum of the two Roots be $2p$, and their Difference $2q$, then is the greater Root $p+q$, and the lesser $p-q$; then also is $x-p-q=0$, and $x-p+q=0$. Multiply for a new Equation.

$$\begin{array}{r} x-p-q \\ x-p+q \\ \hline xx-xp-xq \\ \quad -xp+pp+pq \\ \quad \quad -qx-pq-qq \\ \hline xx-2px+pp-qq=0 \\ xx+bx-dd = 0 \end{array}$$

Compare the Product with any of the three Forms. Suppose with the first, xx and xx destroy each other, and there are yet these two Equations of the Parts $-2px=bx$, and $pp-qq=-d$.

The first Equation is reduced to $-2p=b$; divide each part by 2. $-p=\frac{1}{2}b$.

Wherefore also $pp=\frac{bb}{4}$. Which substitute in the Room of pp in the second Equation, and there arises $\frac{bb}{4}-qq=-d$; or by Transposition $\frac{bb}{4}+d=+qq$; and

by equal Extraction $\sqrt{\frac{bb}{4}+d}=+q$; therefore the two Roots will be found at once,

viz. the greater $p+q=-\frac{1}{2}b+\sqrt{\frac{bb}{4}+d}$, the lesser $p-q=-\frac{1}{2}b-\sqrt{\frac{bb}{4}+d}$. The same Method may be pursued in the other two Cases.

§. 7. There are yet Biquadratics, as also higher Equations belonging to the three preceding Forms, which are of the same Nature as Quadratics, and may not improperly receive their Solution here.

The first Form $xxxx + bxx = d$

The Positive Root $xx = \sqrt{d + \frac{b^2}{4}} - \frac{b}{2}$

A second Extraction $x = \sqrt{d + \frac{bb}{4}} - \frac{b}{2} \Big|^{1/2}$

The second Form $xxxx - bxx = d$

The Positive Root $xx = \sqrt{d + \frac{bb}{4}} + \frac{b}{2}$

A second Extraction $x = \sqrt{d + \frac{bb}{4}} + \frac{b}{2} \Big|^{1/2}$

The third Form $xxxx - bxx = -d$

The greater Positive Root $xx = \sqrt{\frac{bb}{4} - d} + \frac{b}{2}$

A second Extraction $x = \sqrt{\frac{bb}{4} - d} + \frac{bb}{2} \Big|^{1/2}$

These three Forms in Biquadratics occur pretty often; and the same Solution would hold for any higher Power thus qualified.

For

Questions falling under Quadratic Equations. 33

For Instance, $x^3 + bx^2 = d$, the Root of which is $xxx = \sqrt{d + \frac{bb}{4}} - \frac{b}{2}$, and

by extracting the Cube Root of each, $x = \sqrt[3]{d + \frac{bb}{4}} - \frac{b}{2}$;

Thus also if $x^{10} + bx^{10} = d$, then is $x = \sqrt[10]{d + \frac{bb}{4}} - \frac{b}{2}$. And so of all others thus qualified, *ad infinitum*.

Numerical Questions falling under Quadratic Equations.

Q. 1. **C**LAVIUS in his Treatise of Algebra, (*Cap. 31. Quest. 58.*) puts this Question; Two Persons have each a certain number of Crowns; the Sum of which being subducted from the Sum of the Squares of the said Numbers (made separately) leaves 78; but their Sum being added to the Product of the two Numbers, gives 39. 'Tis demanded how many Crowns each had?

This Question, says *Clavius*, is too difficult to be answer'd by Algebra, without very good knowledg in Geometry. But Algebra is now brought to that Perfection, that Geometry depends rather upon it, than it does upon Geometry, since we are not only able to resolve such Questions by pure Algebra, as no Geometrician can do by Rule and Compass, but also to find out Laws and Rules for several *Geometric Effusions*, which otherwise would be desperate.

But to return from this Digression. Let $2y$ be the Sum of the unknown Numbers, and $2x$ their Difference, and let $78 = a$, and $39 = b$; then $y+x$ the greater Number, and $y-x$ the Lesser. Hence,

- | | |
|---------------------------------------------------------------------|--------------------------------------------------------------------|
| 1. The Sum of their Squares is | $2yy + 2xx$ |
| 2. <i>Idem</i> , lessened by their Sum, | $2yy + 2xx - 2y = a$ |
| 3. Clear xx | $2x = y + \frac{1}{2}a - yy$ |
| 4. Their Product added to their Sum = b | $yy - xx + 2y = b$ |
| 5. Clear xx | $xx = yy + 2y - b$ |
| 6. From the 3 ^d and 5 th Steps | $y + \frac{1}{2}a - yy = yy + 2y - b$ |
| 7. By Reduction | $yy + \frac{1}{2}y = \frac{2b+a}{4}$ |
| 8. Add to each $\frac{1}{4}$ of the Square of the whole Coefficient | $yy + \frac{1}{2}y + \frac{1}{16} = \frac{2b+a}{4} + \frac{1}{16}$ |
| 9. Extract equally | $y + \frac{1}{4} = \sqrt{\frac{2b+a}{4} + \frac{1}{16}}$ |
| 10. Transpose $\frac{1}{4}$ | $y = \sqrt{\frac{2b+a}{4} + \frac{1}{16}} - \frac{1}{4}$ |

Which is in Numbers $\sqrt{\frac{78+78}{4} + \frac{1}{16}} - \frac{1}{4}$ or $\sqrt{39\frac{1}{2}} - \frac{1}{4} = \sqrt{\frac{625}{16}} - \frac{1}{4} = 6$. there-

fore 12 is the Sum of the two Numbers, and from Step 4. $36 - xx + 12 = 39$; that is $xx = 9$, then is $x = 3$; but the greater was $y + x$ by Supposition, therefore $6 + 3 = 9$ the greater Number, $6 - 3 = 3$ the lesser Number sought: Which two will answer the Conditions of the Question.

34 Questions falling under Quadratic Equations.

Q. 2. The Mean of the three Geometric Proportionals being given (12), and the Sum of their Extreams (26); to find the three Numbers, let m be the Mean, $2s$ the Sum of their Extreams, and $2y$ the Difference of their Extreams, then is the greater $s + y$, and the lesser $s - y$. Whence $s + y \cdot m \cdot s - y = m^3$, that is $ss - yy = mm$; whence $ss - mm = yy$, then is $y = \sqrt{ss - mm}$, that is $\sqrt{13 \times 13 - 12 \times 12} = 5$; and by Position y or 5 is half the difference of their Extreams; but half the Sum and half the Difference of two Numbers is always the greater; so that 18 is the greatest. Whence $18 \cdot 12 \cdot (12) \cdot 8 \div \div$ are the three Numbers sought.

Q. 3. The Product of two Numbers is p , and the Sum of their Squares is q ; What are the Numbers?

For their Sum put $2x$, and for their Difference $2y$; then is $x + y$ the greater Number, and $x - y$ the Lesser; their Product is $xx - yy = p$, and the Sum of their Squares is $2xx + 2yy = q$. In the first Equation $xx - p = yy$, in the 2^d, $q - xx = 2yy$; Therefore $xx - p = \frac{1}{2}q - xx$; or $2xx = \frac{1}{2}q + p$; or $xx = \frac{1}{4}q + \frac{1}{2}p$; or $x = \sqrt{\frac{1}{4}q + \frac{1}{2}p}$. Then $\sqrt{\frac{1}{4}q + \frac{1}{2}p}$, is half their Sum, and half their Difference is given, by consequence the Numbers themselves.

Or shorter thus, with one unknown Quantity; Let your Product be p , the Sum of their Squares q , and the Difference of their Squares $2y$. Then is $q + y$ the greater Square, and $q - y$ the Lesser; the Product of whose Roots, viz. $\sqrt{q + y} \times \sqrt{q - y} = p$, that is, $\sqrt{qq - yy} = p$, and to clear the Surd $qq - yy = pp$. Whence as before, $y = \sqrt{qq - pp}$, which is half the Difference of their Squares; but half the Sum and half the Difference of two Squares being given, the Squares themselves are given, and by consequence the Roots.

If it be demanded why I make use of $x + y$ for the greater unknown Number, and $x - y$ for the Lesser, and not rather x for the Greater, and y for the Lesser: I answer, That by this Method, in twenty Quadratics together, if work'd according to Mr. Kersey's Method and his Followers, I avoid for the most part the second Term; which they cannot, and thereby save much Labour. Besides such Questions as by this Method do arise to an affected Quadratic, are commonly extremely difficult, if resolv'd according to the ordinary way: Nay even a simple Quadratic in this Method will sometimes resolve what's very troublefom in that, as may be seen by some of the following Questions.

Q. 4. The Sum of the Extreams of four Numbers in Geometric Proportion, and the Sum of the Means being given to find each of the Terms.

Put $2a$ for the Sum of the Extreams, and $2x$ for their Difference, $2b$ the Sum of the Means, and $2y$ their Difference, and proceed, &c.

Q. 5. The sum of the Squares of two Magnitudes, and the Ratio of their Product to the Square of their Difference being given, to find the Numbers?

Q. 6. The Product of two Numbers, with the Sum of their Cubes, to find the Numbers?

Q. 7. The Square of two Numbers, with the Sum of their Cubes being given, to find the Numbers?

Q. 8. The Difference of the Squares of two Numbers being given, with the Difference of their Cubes, to find the Squares?

For

For forming Equations in any Arithmetical or Geometrical Progression.

§. 1. **I**N any *Arithmetical Progression*, Let a be the first Term, ω the last, n the Number of Terms, s the Sum of all the Terms, and d the Common Difference.

$$\text{Lemma I. } \omega = a + d \times n - 1.$$

$$\text{Lemma II. } s = \frac{1}{2} n \times a + \omega.$$

Any three of these being given, as $a + \omega + s$, or $d + n + s$, &c. the other two are also given: And of these Threes there may be sixty Alternations; which expunging such as are alike, are reduc'd to twenty Cases by Mr. *Oughtred*; and may be all easily resolv'd by the preceding *Lemmas*.

§. 2. In any *Geometrical Progression*, Let a be the first Term (or Antecedent); b the 2^d Term or Consequent, $s - \omega$ the Sum of all the Antecedents, and $s - a$ the Sum of all the Consequents. Then as $a . b :: s - \omega, s - a$, or $as - \omega a = bs - b\omega$, or $as - bs = a\omega - b\omega$; whence $s = \frac{a\omega - b\omega}{a - b}$ if the Progression decreases; or else $s = \frac{b\omega - a\omega}{b - a}$, when it increases.

Of Quadratic Equations in Geometry.

Q. 1. **L**ET the three Sides of any Triangle, a, b, c , be given; to find the length of a Perpendicular let fall upon the Base.

From the preceding first Theorem in Simple Equations;

$\frac{cc + bb - aa}{2}$ to the lesser Segm. of the Base. Whence according to the new way of Notation, $bb - \frac{cc + aa - bb}{2c}$ is equal to the Square of the Perpendicular; whose

Root $\sqrt{bb - \frac{cc + bb - aa}{2}}$ is the Perpendicular sought.

From hence also we have this Theorem for the *Area* of Triangles (3 Sides being given) viz. $\frac{1}{2}c\sqrt{bb - \frac{cc + bb - aa}{2}}$.

Or in a little shorter Terms, $\frac{1}{2}c\sqrt{bb - \frac{1}{2}c + \frac{bb - aa}{2}}$.

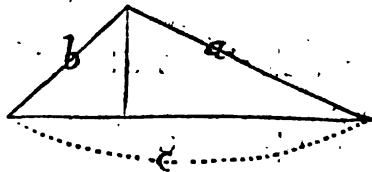

36 Of Quadratic Equations in Geometry.

Hence also we have a *Theorem* for the measuring of *Trapezias*, whose four Sides are given, with the Diagonal, viz.

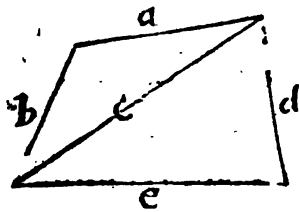

$$\frac{1}{2}c\sqrt{bb - \frac{1}{2}c + \frac{bc-a}{2c}} + \frac{1}{2}c\sqrt{dd - \frac{1}{2}c + \frac{cd-ae}{2c}}$$

Equal to the *Area* of any *Trapezium*, a, b, c, d, e , or to avoid two Multiplications.

$\frac{1}{2}c\sqrt{bb - \frac{1}{2}c + \frac{bc-a}{2c}} + \frac{1}{2}c\sqrt{dd - \frac{1}{2}c + \frac{cd-ae}{2c}}$, shall be the *Area* thereof. This is a very exact way in case of any Dispute; for the surveying any large Plains, Fields, Commons, &c. which are very easily reduced into *Trapezias*.

But the shortest *Theorem* that can possibly be given for the *Areas* of Triangles, is that of Mr. *Oughtred*, provided the literal Expression be not delivered at length as it has been by him, Mr. *Kersey* and others. The known Terms arising to Sur-solids, I would chuse to express it thus, refuming the first Triangle, and putting s for half the Sum of the three given Sides, a, b, c , viz. $\sqrt{sx - ax - bx - c}$, equal to the *Area* of any Triangle, as a, b, c .

Q. 2. There's a Square given, A B C D; and it's demanded to draw a Line C E, to meet A B produc'd. So that the External Part F E, shall be equal to a given Line L.

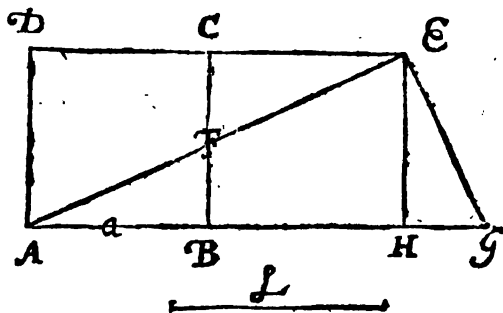

Produce A B indeterminately, as also D C, and draw E G perpendicular to A E, and E H perpendicular to A G.

$$\left. \begin{array}{l} \text{Let } AB = a \\ FE = l \\ CF = x \\ FB = a - x \end{array} \right\}$$

Because of the Similar Triangles we find $\frac{a-x}{x} = AF = EG$: Also this Equation $ax + l = BG$. Whence again $a + \sqrt{aa + l}, \frac{a-x}{x} :: l, x$, or $xa + x\sqrt{aa+l} = ll - lx$, or $xx + xx\sqrt{aa+l} = ll - lx$, or $\sqrt{aa+l} \cdot xx + lx = ll$, or $xx + \frac{ll}{\sqrt{aa+l} + a} = ll$, which arises only to a Quadratic, and may be solv'd after the usual Method.

Q. 3. There is given the Sides of a *Trapezium* ABCD, inscrib'd in a Circle; the *Area* thereof is demanded? Which will arise to a much easier *Theorem* than that of a *Trapezium*, which can't be inscrib'd in a Circle.

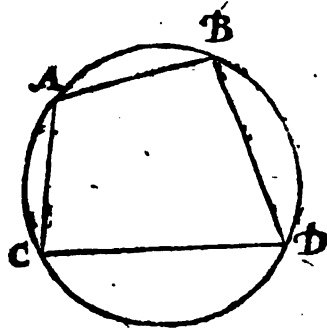

Q. 4.

Q. 4. In a Right-angled Triangle ABC, a the lesser Segment of the Base is only given; yet with this limitation, that the unknown Perpendicular AB, shall be equal to the other Segment of the Base; the side AC is demanded?

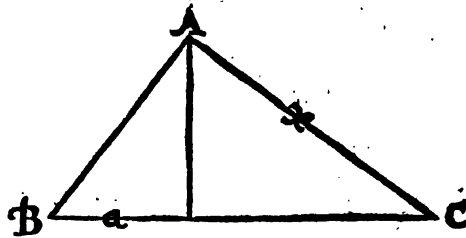

Q. 5. In any Triangle ABC, the Angle BAD, with its opposite side BD; and the Angle DAC, with its opposite side DC are given, to find all the Sides?

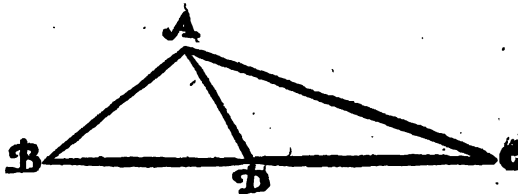

Q. 6. In any Right-angled Triangle ABD, if a Perpendicular AC be let fall from the right Angle upon the opposite Side, thereby dividing the whole into two Triangles similar, and like the whole; at the same time, constituting five Parts, any two of them are given, to find the other three?

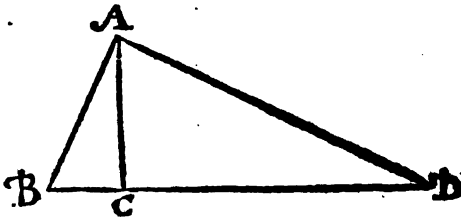

Q. 7. In the same Triangle $AB+BD=p$, and $AC+DC=q$ are given, the Parts are demanded?

Q. 8. In any Right-angled Triangle ABE, the Difference of the Segments of the Hypotenuse KE, with either of the Sides BA or AE, are given, to find all the other Parts?

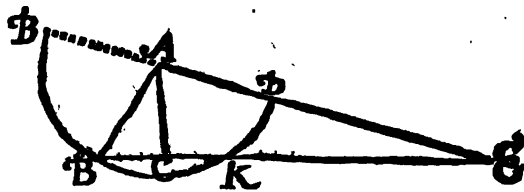

In the same Triangle the Difference of the Legs BA and AE, viz.

DE is given, and the Perpendicular let fall on the Hypotenuse, viz. AC; to find the Hypotenuse, and all the other Parts?

To give *Analytic Theorems* for the inscribing a three, four, five, six, seven, eight, nine, ten, eleven, and twelve-sided Figure in a Circle.

For Equations in Cubics and higher Powers.

To give *Analytic Theorems* for the Trisection, Quadrisection, Quinquisection, Sextisection, &c. of an Arch or Angle.

Geometric Effections or Constructions in simple Equations.

I Suppose all Simple Equations are reducible to this Form, $x = \frac{a^2}{c}$. Then for the Construction $xc = ab$, which resolv'd into Proportionals, gives $c. a :: b. x$: So that to find the Value of x , is only to find a fourth Proportional:

S. 1. The Number of Dimensions in the Numerator, always exceeds that of the Denominator by one, because of Division, (for a Line is Heterogeneous to a Square Cube, &c.); And if it be not so as first, let d (or any other Letter be put for Unity); and let that (or the Powers thereof, if need be) supply what's wanting on either Side, without altering the Value thereof.

For Instance, If $x = \frac{bcd}{e}$, then $z = \frac{bcd}{ed}$; if $z = \frac{mnop}{st}$, then $z = \frac{mnop}{stdd}$; if $z = \frac{lm}{eccr}$, then $z = \frac{lmddd}{stcr}$.

§. 2. Let this Equation be propos'd, $z = \frac{abc}{de}$, take any Quantity, suppose m in the place of $\frac{ab}{d}$, then is $z = \frac{mc}{e}$, which is the *first Form*. Again, let $z = \frac{abcd}{efg}$, take $m = \frac{ab}{e}$ and $n = \frac{cd}{f}$, then is $z = \frac{mn}{g}$ of the *first Form*, 'tis the same if a Simple Equation was still more involved. Suppose $z = \frac{abcdefg}{hilmno}$. take $\frac{ab}{h} = p$, $\frac{cd}{i} = q$, $\frac{ef}{l} = r$; then is $\frac{pqr}{mno} = z$. Again, $\frac{pq}{m} = s$, $\frac{r}{n} = t$; whence $\frac{s}{t} = z$.

§. 3. Let this Equation be propos'd, $z = \frac{ab+ce}{b}$, take $m = b+c$, then is $z = \frac{cm}{b}$. Again, $z = \frac{ab+cd}{e}$, since any Rectangle may be chang'd into another of the same Value, one of the Sides being given; instead of ab take a Rectangle, whose one Side shall be either c or d ; thus $c : a :: b : y$, then $ab = cy$, and $y = \frac{ab}{c}$, whence we have this new Equation $z = \frac{cy+cd}{e}$; then again taking $y+d = m$, $z = \frac{cm}{e}$ of the *first Form*. If there are many Members of the Numerator, reduce them one by one; if they be of several Dimensions, make them of the same by the Multiplication of *Unity* (d) or its Powers into them: If they have different Denominators, reduce them to one, and then work as before; in all which Reductions x , the Number sought, will be a fourth Proportional here.

Of Quadratic Constructions.

ALL Quadratics will fall under some one of these four Forms, or what is very readily deducible from them. (1.) $xx = dd$. (2.) $xx + bx = dd$. (3.) $xx - bx = dd$. (4.) $xx - bx = -dd$.

And when reduc'd, (1.) $x = \sqrt{dd} = d$. (2.) $x = \sqrt{dd + \frac{bb}{4}} - \frac{b}{2}$. (3.) $x = \sqrt{dd + \frac{bb}{4}} + \frac{b}{2}$. (4.) $x = \sqrt{\frac{bb}{4} - dd} + \frac{b}{2}$.

§. 1. If the first, there's no need of any construction for $x = d$; if $xx = bd$, here it's evident that x is a mean Proportional betwixt b and d ; for $b : x :: x : d$: Whence $bd = xx$ as before. Describe a Circle, whose Diameter let be $b + d$ as one Line, and at their point of meeting erect a Perpendicular x sought, which is a mean proportional betwixt b and d , (by 13. e 6.)

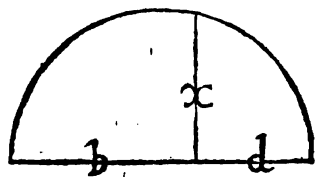

§. 2. Let the second Case be propos'd, $x = \sqrt{dd + \frac{bb}{4}} - \frac{b}{2}$ at right Angles erect d , and $\frac{1}{2}b$; the Squares of which (by 47. e. 1.) are equal to that of the Hypotenuse $= dd + \frac{bb}{4}$, the Root of which less'n'd by $\frac{1}{2}b$, gives x sought.

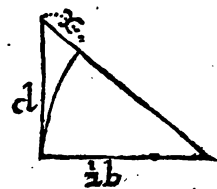

The

The third Case is $x = \sqrt{dd + \frac{bb}{4} + \frac{b}{2}}$, which differs not from the last, save only that $\frac{1}{2}b$ is not taken out of the *Hypotenuse*, but added thereto to make up the Value of x sought.

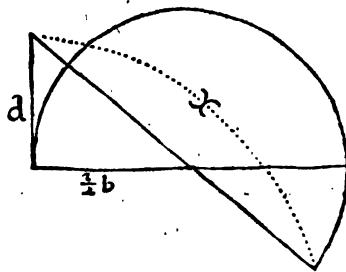

The fourth and last Case is, $x = \sqrt{\frac{bb}{4} - dd + \frac{b}{2}}$. $\frac{bb}{4} - dd$, is a Rectangle made by the Multiplication of $\frac{1}{2}b + d$ & $\frac{1}{2}b - d$, describe a Circle whose Radius shall be $\frac{1}{2}b$; to which add d in the same Line, and from $\frac{1}{2}b$ subduct d as in the Figure, then is the Perpendicular which stands on the meeting of $\frac{1}{2}b + d$, and $\frac{1}{2}b - d$, a mean Proportional betwixt them and the Square thereof, is equal to their Rectangle; to the Root of which (that is the Perpendicular it self) if $\frac{1}{2}b$ be added in one Line, it gives the Value of x sought.

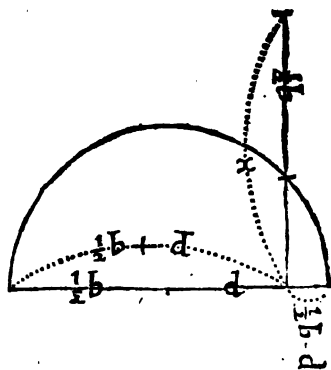

All affected Quadratics are reducible to one of the three last Forms, I shall give one perplex'd Instance for all; $xx + x = dd - aa - \frac{d^2cc}{bb - aa}$, take $dm = aa$; then instead of $dd - aa$, we have $dd - dm$; take k for $d - m$, then is $dk = dd - aa$. Again, let $aa = br$, then $bb - aa = bb - br$; take $p = b - r$, and we have $bp = bb - aa$, then also is $dd - aa - \frac{d^2cc}{bb - aa} = dk - \frac{d^2cc}{bp}$.

Yet again, take $n = \frac{dd}{b}$ and $o = \frac{cc}{p}$, then is $dk - no = dk - \frac{d^2cc}{bp}$.

Again, take $no = dg$, then is $dk - no = dk - dg$; and if b be assum'd for $k - g$, $dk - dg = db$.

Lastly, Take a mean proportional betwixt d and b : Suppose l , then $dl = ll$, then will $dd - aa - \frac{d^2cc}{bb - aa} = ll$, then also is $xx + x = ll$, which was to be done.

Those that would see more of the Practice of Geometrical Constructions, may consult *Oughtred's Clavis*, and *De Cartes* Geometry.

As for the Construction of Cubic, Biquadratic, and higher Equations, 'tis necessary first to understand *Conic Sections*, therefore I omit that as foreign to my Purpose at present.

Of Cubic, Biquadratic, and higher Equations.

THE Origination of a Cubic Equation, is the same with that of an affected Quadratic. *Ex. Gr.*

40 Of Cubic, Biquadratic, &c. Equations.

1. Put $x = a$
 $x = b$
 $x = c$

Then is $x - a = 0$
 $x - b = 0$
 $x - c = 0$

$$\begin{array}{r} xxx - axx + abx \\ - bxx - acx \\ - cxx + bcx - bcd = 0. \end{array}$$

2. Put $x = a$
 $x = b$
 $x = -c$

Then is $x - a = 0$
 $x - b = 0$
 $x + c = 0$

$$\begin{array}{r} xxx - axx + abx \\ - bxx - acx \\ + cxx - bcx + bcd = 0. \end{array}$$

3. Put $x = -a$
 $x = -b$
 $x = +c$

Then is $x + a = 0$
 $x + b = 0$
 $x - c = 0$

$$\begin{array}{r} xxx + axx + abx \\ + bxx - acx \\ - cxx - bcx - bcd = 0. \end{array}$$

I omit the last Case, where, a, b, c , are all Negative, which is impracticable.

1. After the same manner any Biquadratic, Cubiquadratic, or higher Equation may be deriv'd, where there will be always so many Values of the unknown Quantity, as is the *Index* of the *highest Power*, sometimes Positive, sometimes Negative, sometimes Imaginary, and sometimes Mix'd.

2. The *Coefficient* of the second Term, is the Sum of all the Roots under contrary Signs.

3. The *Coefficients* of the third Term, is the Rectangles of all the Roots so many ways as they can be taken, *viz.* three in a Cube, four in Biquadrate, &c. The *Coefficient* of the fourth Term, if we proceed to Biquadrates, Cubiquadrates, &c. is the Sum of all the Solids of the Roots, so many ways as they can be taken. The *Coefficient* of the fifth Term will be the Sum of all the Surfsolids of the Roots, so many ways as they can be taken; and so on *ad infinitum*. Lastly, The Absolute known Number in the Square, is the Rectangle of the two Roots; in the Cube, the Solid of the three Roots; in the Biquadrate, the Sur-solid of the four Roots, &c.

4. When the *Coefficients* are mix'd, if the Sum of the Negative Roots taken together, is equal to the Sum of the Positive, the second Term is destroy'd in that Equation: Also if the Rectangles of the Negative Roots are equal to the Rectangles of the Positive, the third Term will be destroy'd; and so on.

As for the Determination of the Quality of Roots in a Cubic Equation, and higher if need be, *viz.* how many *Positive*, and how many *Negative*, &c. I think we need not follow Mr. *Harriot's* Method, which is very much perplex'd in the deriving variety of Cases, as by his *Reciprocals*, his *parting a Simple Quantity* into the *Form* of a Binomial, &c. All the sixteen Cases in Cubics (for so many I find) are very easily and naturally derived, only from the different Combinations of the Values of the *Coefficients* in the three preceding Originations.

I shall give one Example of my Method, by which all the rest will be evident: Let the second Case be resum'd where the *Quantity* arises, from two Positive Roots and one Negative.

From the different Combinations of the *Coefficients* in this Example, there will arise three of the sixteen Cases in Cubics before the second or third Term be taken away.

Let $a + b$ taken together be either greater or lesser than c ,

$$\begin{array}{r} x = a \quad x - a = 0 \\ x = b \quad x - b = 0 \\ x = -c \quad x + c = 0 \\ \hline xxx - axx + abx \\ - bxx - acx \\ + cxx - bcx - abc = 0. \end{array}$$

(for

(for should they be equal, the 2^d Term would be destroy'd) then by expressing the Coefficient of the second Term in one Letter: Suppose p , there can be only two Alternations according as the two Positive Roots, or the one Negative prevails, viz. $-p$, or $+p$.

For the Coefficients of the third Term: Suppose c either greater, equal, or lesser than $a + b$. First, If c be greater than $a + b$, ac and bc together will be greater than ab , because bc by it self is greater than ab . (2.) If c be equal to $a + b$, $ac + bc$ will be greater than ab , because ac it self is greater than ab , which two are but one Case. Again, supposing c lesser than $a + b$, the Defect will be either great or little. If c be moderately less than $a + b$, then $ca + cb$ may be taken greater than ab , which is a second Alternation. Lastly, If c be taken very little, $ca + cb$ may be lesser than ab ; which is the third Alternation, and all that can be made in the Coefficients of the third Term.

Add these three Alternations to the two first made by the Coefficients of the second Term, and let q stand for the Total of the last Coefficients, and they will arise thus.

$$\left. \begin{array}{l} xxx - pxx \\ xxx + pxx \end{array} \right\} \text{For the first Alternation:}$$

$$\text{For the Second, } \left. \begin{array}{l} xxx - pxx \\ xxx + pxx \end{array} \right\} \begin{array}{l} - qx \\ + qx \end{array} - abc = 0.$$

$$\text{For the Third, } \left. \begin{array}{l} xxx - pxx \\ xxx + pxx \end{array} \right\} - qx - abc = 0.$$

From such different Alternations, and Values of all the Coefficients of every Term in any Equation, there's a Necessity that so often as $+$ follows $+$, or $-$ follows $-$, (all the Terms being put over to one Side) so many are the Negative Roots; and so often as $+$ follows $-$, or the contrary, so many are the Positive Roots in any Equations, (I mean of real Ones).

Upon these Considerations I determine the Qualities of the Roots of all the Cases in the three preceding Games, as follows.

1. Case, {	1. $xxx - pxx + qx = +r$	{	All the Roots are Positive:
2. Case, {	2. $xxx - pxx - qx = -r$	}	The two Positives prevail, and the Negative is moderately big.
	3. $xxx - pxx + q = -r$		The two Positives prevail, and the Negative is very small.
	4. $xxx + pxx - qx = -r$		The Negative is greater than the two Positives.
3. Case, {	5. $xxx + pxx - qx = +r$	}	The two Negatives prevail, and the Positive is moderate.
	6. $xxx + pxx + qx = +r$		The two Negatives prevail, and the Positive is very small.
	7. $xxx - pxx - qx = +r$		The Positive is greater than the two Negatives.
2. Case, {	8. $xxx - pxx * = -r$	}	Two Positives greater than one Negative.
	9. $xxx + pxx * = -r$		One Negative Root and two Imaginary.
3. Case, {	10. $xxx + pxx * = +r$	}	Two Negatives greater than one Positive.
	11. $xxx - pxx * = +r$		One Positive Root and two Imaginary.
2. Case, {	12. $xxx * + qx = -r$	}	One Negative Root and two Imaginary.
	13. $xxx * - qx = -r$		Two Positives equal to one Negative.
3. Case, {	14. $xxx * - qx = +r$	}	Two Negatives equal to one Positive.
	15. $xxx * + qx = +r$		One Positive Root and two Imaginary.
1, 2, or 3 ^d Case, {	16. $xxx * * = +r$	}	One Positive Root and two Imaginary.

42 *Of dissolving Compound Equations.*

☞ *Note*, That if in the 13th or 14th Forms, if $\frac{1}{2}p^3$ be greater than $\frac{1}{2}qq$, the two Positive Roots in the first, and the two Negative Roots in the last will be Imaginary.

From the three preceding Cases only, may also be deriv'd the 46 different Combinations in Biquadratics, and also of yet higher Equations, but this would be a Business of greater Labour than Use, and therefore I omit it.

I shall also pass over the Method of resolving these Cubics as deliver'd by *Cardan*, because his Rules reach not all Cases as where the Root is under Unity: Or upon supposition they did, what a tedious Operation (after that of taking away the second Term) would it amount to, especially if the Root sought were irrational? We must extract two Squares and two Cubes, before we can arrive to what we want. But for such as are in love with this Method, I shall barely set down the *Theorems* for them as follows, reserving a full Resolution of them, (and higher Equations) till we come to the easier Methods of *infinite Approximations*.

$$\begin{aligned}
 x^3 * + qx = +r. \text{ Root. } x &= \sqrt[3]{(3)r + \sqrt{\frac{1}{4}rr + \frac{1}{27}q^3}} - \sqrt[3]{(3)r - \sqrt{\frac{1}{4}rr + \frac{1}{27}q^3}} \\
 x^3 * - qx = +r. \text{ Root. } x &= \sqrt[3]{(3)r + \sqrt{\frac{1}{4}rr - \frac{1}{27}q^3}} + \sqrt[3]{(3)r - \sqrt{\frac{1}{4}rr - \frac{1}{27}q^3}} \\
 x^3 * - qx = -r. \text{ Root. } x &= -\sqrt[3]{(3)r + \sqrt{\frac{1}{4}rr - \frac{1}{27}q^3}} - \sqrt[3]{(3)r - \sqrt{\frac{1}{4}rr - \frac{1}{27}q^3}} \\
 x^3 * + qx = -r. \text{ Root. } x &= -\sqrt[3]{(3)r + \sqrt{\frac{1}{4}rr + \frac{1}{27}q^3}} + \sqrt[3]{(3)r - \sqrt{\frac{1}{4}rr + \frac{1}{27}q^3}}
 \end{aligned}$$

Of dissolving Compound Equations.

FROM the Origination of Compound Equations, we have a Method of dissolving them again, (if by any means we can discover any of the Roots) *viz.* by depressing a Biquadratic to a Cubic, a Cubic to a Quadratic, a Quadratic to a Lateral. For Instance, Let the following Quadratic $xx - 5x = 6$, be generated from the Roots 2 and 3.

$$\begin{array}{r}
 x = 2 \quad x - 2 = 0 \\
 x = 3 \quad x - 3 = 0 \\
 \quad \quad \quad \underline{xx - 2x} \\
 \quad \quad \quad -3x - 6 \\
 \hline
 x - 2 = 0 \quad \left. \begin{array}{l} xx - 5x - 6 = 0 \\ \underline{xx - 2x} \end{array} \right\} (x - 3 = 0 \\
 \quad \quad \quad \underline{-3x - 6} \\
 \quad \quad \quad \underline{-3x - 6}
 \end{array}$$

Suppose I had by some means discovered that one of the Roots or Values of x was 2, then the other would be found by Division, as in the Operation. Imagine the same in Equations more Compound.

To find all the Roots of a Cubic Equation.

Suppose in a Cubic Equation, whose second Term is taken away, I have occasion for all the Roots; put $2x$ for the Sum of the two, whether Positive or Negative, $2y$ their Difference; $2x$ will also be the third, whether Negative or Positive, because it must be equal to the other two, or the second Term could not be destroy'd; then is $x + y$ the greater Root of the two, $x - y$ the Less. Let the three Roots be multiply'd with their own Signs, so many ways as they can be taken to form a Coefficient equal to that of the third Term, and there arises $-3xx - yy$.

Let

To find all the Roots of a Cubic Equation. 43

Let any Equation be propos'd $\left\{ \begin{array}{l} xxx - px = -q \\ xxx - px = +q \end{array} \right\}$ Then from the Combinations of the Coefficients of the third Term, we have this Equation, $-3xx - yy = -p$, or $3xx + yy = p$, or $p - 3xx = yy$, or $y = \sqrt{p - 3xx} = \frac{1}{2}$ the Difference of the two Roots. So that having the greatest, whether Negative or Positive, given or found first; and by consequence the Sum, or half the Sum of the other two, all the three are given at once by the preceding Theorem; only we are to remember, that $2x$ is equal to z , and by equivalent Substitution $y = \sqrt{p - \frac{1}{4}zz}$. Ex. $xxx - px = -6$, or $xxx - 7x = -6$. Let the greatest Negative z (=to the other two Positive) be given or found, *viz.*

Suppose 3; then is $\frac{1}{2}z + \sqrt{p - \frac{1}{4}zz}$, the greater $\left\{ \begin{array}{l} \text{Positive,} \\ \text{Negative,} \end{array} \right.$ and $\frac{1}{2}z - \sqrt{p - \frac{1}{4}zz}$, the lesser $\left\{ \begin{array}{l} \text{Positive,} \\ \text{Negative,} \end{array} \right.$ *viz.* $\frac{1}{2}3 + \sqrt{7 - \frac{1}{4}9} = 1.5 + .5 = 2$ the greater $\left\{ \begin{array}{l} \text{Positive,} \\ \text{Negative.} \end{array} \right.$

and $1.5 - .5 = 1$ the lesser $\left\{ \begin{array}{l} \text{Positive,} \\ \text{Negative.} \end{array} \right.$ And hence also we have another Determination of Imaginary Roots, *viz.* when these Theorems, or one of them, infer an Impossibility.

But if no Term be wanting, as in this Equation, $xxx - px - q = -r$, where there are two Positive Roots, and one Negative moderately big; let $2x$ be the Sum of the Positive, $2y$ their Difference; then is $x + y$ the greater Positive, $x - y$ the Lesser, and $2x - p$ the third Negative; as is evident from the Nature of the Coefficients in the second Term; whence $2x - p = z$, or $\frac{z+p}{2} = x$.

Let the Roots, with their proper Signs, be multiply'd, so many ways as they can be taken, and their Difference equated to the Coefficient of the third Term, *viz.* $-q$, and then there will arise $-3xx - yy + 2px = -q$, or $2px + q - 3xx = yy$, or $y = \sqrt{2px + q - 3xx}$; but x was found before equal to $\frac{z+p}{2}$, z being the Negative Root; which substituted equivalently, gives $y = \frac{1}{2} \sqrt{pp + 4q - 3zz - 2pz}$: Whence as before, $\frac{1}{2} \sqrt{pp + 4q - 3zz - 2pz} + z + p$ equal to the greater Positive, and $\frac{1}{2} \sqrt{pp + 4q - 3zz - 2pz} - z - p$, equal to the lesser Positive: But this supposes z

the Negative or single Root first found. The like will serve for all the rest of the Cases, relation being had to the Signs of the Roots in forming the Theorem, the single Root being first found out, and the Sum and Difference of the other two, whether Positive or Negative, being call'd $2x$, $2y$; but if all the Roots be Positive, let $2x$ be the Sum of the lesser, $2y$ their Difference, and let the greatest be $2x + p$. Hence also in Cubic Equations having all the Terms, we have a Method for determining imaginary Roots, *viz.* when the preceding Theorems, or one of them infer an Impossibility.

Of Increasing and Decreasing the Value of an unknown Equation without destroying it.

Suppose I would double this Quadratic $xx + bx = d$; Multiply each Term by a Series of Proportionals, beginning with *Unity*, whose second Term is 2. Thus $1xxx + 2xbx = 4xd$, which destroys the Equation; restore it again by a backward Multiplication of the same Proportionals $4 \times 1xxx + 2 \times 2xbx = 1 \times 4xd$; Instead of x take another unknown Quantity, y , supposed equal to $2x$, then is $xx = \frac{1}{4}yy$: And there results another Equation, which compar'd with the first, satisfies the Demand, *viz.* $4 \times 1xxx + 2 \times 2xbx = 1 \times 4xd$

$$yy + 2by = 4d \quad \Bigg\} \text{ If}$$

44 Of Increasing & Decreasing the Value of Equations.

If I would have an Equation which shall be $\frac{1}{3}$ of this Cubic $xxx + bxx + cx = d$, multiply by a Series of Proportionals, beginning with 1, whose second Term is $\frac{1}{3}$, and put y for $\frac{1}{3}x$, then by the preceding Method we shall have this new Equation, $yyy + byy + cy = \frac{1}{27}d$. Or more generally thus, put a for any Number, Integer, or Fraction, and reassume the preceding Equation, $xxx + bxx + cx = d$, then is where the Value of y to x , is as a to 1. $yyy + aby + acy = aad$.

The Uses of this Artifice are very great; some of which are these.

Use 1. To free an Equation from Fractions. Suppose $xx + \frac{1}{3}bx = d$, putting $y = \frac{1}{3}x$, we have $yy + by = 9d$. Again, suppose this Equation was propos'd, $xxx + \frac{b}{a}xx = d$; that is, $xxx + \frac{b}{a}xx + 0x = d$, putting $y = ax$, we have $yyy + byy = aad$.

Use 2. To take away the second Term in any Equation. Suppose $xx + bx = d$, put $y = \frac{1}{2}b = x$.

Then is $yy - by + \frac{1}{4}bb = xx$ } = d By the same Method the second Term in a Cubic may be destroy'd; only remember that
and $\frac{1}{4}bb - by = \frac{1}{4}bb - bx$ }
 $yy - \frac{1}{4}bb = d$. $y \pm \frac{1}{2}$ the Coefficient in the Square, $y \pm \frac{1}{3}$ the Coefficient in the Cube $y \pm \frac{1}{4}$, the Coefficient in the Biquadrate, &c. must be taken with the contrary Sign to the second Term; for if the same Sign be taken, the second Term will doubled not taken away.

Use 3. To take away all the Coefficients in a Cubic Equation. Which I think has not yet been done by any one; and perhaps others may make better use of it than I can at present. Suppose the second Term in a Cubic Equation taken away, or else that this is given $xxx + bx = d$, assume $y = x\sqrt{\frac{1}{b}}$, ($\sqrt{\frac{1}{b}}$, being a mean Proportional betwixt $\frac{1}{b}$ and Unity); Then multiply by a term of continual Proportionals in that Series as before; and instead of $xxx + bx = d$, we have $1xxx + \sqrt{\frac{1}{b}}x + \frac{1}{b}x = \frac{d}{b}\sqrt{\frac{1}{b}}$ that is by equivalent Substitution $yyy + y = \frac{d}{b}\sqrt{\frac{1}{b}}$.

In all the preceding Cases, as soon as the Value of y is found, the Value of x is also discover'd, y being always taken in some certain Proportion to x .

Of the Punctuation of Affect'd Equations.

LET a Biquadrate be made from the Binomial $x + a = p$, according to the former Genesis of Powers, and it will arise to this,

$xxxx + 4bxxx + 6bbxx + 4bbb + bbbb = pppp$. Again, let a Biquadratic be found from several different Values of x , thus;

$$\left. \begin{array}{l} x - b = 0 \\ x - c = 0 \\ x - d = 0 \\ x - f = 0 \end{array} \right\} \text{And we have} \left. \begin{array}{l} xxxx - bxxx + bxxx \\ - cxxx + bdx \\ - dxxx + cdxx - bcxc \\ - fxxx + bfxx - bcfx \\ + cfxx - bdfx \\ + dfxx - cdfx + bcd = 0. \end{array} \right\} \text{this Genesis.}$$

Now confounding the Homogeneous Coefficients, and putting them all into one, we may represent their Totals thus

$$x^4 - mx^3 + nxx - pppx = -qqq.$$

Of the Punctuation of Adefected Equations. 45

In this and the preceding *Genesis*, (from one Value of x , omitting the distinction of the *Uncia*) 'tis evident that the Coefficients encrease in their Power, as the highest unknown Term decreases, and that the *last absolute known Quantity* is of the same Power as the First. Imagine the same under different Signs; also if one or more of the Terms be intercepted or lost, the remaining will yet keep their Places. Hence in *Numeral Equations*, suppose $xxxx + 3x^3 + 16xx + 125x = 1000$, the Coefficients are first Lateral, then Quadratic, then Cubic, &c. and 'tis no matter whether they are figurate Numbers or not, *viz.* exact Squares, Cubes, &c. they are always supposed of that Nature. Hence we have these two Confectaries.

1. If the Root of the Coefficient (in any Place) be continually multiply'd to its degree of Adefection, and then by it self again, the last Product shall be of the same Power with the highest unknown Term in the Equation.

For Instance, $x^4 - mx^3 + n^2x^2 - p^3x = -9999$, the Coefficient m is a Lateral, (therefore it self a Root); and if Cub'd, (for so is the highest Power which it is join'd to, or its degree of Adefection) it becomes mmm ; which multiplied again by it self, becomes m^4 of the 4th Power, as is $xxxx$. Again, in mx^3 , the Root of m is n , its degree of Adefection is a Square m , which multiply'd into it self, *viz.* mm , becomes mmm a Biquadrate. Lastly, p^3x the Root of p Cube, is p , its degree of Adefection, is only Lateral: Therefore p (the Side) \times ppp (the Coefficient it self) produces p^4 .

2. If the absolute known Power be divided by any one of the Coefficients, the Quote will be of the same degree of Adefection with the place of such Coefficient, *viz.* Lateral, if the Adefection be Lateral; Quadratic, if the Adefection be Quadratic, &c.

For Instance, $x^4 + 3xxx + 16xx + 125x = 1000$: if 1000 be divided by 3, the Quote is Cubic; if by 16, the Quote is Quadratic; if by 125, 'tis Lateral. From hence then, and the preceding *Genesis*, we have a Method of Pointing any adefected Equation in order to its Extraction.

It's evident from the *Formation of Powers*, that a Square must be pointed every second Figure, (beginning from the Right) a Cube every third, a Biquadrate every fourth; and so on. For suppose 57209 was given to be squar'd, 5 has four places after it; therefore its Square 25 will have eight Ciphers; or if Cub'd, 'tis 125 with twelve Ciphers annex'd; and so on, every Cipher or Place following a Figure in the Root, making 2 in the Square, 3 in the Cube, &c.

Let any Equation be propos'd, (in order to its pointing). Suppose without any Coefficient $xxx - xx = 186494880$. From the preceding *Genesis* 186494880 is Cubic, because so is the highest unknown Term, therefore let it be pointed at every third Figure thus, 186494880. But since it also contains in it the Negation of xx , therefore imagine it also pointed as a Square, thus, 186494880, but with the same Number of Points, because xxx is no oftner contain'd in 186494880, than xx is supposed to be taken out of it.

There are three Cases that can only happen in pointing.

1. Where the number of Figures in the Coefficients are regular, and will admit of an equal Number of Points according to their respective Powers. For Instance, $xxxx + 13xxx + 237xx + 5927x = 100000$, where each place has two Points, determining the Value of x to consist of two Integers; so that we have for the first pointing this Equation $x^4 + 1x^3 + 2xx + 5x = 10$ near; whereby the Value of x in its first Figure is readily discover'd. 'Tis the same if interrupted, *viz.* $xxxx + 9532x = 123579$, then $x^4 + 9532x = 12$; or if the natural Order of Places be inverted, *viz.* $x^4 + 3537xx + 35xxx = 2598372$, where $x^4 + 35xx - 3x^3 = 259$.

2. The second Case is call'd a *Devolution*, where the Number of Figures is too short in some of the Coefficients: And here it's easier than before to find the Value of x as to the first Figure, for we have no more to do than prefix so many Ciphers in each, as are the number of Figures that are wanting.

46 Of the Punctuation of Adfected Equations.

For Instance, $xxx + 24x = 587914372$; that is, $xxx + 00024x = 587914372$. Whence $xxx + 0x = 587$, or $xxx = 587$.

3. The third, which is called a *Case of Anticipation*, where some of the Coefficients run beyond their just Number of Punctations, and this is much more troublesome than either of the former.

For Instance, $xxx + 4xx + 376958x = 753922$; which pointed as before, would be $xxx + 04xx + 376958x = 753922$; or $x^3 + 3769x = 753$, where $x = .1$, whereas 'tis equal to 2 precisely. The best Expedient I can meet with in this, (if the Figures have but one Punctuation) is that of Dr. Wallis, who supposes the first Figure arising to be 1, 10, 100, 1000, &c. Or downwards; .1. .01 .001, &c. And then having found by trial whether it lies betwixt 1 and 10, or 10 and 100, &c. We takes the Medium 5, 50, &c. till he meets with it. But this Expedient will also prove fruitless for the second Figure, if the *Anticipation* be large: we have therefore but one way left us that I know of, and that is the incomparable Method of a *Converging Series*, lately discover'd by the ingenious Mr. Raphson; which though it might be help'd by Punctuation, as in the two preceding Cases, yet it has no absolute Necessity of it, for by assuming any Number at pleasure, no matter how far off the Truth, (as to the possibility of its accomplishing the End) it will converge to it infinitely quicker than by any Essays or Trials whatever in the most perplex'd *Anticipations*, therefore extremely ready and easy in the other Cases. The further Uses of it are best explain'd by Examples; however I thought it necessary to say something of Punctations here, having occasion to use them hereafter, because Mr. Raphson has not done it in his excellent *Series*, but only refer'd to *Vieta*, *Oughtred*, &c. which perhaps every one has not at hand, or can't read them in Latin. But Mr. Raphson's Business was not Repetition, or a troubling himself with what was requisite to be known before he could be understood, presuming reasonably enough, that his Reader was not ignorant of what Advancements had been made before him in the *Emergo Numerosa* of the aforementioned Authors.

Of Infinite Approximations, or a Numeral Converging Series for all Adfected Equations whatever.

Example 1.

LET any Equation be propos'd, suppose $xx = a$.

1. Put p (a known Quantity) $+ y$ (an unknown Quantity) equal to x . Then is $p + y$, or $pp + 2py + yy = (xx =) a$.

2. By Transposition $2py = a - pp - yy$, or $y = \frac{a - pp - yy}{2p}$; or which is the same thing, $y = \frac{a - pp}{2p} - \frac{yy}{2p}$. But $x = p + y$ by Position. Ergo, $x = p + \frac{a - pp}{2p} - \frac{yy}{2p}$ in which Equation $p + \frac{a - pp}{2p}$ is wholly a known Quantity, and $-\frac{yy}{2p}$ an unknown.

3. Put $q = p + \frac{a - pp}{2p}$, and $-z = -\frac{yy}{2p}$, then is $x = q - z$. Then also is $qq - 2qz + zz = (xx =) a$; and by Transposition and Division as before $z = \frac{qq - a}{2q} + \frac{zz}{2q}$. But $x = q - z$ by Position; Ergo, $x = q + \frac{a - qq}{2q} - \frac{zz}{2q}$ where the known $q + \frac{a - qq}{2q}$ is evidently less than the former known Quantity q , because $qq < a$.

4. Put

4. Put $r = q + \frac{a-rr}{2r}$, and $-v = -\frac{xx}{2r}$; and by the same Method of procedure we shall have $x = r + \frac{a-rr}{2r} - \frac{vv}{2r}$ the known Quantities which are too great being still decreas'd.

5. Put $s = r + \frac{a-rr}{2r}$ and $-o = -\frac{ss}{2r}$, and by a like repeated Process there will arise $x = s + \frac{a-ss}{2r} - \frac{oo}{2r}$; which last $-\frac{oo}{2r}$ will be so very small, that we need make no subduction for it, if the Value of a be not above 32 Figures, which I think is sufficient for Practice.

Hence then by collecting the whole together we have this Series ;
 $p + \frac{a-pp}{2p} (=q) \quad q + \frac{a-qq}{2q} (=r) \quad r + \frac{a-rr}{2r} (=s) \quad s + \frac{a-ss}{2s} = x$ *proximè*; or according to Mr. Raphson's Method, $p + \frac{a-pp}{2p}$ only, repeated at pleasure is equal to x , where the Value of p always changes at every Operation ; and the Value of a is first 1 Punctuation, then 2, then 4, then 8, then 16, and so on as far as any one pleases to prosecute it, from the same Considerations which I mention'd in the preceding Series for Extraction of Square Roots.

Examp. 2. Let this adfectèd Quadratic be propos'd, $xx + bx = c$.

1. Put $x = p + y$; then is $pp + 2py + yy \left\{ \begin{array}{l} = xx \\ = bx \end{array} \right\} = c$. That is,

$$y = \frac{c-pp-bp-yy}{2p+b}; \text{ or which is the same thing, } y = \frac{c-pp-bp}{2p+b} - \frac{yy}{2p+b}, \text{ but}$$

$$x = p + y; \text{ therefore } x = p + \frac{c-pp-bp}{2p+b} - \frac{yy}{2p+b}. \text{ Now putting}$$

$q = p + \frac{c-pp-bp}{2p+b}$, and $-z = -\frac{yy}{2p+b}$. By the same Procedure repeated at pleasure, we have this Series,

$$p + \frac{c-pp-bp}{2p+b} (=q) \quad q + \frac{c-qq-bq}{2q+b} (=r) \quad r + \frac{c-rr-br}{2r+b} (=s) \quad s + \frac{c-ss-bs}{2s+b} = x.$$

Or according to Mr. Raphson's Method, $p + \frac{c-pp-bp}{2p+b}$ only repeated as far as there is occasion, is equal to x , p acquiring a new Value every Operation ; also b and c changing their Value, reaching first to one Punctuation, then to two, then to four, then to eight, and so on, or at least as far as there are Punctuations; and when there's no more their Value is fix'd, the p will always converge and vary *ad infinitum*.

Examp. 3. Let this adfectèd Cubic Equation be propos'd, $x^3 + bxx + cx = d$.

Putting $x = p + y$, we have this new Equation resulting. $\left. \begin{array}{l} pp^2 + 3pp + 3py + yy \\ bpp + 2bpy + byy \\ cp + cy \end{array} \right\} \left\{ \begin{array}{l} = xxx \\ = bxx \\ = cx \end{array} \right\} = d$

$$\text{Then is } \frac{d-pp^2-bpp-cp}{3pp+2bp+c} - \frac{3py-by-y-y}{3pp+2bp+c} = y; \text{ But } p+y=x. \text{ Therefore}$$

$$x = p + \frac{d-p^2-bp^2-cp}{3p^2+2bp+c} - \frac{3py-by-y-y}{3pp+2bp+c}. \text{ Now putting } q \text{ for all that's known, as be-}$$

fore, and $-z$ for all that's unknown, and so repeating the same Process arbitrarily, we shall have this Series ;

$$p + \frac{d-p^2-bp^2-cp}{3p^2+2bp+c} (=q) \quad q + \frac{d-q^2-bq^2-cq}{3q^2+2bq+c} (=r) \quad r + \frac{d-r^2-br^2-cr}{3r^2+2br+c}, \text{ \&c.} = x.$$

And so on in all higher Equations, representing always all those Quantities which are affected with the Powers of the unknown *assum'd Quantity* by another unknown, thereby driving forward and decreasing that unknown Value, till it becomes so small

small that it may safely be rejected, and what is known taken for Truth it self, as being indeterminately near it: remembering also, that all the Values of the Coefficients, as also the last *absolute known Number* change, so long as the Punctations last; but no longer, though the Value of the assum'd Quantity will ever converge and alter.

Before I proceed to Examples, I shall give the *Series* for the four Cases in Quadratics, as also the fourteen useful Cases in Cubics, leaving others to calculate higher as they have occasion.

The four Quadratic Series.			
1. $xx+bx=c$	$x=\frac{c-p-b \times p}{2p+b}+p$	5. $xxx+bx=c$	$x=\frac{c-p-b \times p}{3p+2b \times p}+p$
2. $xx-bx=c$	$x=\frac{c+b-p \times p}{2p-b}+p$	6. $xxx-bx=c$	$x=\frac{c+b-p \times p}{3p-2b \times p}+p$
3. $-xx+bx=c$	$x=\frac{c+p-b \times p}{b-2p}+p$	7. $-xxx+bx=c$	$x=\frac{c+p-p \times p}{2b-3p \times p}+p$
4. $xx=c$	$x=\frac{c-p}{2p}+p$	8. $x^2+bx^2+cx=d$	$x=\frac{d-p-p \times p}{c+3p+2b \times p}+p$
The fourteen Cubic Series.		9. $x^3-bxx+cx=d$	$x=\frac{d+b-p \times p}{c+3p-2b \times p}+p$
1. $xxx=c$	$x=\frac{b-p^3}{3p^2}+p$	10. $x^3+bx-cx=d$	$x=\frac{d+c-p-p \times p}{3p+2b \times p-c}+p$
2. $xxx+cx=d$	$x=\frac{d-p-p \times p}{3p+c}+p$	11. $x^3-bxx-cx=d$	$x=\frac{d+b-p \times p}{3p-2b \times p-c}+p$
3. $xxx-bx=d$	$x=\frac{d+c-p \times p}{3p-c}+p$	12. $-x^3+bx+cx=d$	$x=\frac{d+p-p \times p}{c+2b-3p \times p}+p$
4. $-xxx+cx=d$	$x=\frac{d+p-p \times p}{c-3p}+p$	13. $-x^3+bx+cx=d$	$x=\frac{d+p+p \times p}{c-3p-2b \times p}+p$
		14. $-x^3+bx-cx=d$	$x=\frac{d+p+c-p \times p}{2b-3p \times p-c}+p$

No one that understands how to convert a Literal Theorem into a Numeral Operation, can be ignorant how to apply the preceding *Theoretic Series*. Yet notwithstanding the Method is so very natural and easy, I shall give some Examples.

I have formerly taken notice, that in adfected Quadratics, if the *Homogeneous Comparationis* arises high, this *Series* is preferable to the common Way; but in all higher Equations whatever, it infinitely exceeds any *Exegisis Numerosa* that has yet been found out.

Let this Adfected Quadratic be propos'd, $xx+587x=987459$, and let the Value of x be found to five or six Places in Decimals; which is the same thing as to find the Value of x (if Rational) where the *absolute known Quantity* arises to twelve Places.

Of Infinite Approximations.

Let $b = 587$, and $d = 987459$. $xx + 587x = 987459$
 After Punctuation we have first $xx + 5x = 98$ $xx + bx = d$
 2^{dly}, $xx + 58x = 9874$
 3^{dly}, $xx + 587x = 987459$

Also $b = 5$, next $b = 58$, lastly, $b = 587$.
 Again, $d = 98$, next $d = 9874$, then $d = 987459$. And if further prosecuted, add Ciphers at pleasure according to the preceding Rules.

$x = \frac{d - pp - bp}{2p + b} + p$, Theorem 1st:
 Or $x = \frac{d - p - bxp}{2p + b} + p$, Theor. 2^d.

An Operation according to the first Theorem.

$\begin{array}{r} 8 = p^{1st} \\ \underline{98 = d} \\ -64 \\ \hline -40 \\ \hline -104 \\ \hline 21 \overline{) -6.0} \begin{matrix} (-.2 \\ +8 \end{matrix} \\ \underline{78 = p^{2d}} \\ \hline 78, i = 6084 = pp \\ \underline{4524 = bp} \\ -10608 \\ \hline 9174 \\ \hline 156 \overline{) -734} \begin{matrix} (-3.4 \\ +78 \end{matrix} \\ \underline{746 = p^{3d} *} \end{array}$	$\begin{array}{r} * .746 \overline{) i} = 556516 \\ \underline{437902} \\ -994418 \\ \hline 987459 \\ \hline 1492 \overline{) -6459} \begin{matrix} (-3.34 \\ +746.00 \end{matrix} \\ \underline{742.66 = p^{4th}} \\ \hline 742.66 \overline{) i} = 551543.8756 \\ \underline{435941.42} \\ -987485.2256 \\ \hline 487459 \\ \hline 267282 \overline{) -26.2456} \begin{matrix} (-.012689 \\ +742.66 \end{matrix} \\ \underline{742.647311 = x \text{ fought.}} \end{array}$	
--------------------------------------------------------------------------------------------------------------------------------------------------------------------------------------------------------------------------------------------------------------------------------------------------------------------------------------------------------------------------------------------	-------------------------------------------------------------------------------------------------------------------------------------------------------------------------------------------------------------------------------------------------------------------------------------------------------------------------------------------------------------------------------------------------------------------------------------------------------------------------------	--

II. EXAMPLE.

PUT $xxx - 2x = 5$, or $xxx - bx = c$.

Here's no need of any Punctations in this Example.

$\begin{array}{r} 2 = p^{1st} \\ \underline{5 = c} \\ 4 \\ \hline 9 \\ \hline -8 = p^2 \\ \hline 18 \overline{) 1.0} \begin{matrix} (.1 \\ +2 \end{matrix} \\ \underline{2.1 = p^{2d}} \\ \hline 5 = 0 \\ \underline{4.2} \\ \hline 4.2 \\ \hline -9.261 = p^3 \\ \hline 11.23 \overline{) -061} \begin{matrix} (-.0054 \\ +2.1 \end{matrix} \\ \underline{2.0946 = p^{3d} *} \end{array}$	$\begin{array}{r} * 5 = c \\ \underline{4.1892} \\ 9.1892 = bp + c \\ \underline{-9.18741550936 = p^3} \\ \hline 11.16205 \overline{) -000541550936} \begin{matrix} (-.000048517 \\ +2.0946 \end{matrix} \\ \underline{2.094551483 = x, \text{ fought.}} \end{array}$	<p style="text-align: right;">Theorem $x = \frac{c + bp - p^3}{3pp - b} + p$</p>
--------------------------------------------------------------------------------------------------------------------------------------------------------------------------------------------------------------------------------------------------------------------------------------------------------------------------------------------------------------------------------------------	-----------------------------------------------------------------------------------------------------------------------------------------------------------------------------------------------------------------------------------------------------------------------	---------------------------------------------------------------------------------------------

Of Infinite Approximations.

III. EXAMPLE.

$$xxx + 74xx + 8729x = 560783$$

$$xxx + bxx + cx = d$$

- (1) $x^2 + 7x + 8729x = 560783$ (2) $x^2 + 74x^2 + 8729x = 560783$
 (1) $b=7$ (2) $b=74$ 1. Theor. $x = \frac{d - p^2 - bp^2 - cp}{c + 3p^2 + 2bp} + p$
 (1) $c=87$ (2) $c=8729$ 2. Theor. $x = \frac{d - p^2 - bpx}{c + 3p + 2bpx} + p$
 (1) $d=570$ (2) $d=560783$

An Operation according to the second Theorem.

$\begin{array}{r} 4 = p^2 \\ 116 = pp \\ 128 = pp \\ 187 = cp \\ -131 \text{ Total} \\ 4 = p \\ -524 \\ 560 = d \\ \hline 191 \text{) } 36 \text{ (} \\ \quad +4 = p^2 \\ \quad -4 = p^2 \end{array}$	$\begin{array}{r} * 41^2 = 11681 = pp \\ \quad -13034 = bp \\ \quad \quad 18729 = c \\ \quad -13444 \text{ Total} \\ \quad \quad 41 = p \\ \quad \quad 13444 \\ \quad \quad 53776 \\ \quad \quad 551204 \\ \quad \quad 560783 = d \\ \hline 19140 \text{) } +9579 \text{ (} \\ \quad \quad +41 = p^2 \\ \quad \quad -41 = p^2 \end{array}$	$\begin{array}{r} 41.48^2 = 11720.5904 = pp \\ \quad -13069.52 = bp \\ \quad \quad -18729 = c \\ \quad -13519.1104 \\ \quad \quad 41.48 = p \\ \quad \quad 13444 \\ \quad \quad 560772.699392 \\ \quad \quad 560783 = d \\ \hline A \quad 10.300608 \end{array}$
---------------------------------------------------------------------------------------------------------------------------------------------------------------------------------------------------------	----------------------------------------------------------------------------------------------------------------------------------------------------------------------------------------------------------------------------------------------------------------------------------------------------------------------------------------------	------------------------------------------------------------------------------------------------------------------------------------------------------------------------------------------------------------------------------------------------------------------

A 20030) 10.300608 (.000514
 $41.48 = p^2$
 $41.480514 = x \text{ sought.}$

IV. EXAMPLE.

$$-xxxxx + 7xxxx + 20xxx + 155xx = 10000$$

$$\text{Or, } xxxxx + bxxxx + cxxx + dxx = f$$

$\begin{array}{r} -5 = p^2 \\ -3125 = p^3 \\ -2500 = cp^2 \\ -4375 = bp^2 \\ -3875 = dp^2 \\ -13857 \\ 10000 = f \\ -9765 \text{) } -3875 \text{ (} \\ \quad \quad -5 = p^2 \\ \quad \quad -46 = p^2 \end{array}$	<p style="text-align: right;">Theor. $x = \frac{f - p^3 - cp^2 - bp^2 - dp^2}{-4bp^2 - 2dp - 5p^2 - 3cpp} + p$</p> $\begin{array}{r} * -2059.62976 = p^3 \\ -1946.72 = cp^2 \\ -3134.2192 = bp^2 \\ -3279.8 = dp^2 \\ -10420.36896 \\ +10000 \\ \hline -7659 \text{) } -420.36896 \text{ (} \\ \quad \quad -2725.408 = 4bp^2 \\ \quad \quad -1426.000 = 2dp \\ \quad \quad 2238.728 = 5p^2 \\ \quad \quad -1269.600 = 3cpp \\ \quad \quad -7639.736 \text{ Divisor.} \end{array}$
---------------------------------------------------------------------------------------------------------------------------------------------------------------------------------------------------------------------	------------------------------------------------------------------------------------------------------------------------------------------------------------------------------------------------------------------------------------------------------------------------------------------------------------------------------------------------------------------------------------------------------------------------------------------------------------------------------------------------

V. EX-

Of Infinite Approximations.

V. E X A M P L E.

LET this Equation be propos'd for the Septification of an Angle.

$$-x^7 + cx^5 - dx^3 + bx = q$$

Or, $-x^7 + 7x^5 + 14x^3 + 7x = 1.5$

$$\begin{array}{r} 2 = p^1 \\ \hline + 7.056090 = 5cp^4 + b \\ - 1.680448 = -7p^5 - 3dp^3 \\ \hline 5.375552 \dots \end{array}$$

Theor. $x = \frac{q+p^4+dp^3-cp^5-bp}{5cp^4+b-7p^5-3dpp} + p$

$$\begin{array}{r} + 1.6120128 = q + p^4 + dp^3 \\ - 1.4022400 = -cp^5 - bp \\ \hline .2097728 \dots \end{array}$$

$23 = p^2$

$$\begin{array}{r} 23 = p^2 \\ \hline + 7.09794435 = 5cp^4 + b \\ - 2.22283625 = -7p^5 - 3dp^3 \\ \hline 4.8751081 \dots \end{array}$$

$$\begin{array}{r} + 1.67037204825447 = q + p^4 + dp^3 \\ - 1.6149054401 \dots = -cp^5 - bp \\ \hline + .05586660815447 \dots \end{array}$$

$2415 = p^3$

$$\begin{array}{r} 2415 = p^3 \\ \hline 7.11905196957719 + 1.69723543656325544455 \\ - 2.45092317574650 - 1.69625021013057815625 \\ \hline 4.66812879383069 + .00098522643267728825 \end{array}$$

x sought = $.24171105 = p^4$

When the Powers arise very high, as in this Example, they are most convenient-ly manag'd by Logarithms.

To shew the Universality of this Method, and that there's no absolute necessity of Punctations, or taking a Quantity near the Truth, let there be taken a Quantity never so distant from Truth, it will at a few Operations converge to it; which is a great Convenience above all other Methods, in which if you be once out, you must begin again; but in this an Error is but a new Trial, and you are never out of the way, for if you prosecute that Error, you will find the Truth, and there is no need of considering the Occasion of it, further than as a Caution for the next Operation. One Example will abundantly evince this.

Let there be propos'd $xx + bx = d$ Begin as far of Truth as you please.

Or, $xx + 5x = 646$ Suppose $p = 1$.

$$\begin{array}{r} 1 = p^1 \\ \hline 646 \\ + 1 \\ \hline 7) 647 \quad (92 = p^2 \\ \underline{63} \\ 17 \quad 92 \\ \underline{184} \\ 828 \\ + 846 \\ \underline{646} \\ 189) 9110 \quad (48 = p^3 \\ \underline{756} \\ 1550 \\ \underline{384} \\ 192 \\ \underline{2304} \\ 646 \\ 101) 2950 \quad (29 = p^4 \\ \underline{202} \\ 930 \end{array}$$

Theor. $x = \frac{d-pp}{2p+b} + p$
or by Red. $x = \frac{d+pp}{2p+b}$

$$\begin{array}{r} 29 = p^4 \\ \hline 29 \\ \underline{261} \\ 58 \\ \underline{841} \\ 646 \\ 63) 2487 \quad (23 = p^5 \\ \underline{126} \\ 227 \\ \underline{69} \\ 46 \\ \underline{529} \\ 646 \\ 51) 1175 \quad (23.03 = p^{5.1} = x \text{ sought.} \\ \underline{102} \\ 155 \\ \underline{153} \\ 200 \end{array}$$

These